

# Industrial 14" CRT Monitors

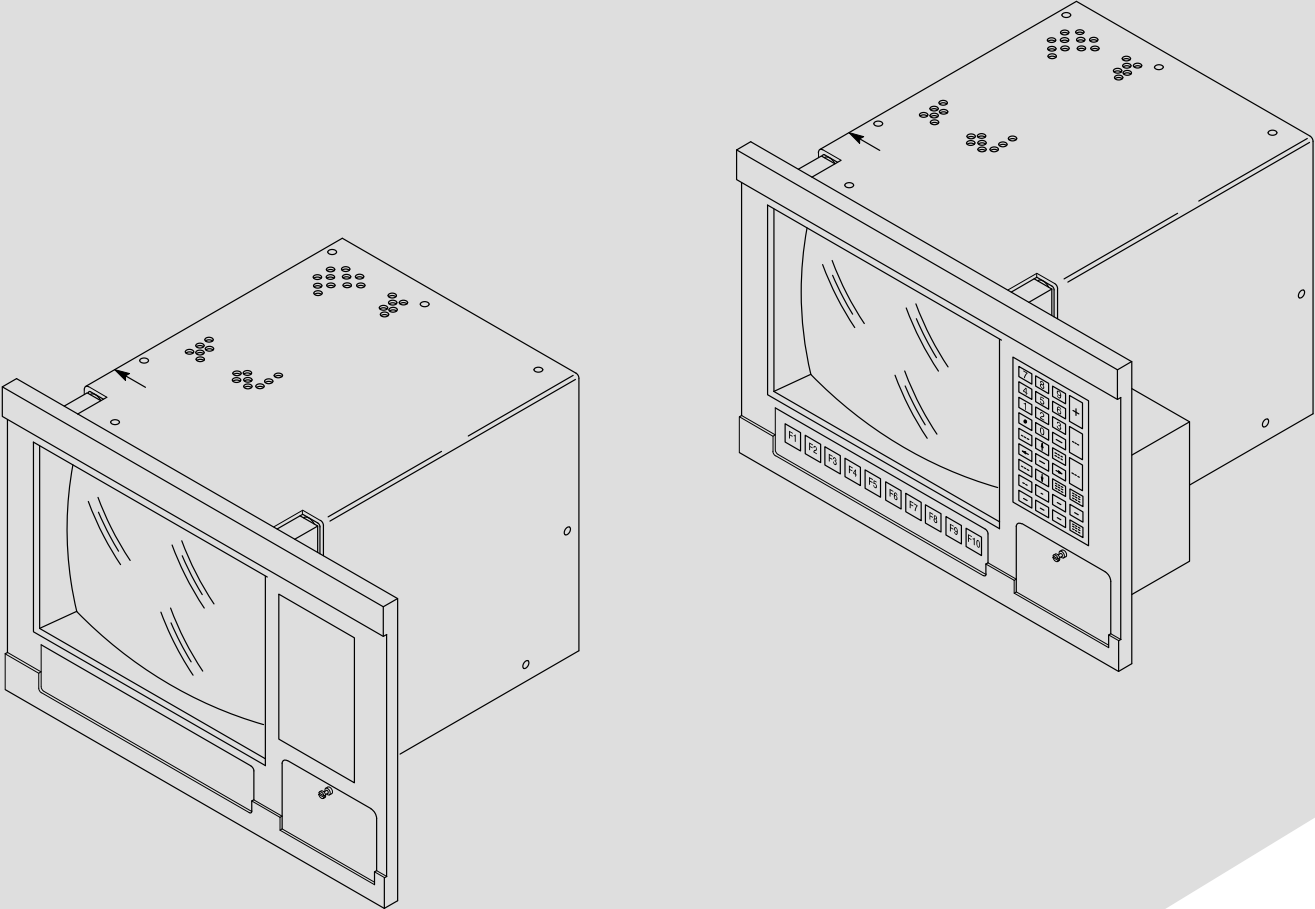

(Bulletin Number 6156)

## *Product Data and Installation Instructions*



# Table of Contents

Description	3
Dimensions	4
Installation Instructions	6
Connecting AC Power	8
Video Cables	10
The Keypad Option	11
Keyboard Extender Cables	13
The Touchscreen Option	13
Connecting to a Computer	14
Controls and Indicators	17
Maintenance	19
Troubleshooting	21
Specifications	22

## Important User Information

Solid state equipment has operational characteristics differing from those of electromechanical equipment. "Safety Guidelines for the Application, Installation and Maintenance of Solid State Controls" (Publication SGI-1.1) describes some important differences between solid state equipment and hard-wired electromechanical devices. Because of this difference, and because of the wide variety of uses for solid state equipment, all persons responsible for applying this equipment must satisfy themselves that each intended application of this equipment is acceptable.

In no event will the Allen-Bradley Company be responsible or liable for indirect or consequential damages resulting from the use or application of this equipment.

The examples and diagrams in this manual are included solely for illustrative purposes. Because of the many variables and requirements associated with any particular installation, the Allen-Bradley Company cannot assume responsibility or liability for actual use based on the examples and diagrams.

No patent liability is assumed by Allen-Bradley Company with respect to use of information, circuits, equipment, or software described in this manual.

Reproduction of the contents of this manual, in whole or in part, without written permission of the Allen-Bradley Company is prohibited.

Throughout this manual we use notes to make you aware of safety considerations.



**ATTENTION:** Identifies information about practices or circumstances that can lead to personal injury or death, property damage, or economic loss.

**Important:** Identifies information that is especially important for successful application and understanding of the product.

---

## Industrial 14" CRT Monitors

### Description

Bulletin 6156 Industrial 14 in. CRT Monitors are general purpose monitors suitable for a wide range of industrial computing applications.

### Package Contents

The Bulletin 6156 Industrial Monitor is shipped with the following items:

- 6156 Industrial 14 in. Color CRT Monitor with configurable options for keypads, touchscreen, and video interface  
Monitors without the touchscreen option have a polycarbonate screen protector.
- panel mounting hardware (package of 20 10–32 lock nuts with flat washers)
- 1.8 m (6 ft) AC power cord (optional)
- video cable (optional)
- keyboard cable (optional)
- *Industrial 14" CRT Monitors Product Data & Installation Instructions* (Publication 6156-2.0).

An Industrial Monitor with a touchscreen option is shipped with these additional items:

- supporting software and manuals
- RS-232 serial cable (optional)

# Dimensions

**Figure 1**  
**Bulletin 6156 Industrial Monitor (With Keypads)**  
**Physical Dimensions**

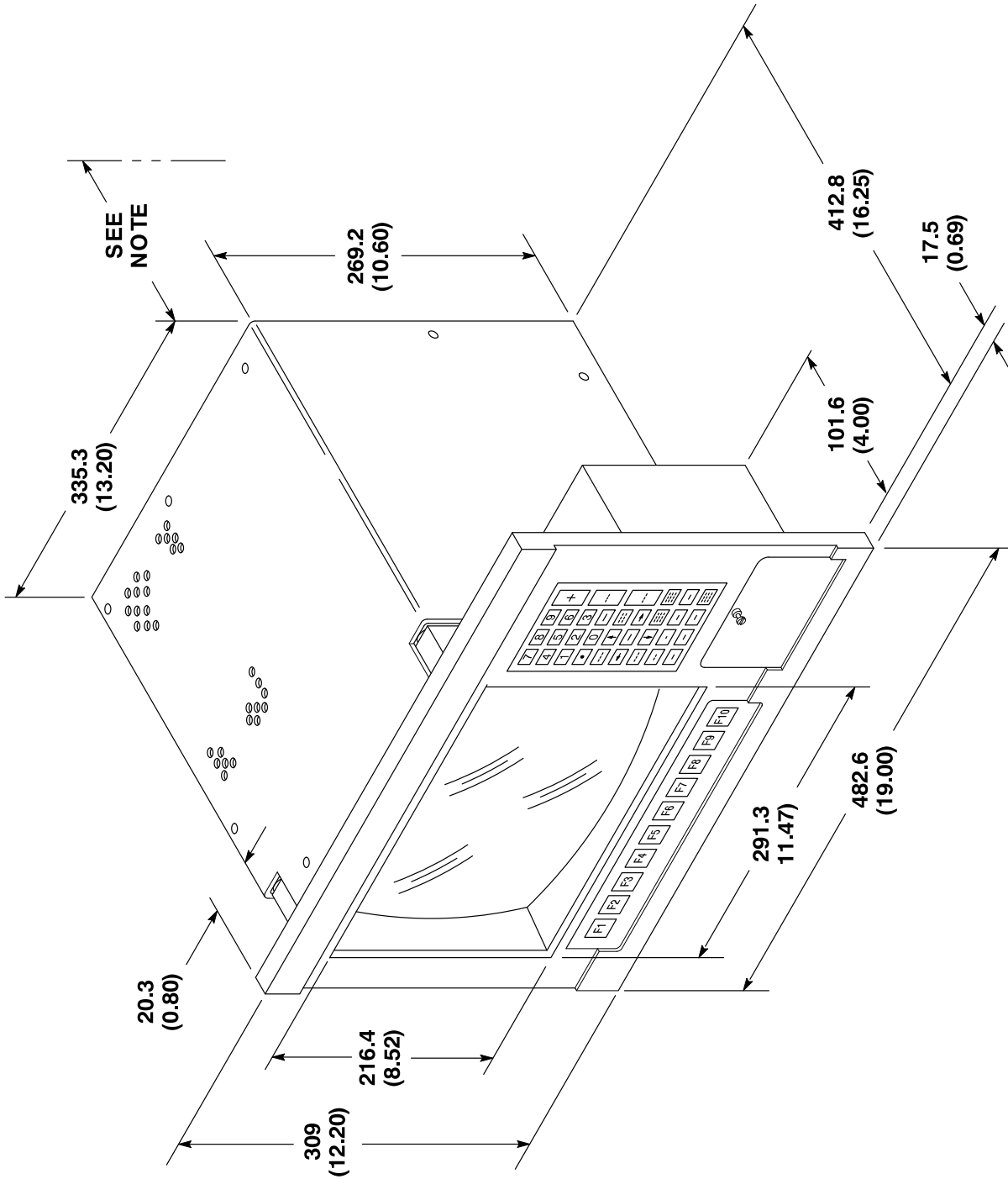

**Note:** Be sure to allow at least 76.2 mm (3.0 in.) depth clearance for cable connections and air flow.

130680

**Figure 2**  
**Bulletin 6156 Industrial Monitor (Without Keypads) Physical Dimensions**

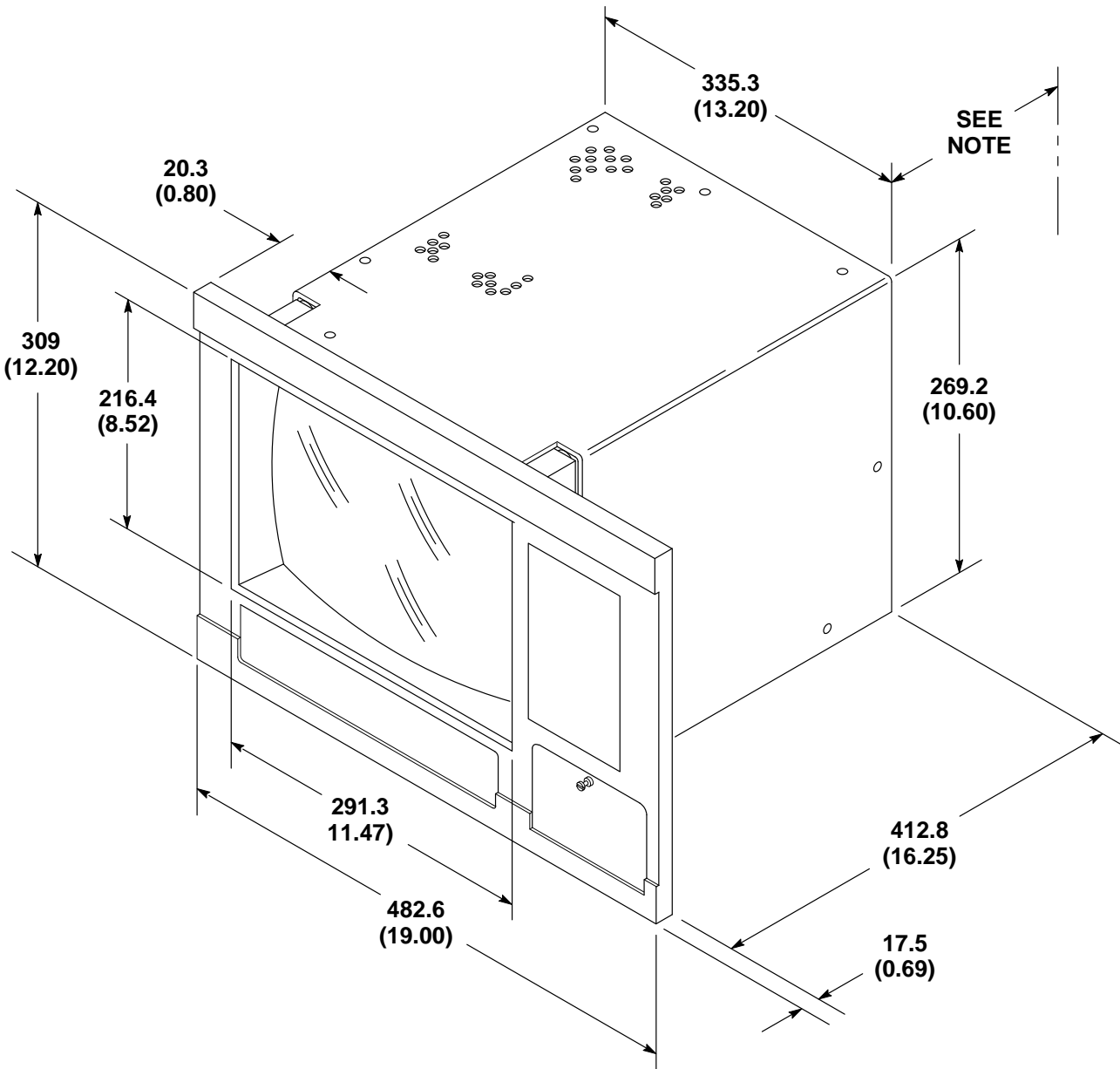

**Note:** Be sure to allow at least 76.2 mm (3.0 in.) depth clearance for cable connections and air flow.

130681

## Installation Instructions

### Environmental Considerations

The 6156 Industrial Monitor requires a minimum free air space of 76.2 mm (3 in.) behind and 50.8 mm (2 in.) above and below for proper cooling. Allen-Bradley Industrial Monitors have been designed to function without cooling fans. Therefore, maintenance of fan filters and access to them need not be a concern.

Strong magnetic fields near the front of the monitor outside the enclosure could potentially distort the image over time. This type of image distortion generally disappears after degaussing occurs. Allen-Bradley Industrial Monitors automatically degauss each time AC power is applied, or when the degauss button is pressed.

**Note:** The internal degauss will not prevent color impurities caused by local magnetic fields. Make certain the Industrial Monitor's enclosure is free of residual magnetism.

### Panel Mounting

The panel on which you will mount the Industrial Monitor should be at least 14 gauge to insure a NEMA 4 seal and proper support for the unit. The mounting studs attached to the rear of the monitor bezel will accommodate this minimum thickness panel and panels up to 6.35 mm (0.25 in.) thick.

#### **To install the Bulletin 6156 Industrial Monitor:**

1. Confirm that the shipping carton contains a package of 20 10-32 lock nuts and 20 flat washers. You will need 14 nuts and washers for installation.
2. Refer to the physical dimension drawings (Figures 1 and 2, pages 4 and 5) and confirm that there is adequate space behind the panel where the unit is to be situated. Remember to allow extra space for air circulation.
3. Refer to the panel cutout drawing (Figure 3 Page 8) for dimensions of the panel cutout and mounting hole locations. Cut and drill the panel.
4. Carefully remove the monitor from its packaging. Avoid damaging the monitor gasket.

**Tip:** It will be easier to install the monitor if you support it with a shelf or other support adjusted to the appropriate height.

- 
5. Insert the monitor in the panel cutout from the front of the panel. Be careful not to damage the threaded mounting studs as you position the monitor.
  6. Secure the unit with the locknuts and washers provided. Tighten evenly to 25 inch-pounds of torque.

**Important:** To assure a proper seal, be sure to install a washer and nut on each of the 14 mounting studs.



**ATTENTION:** Mounting nuts must be tightened to a torque of 25 inch-pounds to provide panel seal and avoid potential damage to the Bulletin 6156 Industrial Monitor. Allen-Bradley assumes no responsibility for water or chemical damage to the Bulletin 6156 Industrial Monitor or other equipment within the enclosure due to improper installation.

---

7. Remove the protective adhesive sheet from the screen of the Industrial Monitor. The sheet is designed to prevent scratching of the polycarbonate screen protector or the optional touchscreen during shipping and installation. It should be removed before use.

Figure 3  
Bulletin 6156 Panel Cutout Dimensions

TOP

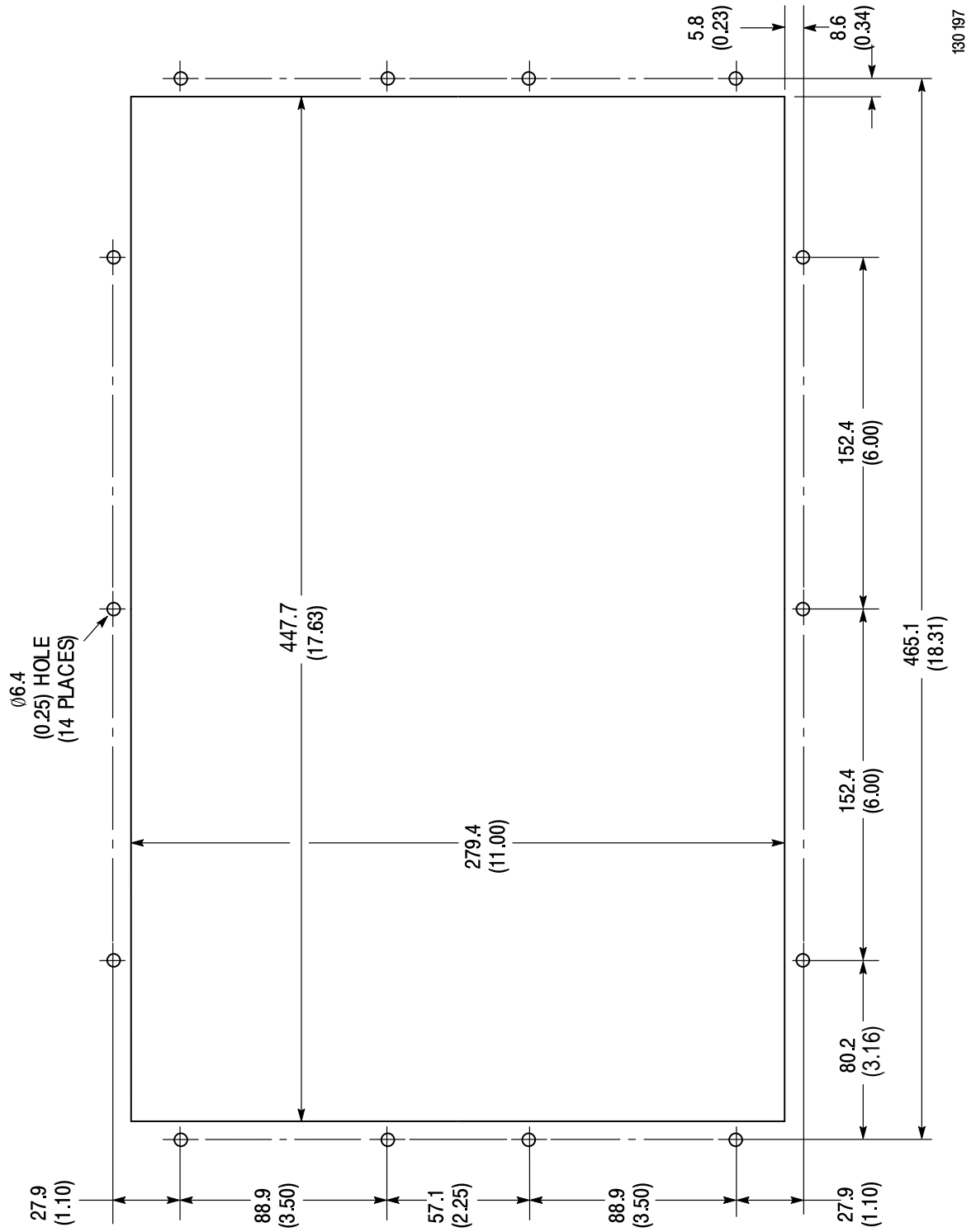



## Connecting AC Power

The Bulletin 6156 Industrial Monitor requires a single phase power supply providing 100 to 250V AC at 50 to 60 Hz. Power must be available at a grounded three-pin outlet located nearby. Whenever possible, connect the monitor to the same AC source that supplies the computer.

To connect AC power to the monitor:

1. Turn off the main switch or breaker.
2. Use the GND point on the rear panel of the monitor to establish a chassis to earth ground connection. Secure one end of a ground strap to the GND point. Connect the other end of the ground strap to a good earth ground.

The ground terminals are M5 screws.



**ATTENTION:** Chassis ground must be connected for safe operation of the monitor. The AC receptacle on the monitor is a 3-wire type with chassis ground pin, and the mating AC cord supplied is a 3-wire type, designed for connection to a grounded 3-pin AC outlet. However a properly grounded AC outlet is not always available, and grounding using a 3-wire cord can easily be defeated. If you fail to ground the monitor properly, the setup may result in personal injury from electrical shock or damage to equipment.

---

3. Connect the socket end of the AC power cord to the mating connector on the rear panel of the monitor. Position the power cord retaining clip attached to the rear panel connector over the cord's socket to secure it in place.
4. Connect the plug end of the AC power cord to the mains outlet.
5. Restore AC power to the outlet.

## Product Options

The Bulletin 6156 Industrial 14 in. CRT Monitor can be configured with the following options.

- VGA or BNC video cables
- keypads
- external keyboard connectors
- touchscreen

## Video Cables

The Bulletin 6156 Industrial Monitor can be configured with various industrial grade video cables. The standard HD15 cable is equipped with a conventional HD15 connector at each end.

**Figure 4**  
Standard Video Cable

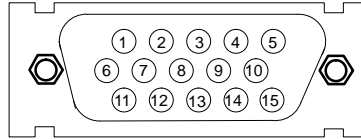

View looking into the Pin End of the  
**Male** connector

HD15

**Table A**  
Standard Video Cable Construction

Monitor HD15	Signal Description	Computer HD15
2	Green Video	2
7	Green Video Ground	7
1	Red Video	1
6	Red Video Ground	6
3	Blue Video	3
8	Blue Video Ground	8
5	Composite Sync	5 (Not Used)
11 (Floating)	ID0	11
12 (Floating)	ID1	12
4 (Gnd)	ID2	4
9	Not Connected	9
14	Vertical Sync	14
10	Sync Ground	10
15	Control	15 (Not Used)
13	Horizontal Sync	13

In addition to the standard video cable, special low noise coaxial video cables are available in various lengths. They are equipped with a DB-13C3 connector at the monitor end and a standard HD15 connector at the computer end.

**Table B  
Coaxial Cable Construction**

Monitor DB-13C3	Signal Description	Computer HD15
A1 Center Pin	Green Video	2
A1 Outer	Green Video Ground	7
A2 Center Pin	Red Video	1
A2 Outer	Red Video Ground	6
A3 Center Pin	Blue Video	3
A3 Outer	Blue Video Ground	8
1, 2, 3, 6, 7, 8	Not Connected	4, 9, 11, 12, 15
4	Vertical Sync	14
5	Horizontal Sync Ground	10
9	Vertical Sync Ground	5
10	Horizontal Sync	13

Another low noise video interface is the Differential BNC Input connectors option which accepts red, green and blue video signals (RS-343 analog signaling) and a separate composite sync signal from the video source. BNC to BNC cable options are available.

**The Keypad Option**

The keypad option provides a 10-key function keypad and a 33-key pad with numeric keys, cursor keys, and modifier keys. The keypad keys function just like the equivalent keys on standard IBM AT keyboards.

**Figure 5  
The Function Key Pad**



**Table C  
Keypad Scan Code Values**

Keypad Legend	Scan Code (Hex)
F1	3B
F2	3C
F3	3D
F4	3E
F5	3F
F6	40
F7	41
F8	42
F9	43
F10	44

**Figure 6**  
**Numeric Keypad**

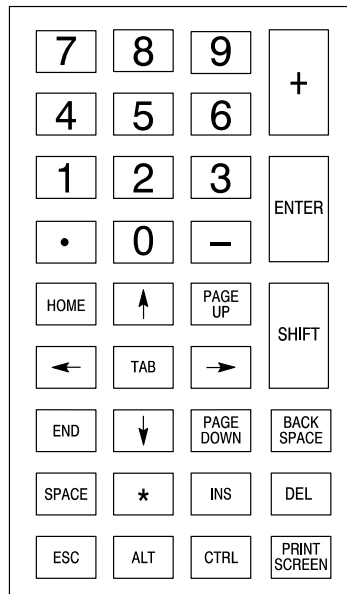
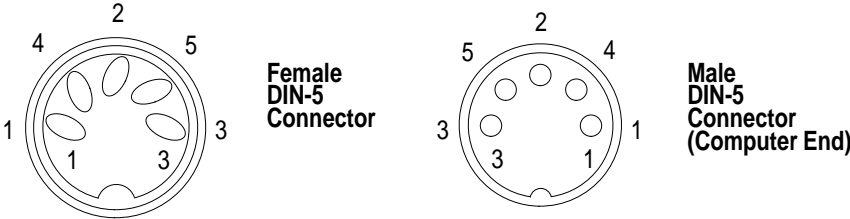

**Table D**  
**Numeric Keypad Functions and Scan Codes**

Keypad Legend	Corresponding AT Key	Scan Code (Hex)	Keypad Legend	Corresponding AT Key	Scan Code (Hex)
7	Number Pad 7 / Home	47	TAB	Main Pad Tab	0F
8	Number Pad 8 / Up Arrow	48	ENTER	Main Pad Enter	1C
9	Number Pad 9 / Pg Up	49	SPACE	Main Pad Space Bar	20
-	Number Pad -	4A	SHIFT	Main Pad Left Shift	2A
4	Number Pad 4 / Left Arrow	4B	CTRL	Main Pad Left Control	1D
5	Number Pad 5	4C	ALT	Main Pad Left Alt	38
6	Number Pad 6 / Right Arrow	4D	HOME	Home	E0, 47
+	Number Pad +	4E	↑	Up Arrow	E0, 48
1	Number Pad 1 / End	4F	PAGE UP	Page Up	E0, 49
2	Number Pad 2 / Dn Arrow	50	←	Left Arrow	E0, 4B
3	Number Pad 3 / Pg Dn	51	→	Right Arrow	E0, 4D
0	Number Pad 0 / Ins	52	END	End	E0, 4F
.	Number Pad . / Del	53	↓	Down Arrow	E0, 50
*	Number Pad *	37	PAGE DOWN	Page Down	E0, 51
ESC	Main Pad Escape	01	INS	Insert	E0, 52
BACK SPACE	Main Pad Back Space	0E	DEL	Delete	E0, 53
			PRINT SCREEN	Print Screen	E0, 2A, E0, 37

### Keyboard Extender Cables

For units configured with the keypad option, a keyboard extender cable is available in various lengths.



**Table E**  
Standard Keyboard Cable Construction

Female DIN-5	Signal Description	Male DIN-5
1	Keyboard Clock	1
2	Keyboard Data	2
3	Not Used	3
4	0 Volts	4
5	+5V	5

### The Touchscreen Option

The Touchscreen option provides a high resolution resistive or capacitive touchscreen system. Software drivers provided with the touchscreen option allow you to use the touchscreen as a pointing device with many popular DOS and Windows-based industrial applications. Refer to the touchscreen documentation for information on installing and using the touchscreen.

### Touchscreen Serial Cables

For units configured with the touchscreen option, a touchscreen serial cable is available in various lengths and with either a 9-pin or 25-pin communications port D-shell.

**Table F**  
Allen-Bradley Touchscreen Serial (RS-232) Cable Construction

9-pin D	Signal Description	9-pin D
1	Not Connected	1
2	Transmit Data	2
3	Receive Data	3
4	Data Terminal Ready (DTR)	4
5	Common Signal Return	5
6	Not Connected	6
7	Request To Send (RTS)	7
8	Clear To Send (CTS)	8
9	Not Connected	9

Cable shield is grounded through the connector shells

## Connecting to a Computer

Connect the Industrial Monitor to a computer with a video cable. A keyboard extender cable is required for monitors equipped with the keypad option. A touchscreen serial cable is required for monitors equipped with the touchscreen option. To connect your monitor to a computer:

1. Plan the route for the cables through the enclosure and confirm that the cables you have ordered are long enough for the routing you have chosen.

**Figure 7**  
Rear Panel of Monitor

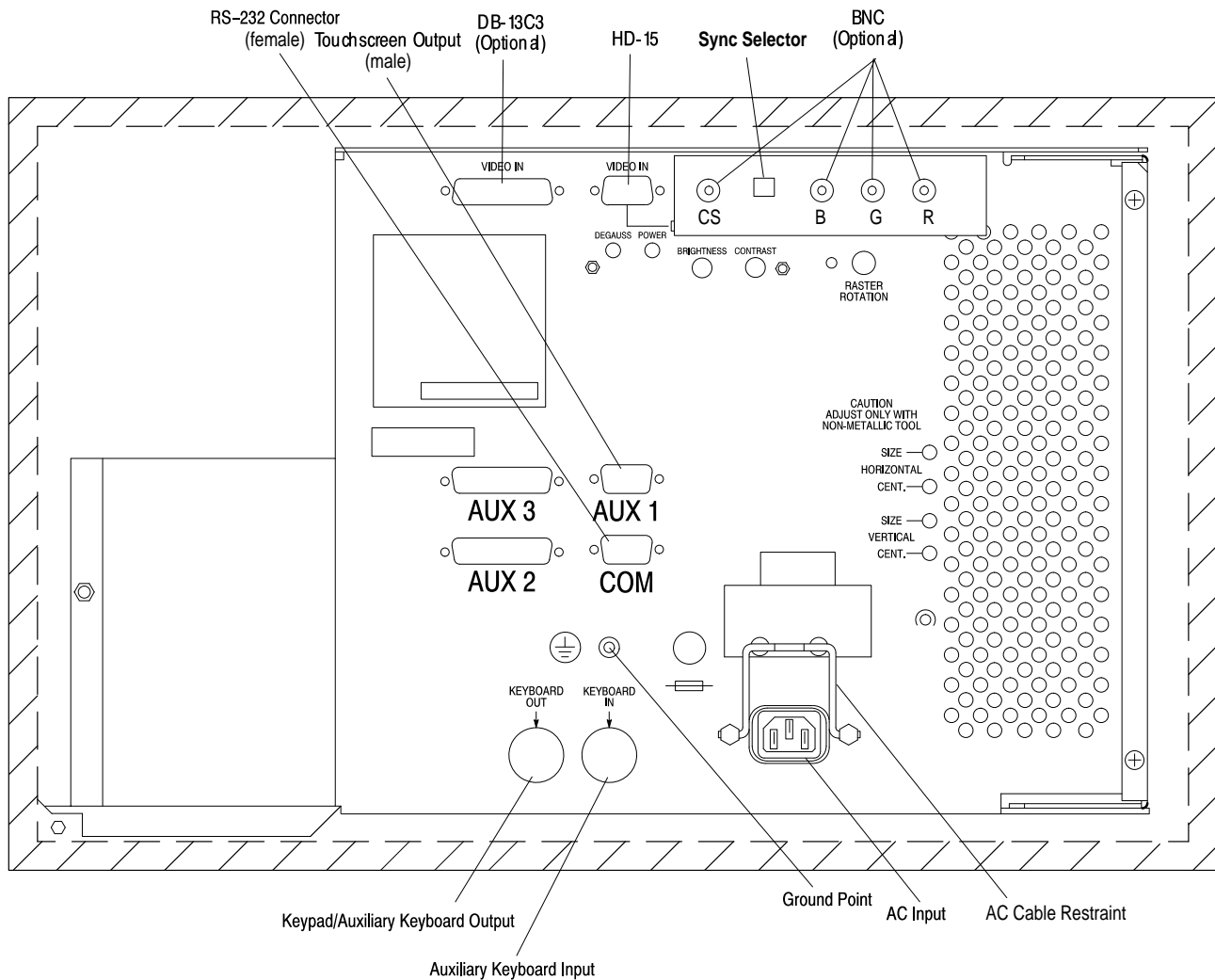

2. If you are using a standard HD15 video cable with the Industrial Monitor, connect either end of the cable to the 15-pin video input connector. See the rear panel drawing (Figure 7) to locate the connector. Tighten the captive screws on the cable connector to secure it.

Or

If you are using the optional DB-13C3 video interface, connect the large end of the video cable to the large video input connector. Tighten the captive screws on the cable connector to secure it.

Or

If you are using the optional 4 BNC video interface, connect the ends of the BNC video cable to the red, green, blue and composite sync input connectors.

**Note:** The 6156 Industrial Monitor has one HD15 video connector and can be optionally equipped with two different video connectors. The conventional HD15 connector and the larger DB-13C3 connector are wired in parallel and constitute a single interface, or the HD15 and the Differential BNC inputs are wired in parallel and constitute a single interface.

**Note:** The DB-13C3 type connector supports special low noise cables. These video cables are recommended especially for high noise environments and for longer cable runs. The computer end of all standard HD15 and optional DB-13C3 cables include a standard HD15 connector. The BNC cables available are 4 BNC to 4 BNC connections.

3. For monitors configured with the keypad option and keypad extender cable, use the 5-pin DIN keyboard cable. Connect the female end to the monitor's keypad/auxiliary keyboard output connector.

**Note:** When this cable is connected to the computer keyboard connector, an IBM AT keyboard may be connected to the front panel 5-pin DIN connector or to the rear panel Auxiliary Keyboard input connector. Only one auxiliary keyboard input port can be used at any time.

4. You may use a standard RS-232 cable to support a mouse or other device connected via the monitor's RS-232 connector (located behind the front panel door). Connect one end of the RS-232 cable to the connector labeled "COM" on the rear panel of the monitor. A cable with captive screws should be used and they should be tightened to secure it.

5. For monitors configured with the touchscreen option, connect one end of the serial touchscreen cable to the connector labeled "AUX1" on the rear panel of the monitor. Tighten the captive screws to secure it.
6. Route and secure the cables. In cases where the cable crosses a door hinge, be sure to leave enough excess cable for a loose fit in all door positions. Bulletin 6156 Industrial Monitor cables are designed to be flexible, so routing across a hinge should not result in application failure. The minimum recommended bend radius for a video cable is 38 mm (1.5 in.).
7. Connect the standard 15-pin connector end of the video cable to the computer's video output connector. Tighten the captive screws on the cable connector to secure it.
8. Connect the keyboard cable to the keyboard input connector on the computer.
9. Connect the touchscreen cable free end to an appropriate RS-232 communications port on the computer. Tighten the captive screws on the cable connector to secure it.
10. If you are installing an RS-232 serial communications cable, connect the free end to an appropriate RS-232 port on the computer.
11. Coil and secure any extra cable length in a convenient location.



### Controls & Indicators

The following is a summary of the controls and indicators on the Bulletin 6156 Industrial Monitor.

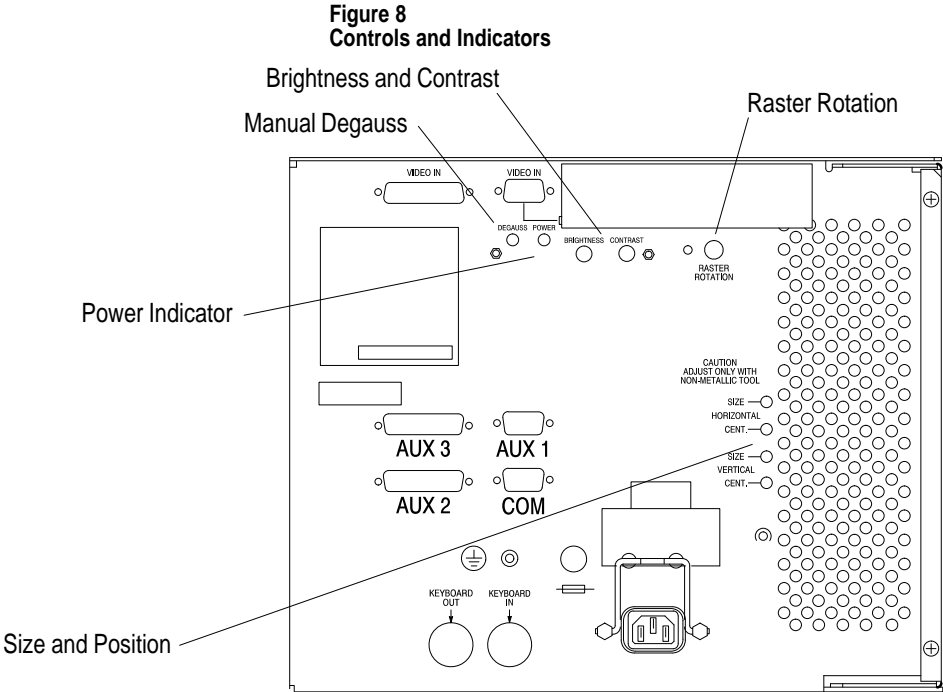

#### Power Indicator

The presence of AC power at the Bulletin 6156 Industrial Monitor is indicated by a green LED on the rear panel.

#### Contrast, Brightness, Size and Position Controls

The Bulletin 6156 Industrial Monitor is equipped with adjustable **contrast** and **brightness** controls. These controls are located on the rear panel of the unit.

To obtain the best display, first set the contrast control for comfortable viewing under lighting conditions that match those in which the monitor will be used. Adjust the brightness control to increase or decrease the video image's intensity as required.

The monitor is factory preset and normally requires no manual adjustment for vertical or horizontal alignment. However, four screwdriver adjustable **size and position** controls are provided to permit adjustment if it should ever become necessary. Adjust controls using a non-metallic insulated 1/8" (3mm) flat screwdriver passed through the hole(s) of the rear cover. With a suitable full screen image on display, adjust the Vertical Size for a height of 7.5" and the Horizontal Size for a width of 10.0". Adjust Vertical and Horizontal Position controls as necessary to center the image on the screen.

### Degauss

The monitor is equipped with an automatic degaussing system to remove residual magnetism from the CRT's shadow mask at power-up. Degaussing helps keep the screen free of any color impurities which might otherwise result from magnetism picked up by the shadow mask from the earth's magnetic field when the monitor is moved.

In addition, a **degauss** push button is provided on the rear panel. This manual control can be used if color impurities appear on the screen while the monitor is in operation.

**Note:** The internal degauss will not prevent color impurities caused by local magnetic fields. Make certain the monitor's enclosure is free of residual magnetism.



**Tip:** For best results, perform a manual degauss only after allowing at least 15 minutes to pass following power-up or a previous manual degauss.

### Raster Rotation

A **raster rotation** allows for corrections to any display misalignment which might be present as a result of interaction between the monitor and an external, low level uniform magnetic field, such as the earth's magnetic field.

All CRT displays are affected by the earth's magnetic field and by similar low level uniform fields. Generally, the effects of such a field on the display vary with the display's spatial orientation relative to the field lines. For, example, when the Bulletin 6156 Industrial Monitor's screen is facing West, the effects of the earth's field are minimal, but when the screen is rotated toward the North or South the display itself can exhibit a small amount of rotation, so that its top and bottom edges are no longer parallel to the edges of the panel.

**Note:** This effect is different from the effect of magnetism on the shadow mask, which takes the form of color impurity and is corrected by the degaussing system described previously.

Before making any adjustment, display a full screen image and check for rotation (top or bottom edge of the image out of parallel with the corresponding edge of the panel).

If adjustment is necessary,

1. Loosen the lock nut on the control shaft.
2. While observing the display (in a mirror if necessary) use a flat blade screwdriver to adjust the alignment.

**Note:** Don't forget to re-tighten the lock nut after the adjustment is made.

**Important:** The raster rotation control cannot correct for the effects of external AC fields such as those produced by large motors, generators and transformers. Such effects often take the form of display jitter. Protection against this kind of magnetic interference requires special shielding.



**ATTENTION:** Do not attempt to change any adjustments located on the monitor chassis' left side (as viewed from the front of the monitor). These adjustments are for factory trained personnel using special test and alignment equipment and should not be required to obtain a good display in the field.

---

## Maintenance

### Preparation for Shipment

If it is ever necessary to ship the monitor, first remove it from the panel in which it has been installed, then securely pack it. To remove the monitor from the panel, reverse the installation procedure that begins on page 6. Whenever possible, ship the monitor in its original container.



**ATTENTION:** Never try to ship the monitor while it is mounted in a panel. Doing so could result in damage to the panel or monitor.

---

### Fuse replacement

Bulletin 6156 Industrial Monitors are equipped with an AC line fuse, which is accessible from the rear panel. To replace the fuse:

1. Remove AC power by disconnecting the AC line cord.
2. Use a flat blade screwdriver to unscrew the cap on the fuse holder.
3. Remove the cap and fuse.
4. Replace the fuse with a 5ST Slo-Blo type rated at 2.5A, 250VAC.
5. Secure the fuse holder cap with the screwdriver.
6. Restore AC power.

### Cleaning instructions

To clean the monitor screen protector, use a 50% solution of alcohol (ethanol or isopropyl) in water on a cotton gauze pad or soft cotton cloth. Paper products may scratch the surface, and should be avoided.

**Note:** The solvent should be applied only to the cloth, and not directly to the surface to be cleaned.

## Troubleshooting

The following table can help you identify the potential cause of problems you may encounter while using the 6156 Industrial Monitor.



**ATTENTION:** When attempting to correct a problem, do not change any adjustments located on the monitor chassis' left side (as viewed from the front of the monitor). These adjustments are for factory trained personnel using special test and alignment equipment.

Symptom	Possible Cause	Procedure
No Video	No power	Check to see if rear panel LED is illuminated; if not, check power wiring; check for presence of proper voltage; check AC line fuse
	Video cable problem	Check for proper video cable installation; replace suspected faulty cable
	Brightness/Contrast controls misadjusted	Adjust brightness/contrast controls
Images distorted or off-center or Video not synced (screen rolls)	Video adapter not compatible or misconfigured	Check to insure that the graphics adapter is a VGA type and is configured to provide a display compatible with the monitor
	Monitor misadjusted	Adjust width, horizontal position, and vertical position controls
	Video cable problem	Check for proper video cable installation; replace suspected faulty cable
	Sync select switch set improperly (BNC Version only)	Set sync select switch to correct source
Color appears wrong	Video cable problem	Check for proper video cable installation; replace suspected faulty cable
	Build-up of residual magnetism	Manually degauss unit
No keypad communications	Keypad cable problem	Check for proper cable installation; replace suspected faulty cable
No touchscreen communications	Touchscreen cable problem	Check for proper cable installation; replace suspected faulty cable
Other touchscreen failures	Various	Refer to additional documentation provided with unit from touchscreen manufacture

## Specifications

<b>Display</b>	
Type	CRT, Color
CRT Size	14" Diagonal
Nominal Display Area	10.0" Horizontal x 7.5" Vertical (254mm x 191mm)
Resolution	640 x 480 to 1024 x 768, autosync
Dot Pitch	0.28mm
Luminance	40 ft-Lamberts (137 cd/m <sup>2</sup> with full screen white flood)
Horizontal Scan Rate	30 kHz to 56 kHz
Vertical Scan Rate	40 Hz to 90 Hz
Video Bandwidth	75 MHz
Video Inputs	RGB Analog, RS-343A (0.7V peak into 75 Ohms = 100% modulation)
Sync Type	Separate Horizontal and Vertical Sync Control. TTL signal levels.
Sync Polarity	Horizontal – Negative or positive Vertical – Negative or positive
<b>Controls and Indicators</b>	
	Rear panel power-on LED (green), Brightness, Contrast, Manual Degauss, Horizontal Size, Horizontal Position, Vertical Size, Vertical Position, Raster Rotation
<b>Electrical</b>	
Power Requirement	100–250VAC , 50–60 Hz, single phase
Power Consumption	120W maximum
<b>Connectors</b>	
Video Input (rear panel)	Female HD15, Female DB-13C3, or 4 BNC
Touchscreen port output (rear panel AUX1)	Male 9-pin D
RS-232 port (rear panel COM for units with keypad option only)	Female 9-pin D
Keypad / Aux keyboard output (rear panel)	Male DIN 5-pin
Aux keyboard input (rear panel for units with keypad option only)	Female DIN 5-pin
Aux keyboard input (behind front panel door, for units with keypad option only)	Female DIN 5-pin
RS-232 port (behind front panel door, for units with keypad option only)	Male 9-pin D

**Specifications (Continued)**

<b>Environmental</b>	
Operating Temperature	0°C to +50°C
Storage Temperature	-30°C to +70°C
Relative Humidity	5% to 95% (non-condensing)
Operating Shock	15g (1/2 sine, 11 msec duration)
Non-operating Shock	30g (1/2 sine, 11 msec duration)
Operating Vibration	0.01 in. p-p 5-17 Hz sine, 1.5g peak, 17-640 Hz sine
Non-operating Vibration	0.2 in. p-p 5-16 Hz sine, 2.5g peak, 16-640 Hz sine
<b>Physical</b>	
Faceplate Overall Height	12.2" (310mm)
Faceplate Overall Width	19.0" (483mm)
Overall Depth (from rear surface of front panel to back)	16.3" (414mm)
Net Weight	approx. 50lbs (23kg)
<b>Standards Compliance</b>	
RF Emissions	FCC Class A Certified
Safety (Electrical Shock, Fire)	EN60950, UL / C-UL 1950 recognized component
CE Compliance	Directives 89/336/EEC, 73/23/EEC
Enclosure	UL / C-UL 508 Listed NEMA 4, 12, 13 (when properly installed in panel)
X-ray Emissions	DHHS CFR 21.1020 compliant

IBM is a registered trademark of International Business Machines Corporation  
VGA is a trademark of International Business Machines Corporation.  
PC AT is a trademark of International Business Machines Corporation  
Microsoft is a registered trademark of Microsoft.  
Microsoft Windows is a trademark of Microsoft.



Rockwell Automation helps its customers receive a superior return on their investment by bringing together leading brands in industrial automation, creating a broad spectrum of easy-to-integrate products. These are supported by local technical resources available worldwide, a global network of system solutions providers, and the advanced technology resources of Rockwell.

## Worldwide representation.

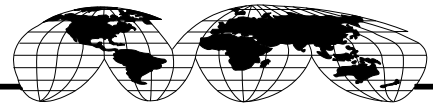

Argentina • Australia • Austria • Bahrain • Belgium • Bolivia • Brazil • Bulgaria • Canada • Chile • China, People's Republic of • Colombia • Costa Rica • Croatia • Cyprus • Czech Republic • Denmark • Dominican Republic • Ecuador • Egypt • El Salvador • Finland • France • Germany • Ghana • Greece • Guatemala • Honduras • Hong Kong • Hungary • Iceland • India • Indonesia • Iran • Ireland • Israel • Italy • Jamaica • Japan • Jordan • Korea • Kuwait • Lebanon • Macau • Malaysia • Malta • Mexico • Morocco • The Netherlands • New Zealand • Nigeria • Norway • Oman • Pakistan • Panama • Peru • Philippines • Poland • Portugal • Puerto Rico • Qatar • Romania • Russia • Saudi Arabia • Singapore • Slovakia • Slovenia • South Africa, Republic of • Spain • Sweden • Switzerland • Taiwan • Thailand • Trinidad • Tunisia • Turkey • United Arab Emirates • United Kingdom • United States • Uruguay • Venezuela

Rockwell Automation Headquarters, 1201 South Second Street, Milwaukee, WI 53204-2496 USA, Tel: (1) 414 382-2000 Fax: (1) 414 382-4444

Rockwell Automation European Headquarters, Avenue Hermann Debroux, 46, 1160 Brussels, Belgium, Tel: (32) 2 663 06 00, Fax: (32) 2 663 06 40

Rockwell Automation Asia Pacific Headquarters, 27/F Citicorp Centre, 18 Whitfield Road, Causeway Bay, Hong Kong, Tel: (852) 2887 4788, Fax: (852) 2508 1846

World Wide Web: <http://www.ab.com>