



AUTO-TRACKING WITH DIGITAL CONTROL
COLOR DISPLAY MONITOR

MODEL

HL7925K SERIES

USER'S GUIDE

For future reference, record the serial number of your display monitor in the space below:

SERIAL No.

The serial number is located on the rear cover of the set.

注 意

本品は外国為替及び外国貿易管理法に定める戦略物資（又は役務）に該当するため、輸出する場合、同法に基づく輸出（又は役務取引）許可が必要です。

CAUTION

These products or technologies are subject to Japanese and/ or COCOM strategic restrictions, and diversion contrary thereto is prohibited.

CAUTION

- The line cord and plug designed for safety is provided with this set. It is to be used with a properly grounded power receptacle to avoid possible electrical shock.
- Do not remove the back cover of the set as this can expose you to very high voltages and other hazards.

For Model HL7925K and HL7925KW Series:

WARNING

RADIO INTERFERENCE REGULATIONS STATEMENT FOR U.S.A.

This equipment has been tested and found to comply with the limits for a Class A digital device, pursuant to Part 15 of the FCC Rules. These limits are designed to provide reasonable protection against harmful interference when the equipment is operated in a commercial environment. This equipment generates, uses, and can radiate radio frequency energy and, if not installed and used in accordance with the instruction manual, may cause harmful interference to radio communications. Operation of this equipment in a residential area is likely to cause harmful interference in which case the user will be required to correct the interference at his own expense.

THIS PRODUCT HAS BEEN FCC-CERTIFIED WITH A SHIELDED
SIGNAL COAXIAL CABLE.
USE IT TO REDUCE THE POSSIBILITY OF CAUSING INTERFER-
ENCE TO RADIO, TELEVISION, AND OTHER ELECTRONIC
DEVICES.

RADIO INTERFERENCE REGULATIONS STATEMENT FOR CANADA

This digital apparatus does not exceed the Class A limits for radio noise emissions from digital apparatus set out in the Radio Interference Regulations of the Canadian Department of Communications.

CONTENTS

1. SPECIFICATION	
1.1 Rating and Specification	4
1.2 Input Signals	5
1.3 Recommended Timing Chart	6
2. INSTALLATION	
2.1 General	7
2.2 Unpacking	7
2.3 Installation Place	7
2.4 Caution before Power ON	8
2.5 Degaussing	9
2.6 Connection of Signal Cables	9
3. CONTROLS LOCATION AND DESCRIPTION	
3.1 Under normal operation	12
3.2 When adjusting the picture dimensions	16
3.3 Explanation on Channel	19
4. ADJUSTMENT	
4.1 Preparation	21
4.2 Procedure	21
4.3 What picture comes out ?	25
5. QUICK CHECK	
5.1 Monitor screen is blank	27
5.2 Monitor screen Image is too dim or bright	27
5.3 Monitor generates beep sound	28
5.4 Booming sound just after power "ON"	28
5.5 Monitor screen is not stable	28
6. CARE and MAINTENANCE	
6.1 General	29
6.2 Operation	29
6.3 Cleaning	30

1. SPECIFICATIONS

1.1 Rating and Specification

1) AC POWER VOLTAGE

MODEL	RATING
HL7925*K	AC 100 ~ 120 V
HL7925*KV	AC 220 ~ 240 V
HL7925*KW	AC 100 ~ 120 V AC 220 ~ 240 V

- 2) AC POWER FREQUENCY 50/60 Hz
- 3) POWER CONSUMPTION 150 W (typ)
- 4) INPUT SIGNAL Analog R,G,B : 0.7 Vp-p (Positive)
 VIDEO Composite sync. on Green: 0.7 Vp-p (Negative)
 SYNC. Composite ext. sync. : 1.5 ~ 5 Vp-p (Negative)
 Separate sync. (HD/VD) : 1.5 ~ 5 Vp-p (Positive/Negative)
- 5) INTERFACE BNC (Receptacle)
 a) INPUT CONNECTOR 75Ω for video and sync. signal
 b) INPUT IMPEDANCE High impedance can be selected by Impedance Select SW.
 Loop-through operation is available with T-type BNC connector.
- 6) SCANNING FREQUENCY HORIZONTAL 30 kHz ~ 78 kHz
 VERTICAL 50 Hz ~ 120 Hz
- 7) PRE-SET TIMING See the recommended timing chart specification. (page 6)
- 8) WARM UP TIME More than 30 minutes.
- 9) EFFECTIVE DISPLAY AREA 360 (W) × 270 (H) mm
- 10) BRIGHTNESS 100 nit with STD CRT, standard white window video signal.
- 11) VIDEO AMPLIFIER 50 Hz ~ 120 MHz ±3 dB Tr/Tf < 6 nsec
- 12) BLANKING TIME Horizontal 55-78 kHz < 3.2μsec
 40-55 kHz < 5.0μsec
 30-40 kHz < 6.0μsec
 Vertical < 600μsec
- 13) LINEARITY Better than 7%
 Note; H-LIN will be specified for
 $F_H = 30-37/47-52/60-64 \text{ kHz}/75 \sim 78$
- 14) RASTER DISTORTION Less than 2.0%
- 15) RASTER SIZE REGULATION Less than 0.5%
- 16) MISS CONVERGENCE Center (Within 270 mm diameter circle) -0.35 mm (Typ)
 Other area -0.5 mm (Typ)
- 17) HIGH VOLTAGE 27 kV (STD)
- 18) TEMPERATURE 0 ~ 40°C (with standard cabinet)
- 19) OUTLINE SIZE 498 (W) × 449 (H) × 534 (D) (with standard cabinet)
- 20) WEIGHT Approx. 33 kg

SPECIFICATION

1.2 Input Signals

SYNC. SIGNAL	INPUT SIGNALS		POLARITY
A COMPOSITE SYNC. SIGNAL ON GREEN VIDEO SIGNAL	RED	0.7 V _{p-p} TYP (0.35 ~ 1.4 V _{p-p} AVAILABLE)	POSITIVE
	BLUE		
	GREEN	1.0 V _{p-p} TYP (0.7 V _{p-p} VIDEO) (0.3 V _{p-p} SYNC.)	VIDEO: POSITIVE SYNC. : NEGATIVE
COMPOSITE EXT SYNC. SIGNAL	RED	0.7 V _{p-p} TYP (0.35 ~ 1.4 V _{p-p} AVAILABLE)	POSITIVE
	BLUE		
	GREEN		
	COMPOSITE SYNC.	4.0 V _{p-p} TYP (1.5 ~ 5.0 V _{p-p} AVAILABLE)	NEGATIVE
SEPARATE HORIZONTAL & VERTICAL SYNC. SIGNAL	RED	0.7 V _{p-p} TYP (0.35 ~ 1.4 V _{p-p} AVAILABLE)	POSITIVE
	BLUE		
	GREEN		
	HORIZONTAL VERTICAL SYNC.	4.0 V _{p-p} TYP (1.5 ~ 5.0 V _{p-p} AVAILABLE)	NEGATIVE / POSITIVE

SPECIFICATION

1.3 Recommended Timing Chart

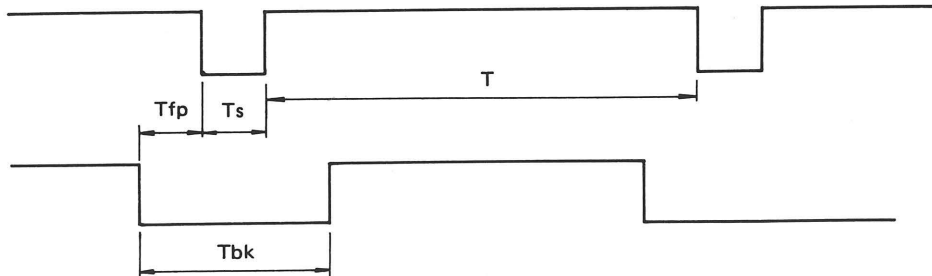

TIMING-1 (Pre-set in CH. 0)

Th	13.158 μ sec (76 kHz)
Ths	1.1 μ sec
Thfp	0.158 μ sec
Thbk	3.058 μ sec
Tv	14.29 msec (1024H)
Tvs	39.0 μ sec
Tvfp	39.0 μ sec
Tvbk	815.0 μ sec

TIMING-2 (Pre-set in CH. 0)

Th	15.788 μ sec (63.3 kHz)
Ths	1.701 μ sec
Thfp	0.407 μ sec
Thbk	3.957 μ sec
Tv	16.672 msec (1056H)
TVs	47.0 μ sec (3H)
Tvfp	47.0 μ sec (3H)
Tvbk	504.0 μ sec (32H)

TIMING-3 (Pre-set in CH. 0)

Th	20.960 μ sec (47.7kHz)
Ths	2.000 μ sec
Thfp	1.000 μ sec
Thbk	5.000 μ sec
Tv	16.667 msec (795H)
TVs	84.0 μ sec (4H)
Tvfp	63.0 μ sec (3H)
Tvbk	566.0 μ sec (27H)

TIMING-4 (Pre-set in CH. 0)

Th	26.4 μ sec (37.9kHz)
Ths	3.2 μ sec
Thfp	1.0 μ sec
Thbk	6.4 μ sec
Tv	16.58 msec (600H)
TVs	106.0 μ sec
Tvfp	26.0 μ sec
Tvbk	739.0 μ sec

TIMING-5 (Pre-set in CH. 8)

Compatible Timing for VGA 3 modes

Th	31.778 μ sec (31.5kHz)
Ths	3.813 μ sec
Thfp	0.636 μ sec
Thbk	6.356 μ sec
Tv	480 LINE (60 Hz)
TVs	16.683 msec
Tvfp	64.0 μ sec
Tvbk	318.0 μ sec
Tvbk	1430.0 μ sec

Tv	400 LINE (70 Hz)
TVs	14.268 msec
Tvfp	64.0 μ sec
Tvbk	381.0 μ sec
Tvbk	1557.0 μ sec

Tv	350 LINE (70 Hz)
TVs	14.268 msec
Tvfp	64.0 μ sec
Tvbk	1176.0 μ sec
Tvbk	3146.0 μ sec

2. INSTALLATION

2.1 General

This section explains how to install the monitor and how to verify its basic operation. The monitor is thoroughly adjusted and checked out at the factory, but it may require certain minor adjustments to adapt it to a particular display generator or other controller and to compensate for minor adjustment disturbances caused during transportation. Complete adjustment procedures and other basic checks are described in section 4, and section 5, but only selected simple procedures should be necessary for initial installation.

2.2 Unpacking

The monitor is normally packaged in a separated shipping container by MITSUBISHI ELECTRIC CORPORATION.

Open the top of container, then remove the inside packing materials and lift out the monitor carefully.

Accessories are placed at the bottom of container, and/or the top of packing materials.

2.3 Installation Place

- The monitor should be placed away from the device which generates the magnetic fields, eg. transformer and motor, because the magnetic fields cause the miss-convergence.
- The sufficient ventilation is necessary for long time stable operation. So, do not block the vents of cabinet.
- In order to get the excellent display image and prevent eye fatigue, it is recommended to avoid the direct light shining to the screen of monitor.

INSTALLATION

2.4 Caution before Power ON

Please make sure that wires, components and structures are in perfect mechanical order and not damaged during transportation.

Before turning on the power switch, check the AC power line voltage and frequency and make sure that the power line voltage selector inside the cover in the rear panel is set to the proper position as follows, and the rating of fuse is identical with the fuse rating label on the rear panel.

Except the Model No. HL7925*KW is setted in the factory before shipment. Please don't touch the Voltage Selector and Fuse, if you use except HL7925*KW.

POWER LINE VOLTAGE	AC 100 ~ 120 V	AC 220 ~ 240 V
VOLTAGE SELECTOR	Set to 100 ~ 120 V position	Set to 220 ~ 240 V position

MODEL	HL7925*K	HL7925*KV	HL7925*KW
FUSE	UL/CSA Type	IEC Type	UL/CSA/IEC Type
RATING	250 V, 3.5 A	250 V, 3.15 A	250 V, 4 A
TYPE	Time Delay	Time Lag	Time Lag

How to access the VOLTAGE SELECTOR

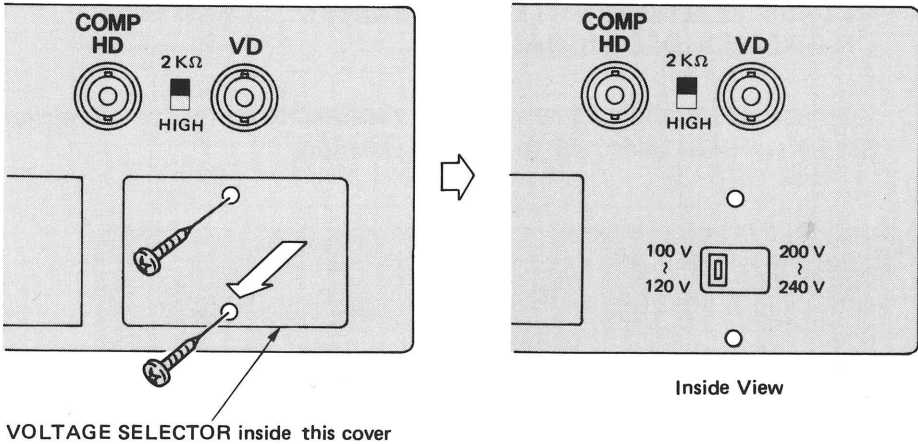

INSTALLATION

2.5 Degaussing

(Degaussing is required whenever the monitor is installed or moved)
to other place. Degaussing procedure is explained in 3.1 ⑦ .

When it is necessary to degauss the monitor absolutely, it is advised to use a degaussor.

The procedure of degaussing used by a degaussor is as follows.

- (1) The degaussor should be turned on more than six feet away from the monitor.
- (2) Approach it to the monitor with moving in a circular motion, then move it around slowly along the screen, top and sides of the monitor a few times.
- (3) Take back the degaussor from the monitor gradually with moving in a circular motion, then turn it off more than six feet away from the monitor.

2.6 Connection of Signal Cables

The signal cable should be made with 75 ohm coaxial cable.
(Type RG59/U or equivalent)

- (1) IN CASE OF A COMPOSITE SYNC. SIGNAL
ON GREEN VIDEO SIGNAL

Connect R,G,B video signals to BNC receptacles on rear panel respectively.
Set 2 K Ω /HIGH select SW to "2 K Ω " position.

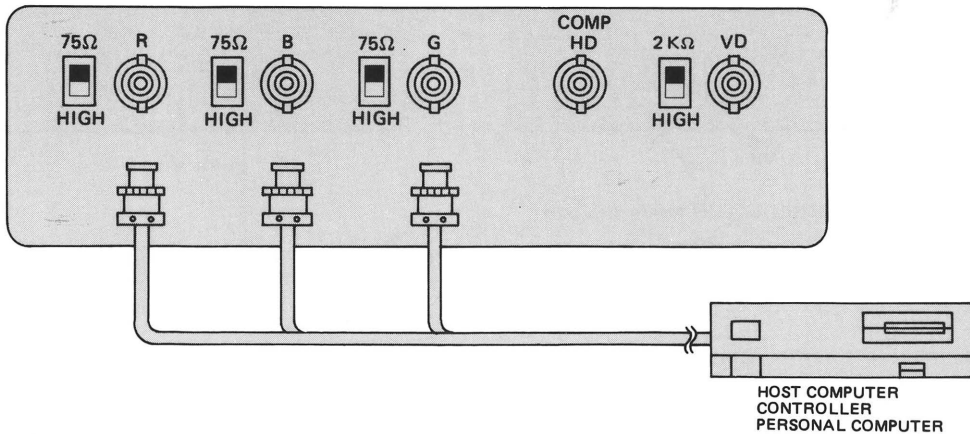

INSTALLATION

(2) IN CASE OF COMPOSITE EXT. SYNC. SIGNAL

Connect R,G,B video signals and Composite sync. signal to BNC receptacles on rear panel respectively.

Set 2 K Ω /HIGH select SW to "2 K Ω " position.

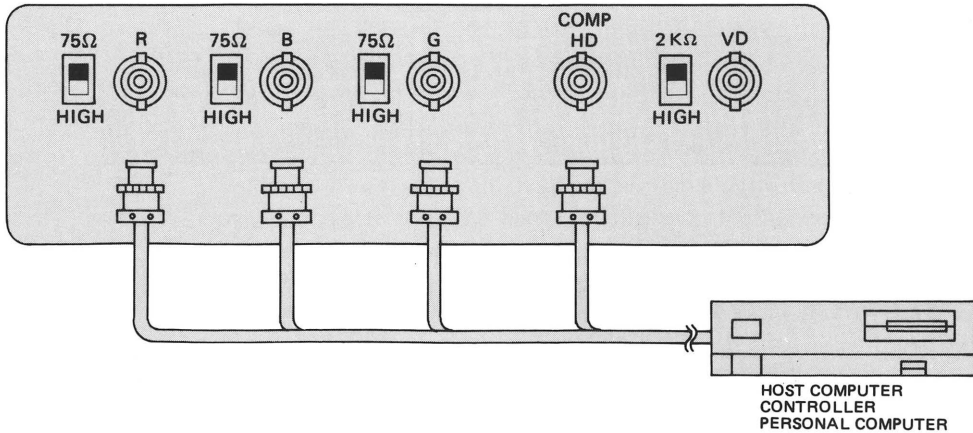

(3) IN CASE OF SEPARATE HORIZONTAL AND VERTICAL SYNC. SIGNALS

Connect R,G,B video signals and horizontal, vertical sync. signals to BNC receptacles on rear panel respectively.

Set 2 K Ω /HIGH select SW to "2 K Ω " position.

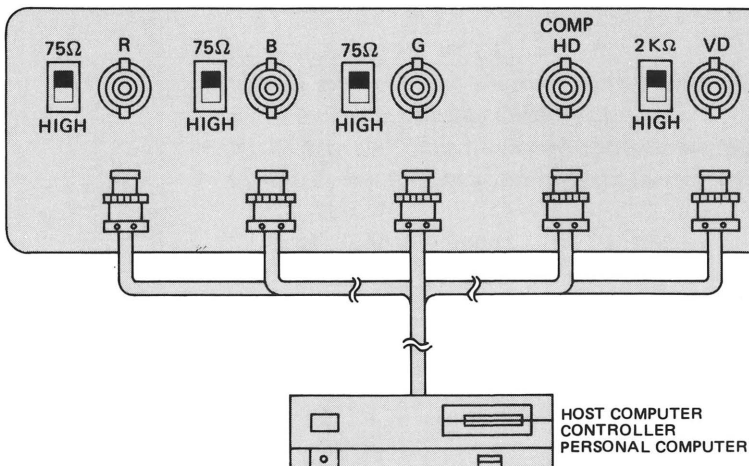

INSTALLATION

(4) IN CASE OF OPERATING MONITORS IN A LOOP THROUGH STRINGS.

Set the all of "75Ω/HIGH" or "2 KΩ/HIGH" switches of all monitors, except the last unit, with loop through strings to "HIGH" and terminate the last monitor to 75Ω, or 2 KΩ.

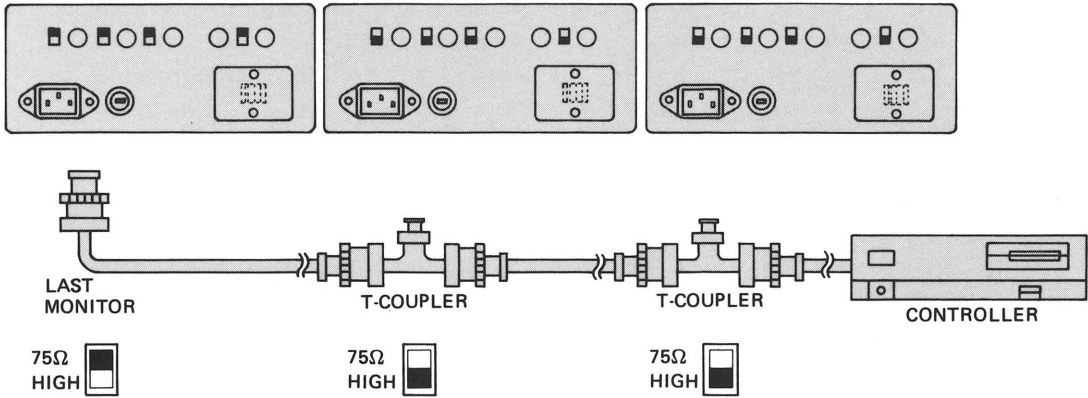

3. CONTROLS LOCATION AND DESCRIPTION

3.1 Under normal operation

FRONT CONTROLS

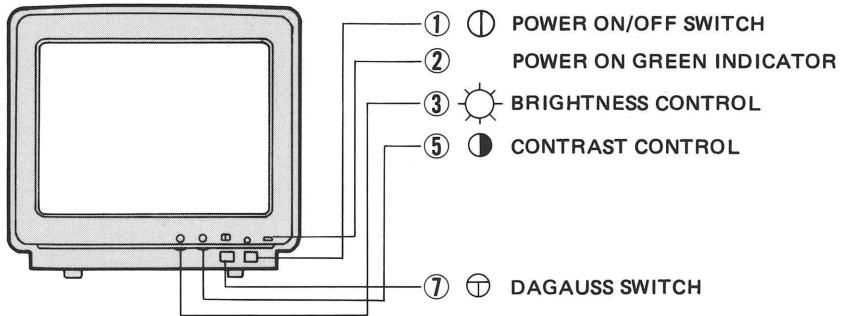

SIDE LID CONTROLS

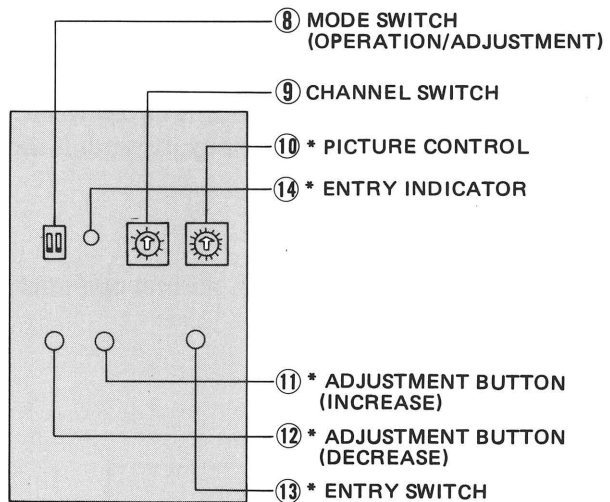
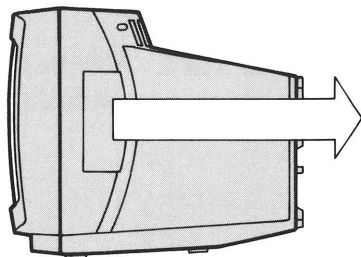

REAR PANEL CONTROLS

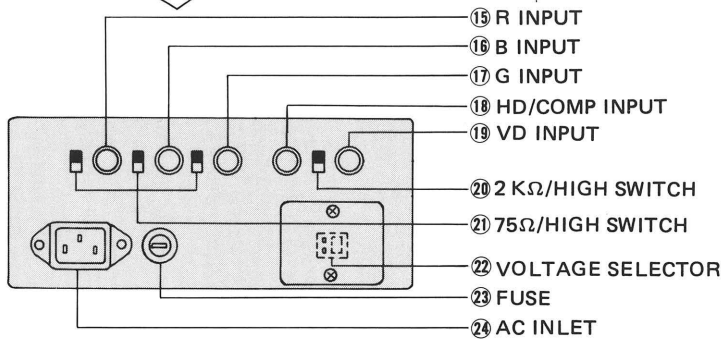
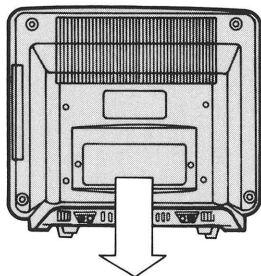

((NOTE)) CONTROLS WITH " * " ARE USED WHEN ADJUSTING THE PICTURE DIMENSIONS.

CONTROLS LOCATION AND DESCRIPTION

① POWER ON/OFF SWITCH

Push the button then the green indicator ② will illuminate and the power on. Push the button again then the power off and the green indicator ② will go off.

② GREEN INDICATOR

The green LED is provided for indicating that the main power supply is working.

③ BRIGHTNESS CONTROL

Turn BRIGHTNESS CONTROL ③ clockwise for greater brightness.

⑤ CONTRAST CONTROL

Turn CONTRAST CONTROL ⑤ clockwise for deeper contrast.

⑦ DEGAUSS SWITCH

Push the button for a short time to work the degauss circuit. Also this monitor has an automatic degauss circuit working at every power switched on.

⑧ MODE SWITCH

Set OPERATION MODE in normal operation.

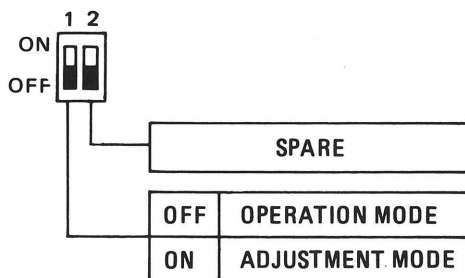

CONTROLS LOCATION AND DESCRIPTION

⑨ CHANNEL SWITCH

Select the CHANNEL needed. (See section 2.3)

CHANNEL		
CH 0	Pre-settable by user (11 timings)	AUTO CHANNEL
CH 1 to CH 7	Pre-settable by user (1 timing for each CH)	ENHANCED CHANNEL
CH 8	VGA 3 modes	
CH 9		

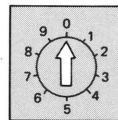

⑮ R INPUT

Connect red video signal.

⑯ B INPUT

Connect blue video signal.

⑰ G INPUT

Connect green video signal with composite sync. or without composite sync. signal.

⑱ HD/COMP INPUT

Connect horizontal sync. signal when using separate external, or composite sync. signal when using composite external.

⑲ VD INPUT

Connect vertical sync. signal when using separate ext. sync. signal.

CONTROLS LOCATION AND DESCRIPTION

⑩⑪ 75Ω/HIGH SWITCH / 2 KΩ/HIGH SWITCH

For "Single-Unit" operation, set to "75Ω" or "2 KΩ" position. For "Loop-thru-Strings" operation, set to "HIGH" position for all units except the last one, and the last one be set at "75Ω" or "2 KΩ" position.

Operation	Switch Position	
	75Ω/2 KΩ	HIGH
Single-Unit	YES	NO
Loop-thru-Strings	YES Last unit only	YES

NOTE: "T-coupler" must be used for "Loop-thru-Strings".

⑫ VOLTAGE SELECTOR (under the cover)

⑬ FUSE

⑭ AC INPUT

Connect AC power cord.

CONTROLS LOCATION AND DESCRIPTION

3.2 When adjusting the picture dimensions

SIDE LID CONTROLS

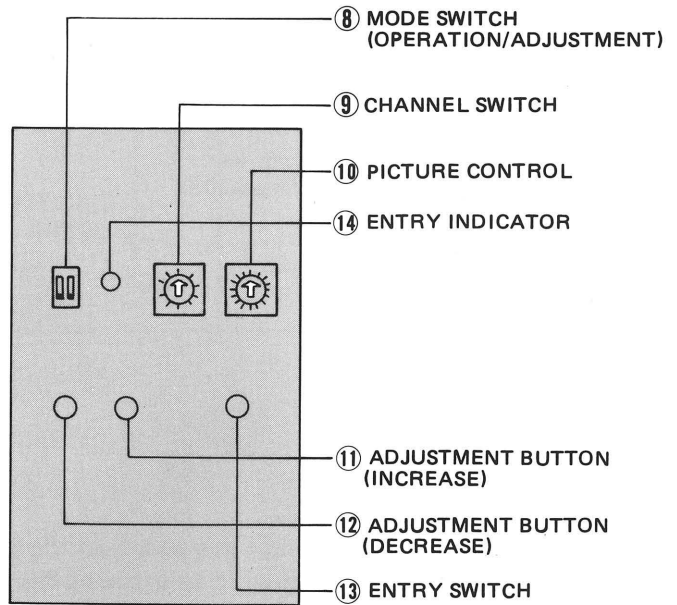
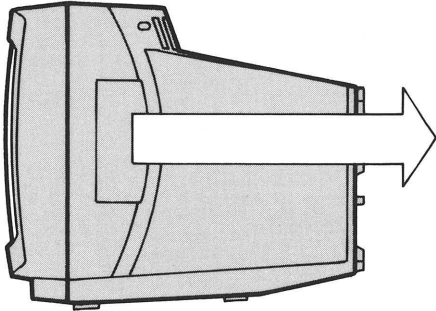

⑧ MODE SWITCH

Set **ADJUSTMENT MODE** on when you start adjusting the picture dimensions.

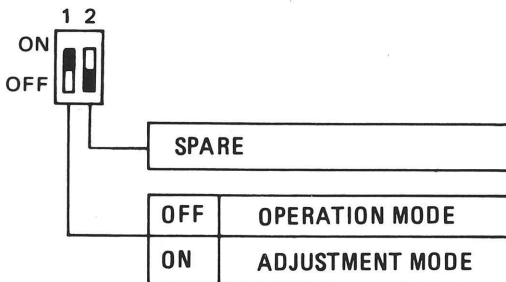

CONTROLS LOCATION AND DESCRIPTION

⑨ CHANNEL SWITCH

Select the CHANNEL needed. (See section 2.3.)

CHANNEL		
CH 0	Pre-settable by user (11 timings)	AUTO CHANNEL
CH 1 to CH 7	Pre-settable by user (1 timing for each CH)	ENHANCED CHANNEL
CH 8	VGA 3 modes	
CH 9		

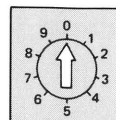

⑩ PICTURE CONTROL

Select necessary number as you adjust the picture dimensions.
Numbers present following adjustment items.

0	SPARE	Re-adjust these items according to the input signal timing.
1	H-PHASE	
2	H-SIZE	
3	H-POSITION	
4	V-POSITION	
5	V-SIZE	
6	V-SIZE-FINE	Re-adjust these items if necessary.
7-9	SPARE	
A	PCC-AMP	
B	PCC-PHASE	
C-F	SPARE	

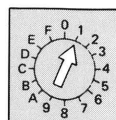

CONTROLS LOCATION AND DESCRIPTION

⑪ ADJUSTMENT BUTTON (INCREASE)

⑫ ADJUSTMENT BUTTON (DECREASE)

When ADJUSTMENT BUTTON ⑪ or ⑫ is pushed, motions of adjustment items are as follows.

BUTTON ⑤	BUTTON ⑥
WIDEN	NARROW
SHIFT TO RIGHT	SHIFT TO LEFT
UP	DOWN

⑬ ENTRY SWITCH

Push when you make entry of new timing into the internal memory.

⑭ ENTRY INDICATOR

At the entry, if the picture data is memorized, ENTRY INDICATOR ⑨ is lit for about 0.5 second.

If not, it blinks.

CONTROLS LOCATION AND DESCRIPTION

3.3 EXPLANATION ON CHANNEL

CHANNEL must be selected properly when the monitor is normally used, or when you want to adjust the picture dimensions.

This monitor has 10 CHANNELS and they are classified into two types of CHANNEL.

CHANNEL	TYPE OF CHANNEL
CH 0	AUTO CHANNEL
CH 1 to CH 9	ENHANCED CHANNEL

Structure of CHANNEL is as follows.

[CHANNEL SWITCH]

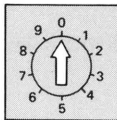

CHANNEL	Pre-settable by user (11 timings)	TYPE OF CHANNEL	FREQUENCY BAND	HORIZONTAL FREQUENCY
CH 0	Pre-settable by user (11 timings)	AUTO CHANNEL	1	30kHz
CH 1	Pre-settable by user (1 timing for each CHANNEL)	ENHANCED CHANNEL	2	
CH 2			3	
CH 3			4	
CH 4			5	
CH 5			6	
CH 6			7	
CH 7			8	
CH 8	VGA Timing		9	
CH 9			10	
			11	78kHz

The characteristic for each CHANNEL is shown in the following table.

CONTROLS LOCATION AND DESCRIPTION

CHANNEL	DESCRIPTION
AUTO CHANNEL (CH 0)	<p>This CHANNEL has 15 bands for horizontal frequency of 30 – 78 kHz and picture data can be memorized in each band.</p> <p>(1) <u>IN OPERATION MODE</u> When in OPERATION MODE, monitor displays the picture with the size and position as memorized in the band corresponding with the horizontal frequency of input sync. signal.</p> <p>(2) <u>IN ADJUSTMENT MODE</u> In case of pre-setting the new picture dimensions, the data concerned is memorized in the band corresponding with the horizontal frequency of input sync. signal. Difference between adjacent each horizontal frequency should be kept 3kHz or more, because horizontal frequency which monitor counts has little discrepancy from that of input signal.</p>
ENHANCED CHANNEL (CH 1 – CH 9)	<p>This ENHANCED CHANNEL has 9 CHANNELs and 1 (one) specified timing can be memorized in each CHANNEL.</p> <p>(1) <u>IN OPERATION MODE</u> When horizontal frequency of input signal matches that of selected CHANNEL, monitor displays the picture of the size and position as memorized in the selected CHANNEL. When horizontal frequency of input signal is different from that of selected CHANNEL, monitor displays the picture of the size and position which is memorized in the band of AUTO CHANNEL (CH 0) corresponding to the horizontal frequency of input sync. signal.</p> <p>(2) <u>IN ADJUSTMENT MODE</u> In case of pre-setting the new picture dimensions, the data concerned is memorized in selected CHANNEL. In CH 1 to CH 7, the timing which customer requests can be memorized. In CH 8 the following timings are memorized at factory.</p> <p style="text-align: center;">CH 8 : IBM VGA mode</p>

4. ADJUSTMENT

4.1 Preparation

In the following adjustment procedures, some condition is assumed as follows.

- AC Power source with proper voltage and frequency is supplied, and the power line voltage selector in the rear panel is set to the proper position. (refer to item 2.4)
- Video signals with proper line rate are applied to the red, green and blue inputs. And either the green video signal with composite sync. or a proper external sync. signal is also applied, then the sync. selector switch is set to the proper position. (refer to item 2.6)
- Before starting adjustments, it is supposed to degauss every part of the monitor and Warm-up the monitor with displaying a picture more than 20 minutes.

4.2 Procedure

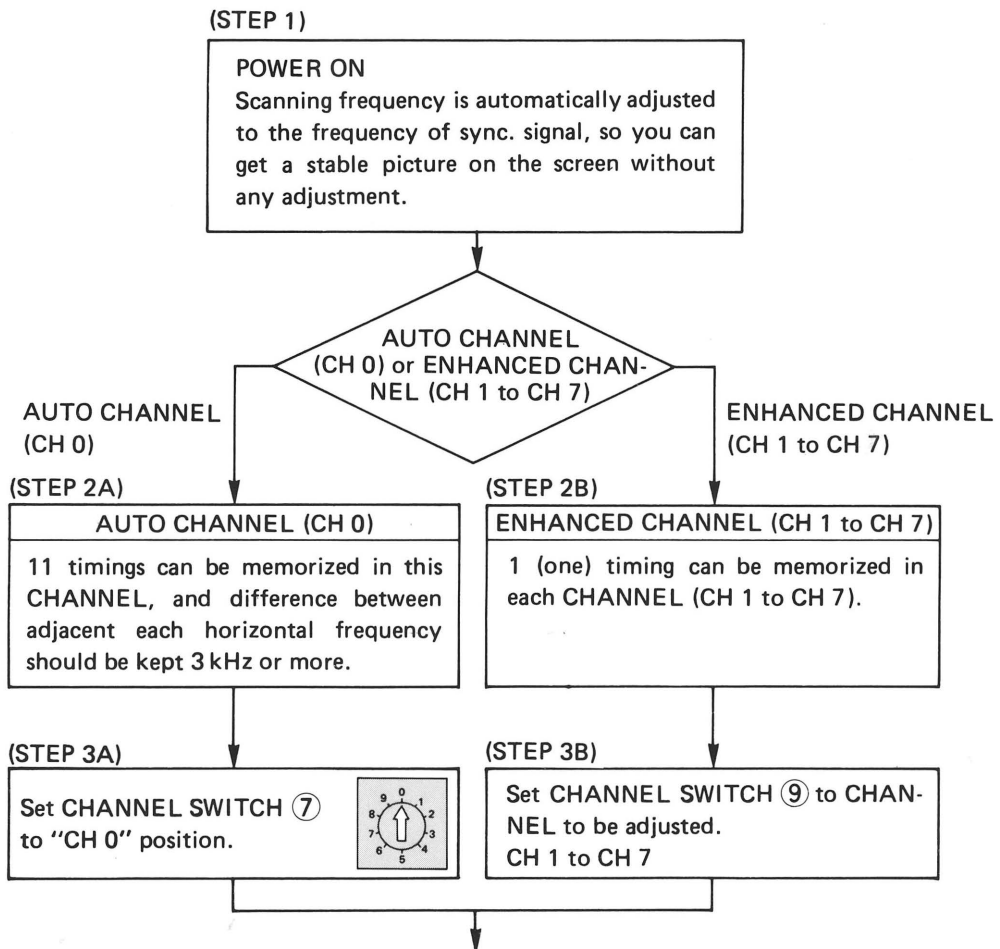

ADJUSTMENT

(STEP 4)

Set No. 1 of MODE SWITCH (8) to "ON" position.

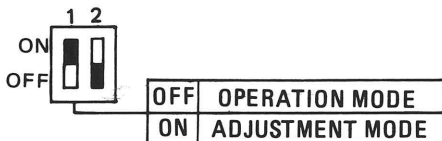

(STEP 5)

Set PICTURE CONTROL (10) to the number (adjustment item) necessary.

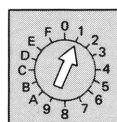

NO.	ADJUSTMENT ITEM	REMARKS
0	SPARE	
1	H-PHASE	Re-adjust these items according to the input signal timing.
2	H-SIZE	
3	H-POSITION	
4	V-POSITION	
5	V-SIZE	
6	V-SIZE-FINE	
7-9	SPARE	
A	PCC-AMP	Re-adjust these items if necessary. (timing free items)
B	PCC-PHASE	
C-F	SPARE	

(STEP 6)

Adjust picture size and position by ADJUSTMENT BUTTON (11), (12).

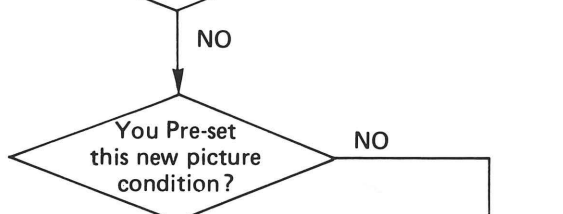
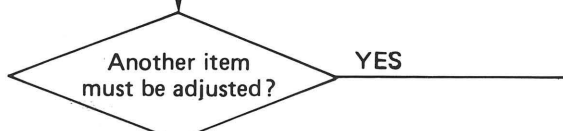

GO TO (STEP 10)

ADJUSTMENT

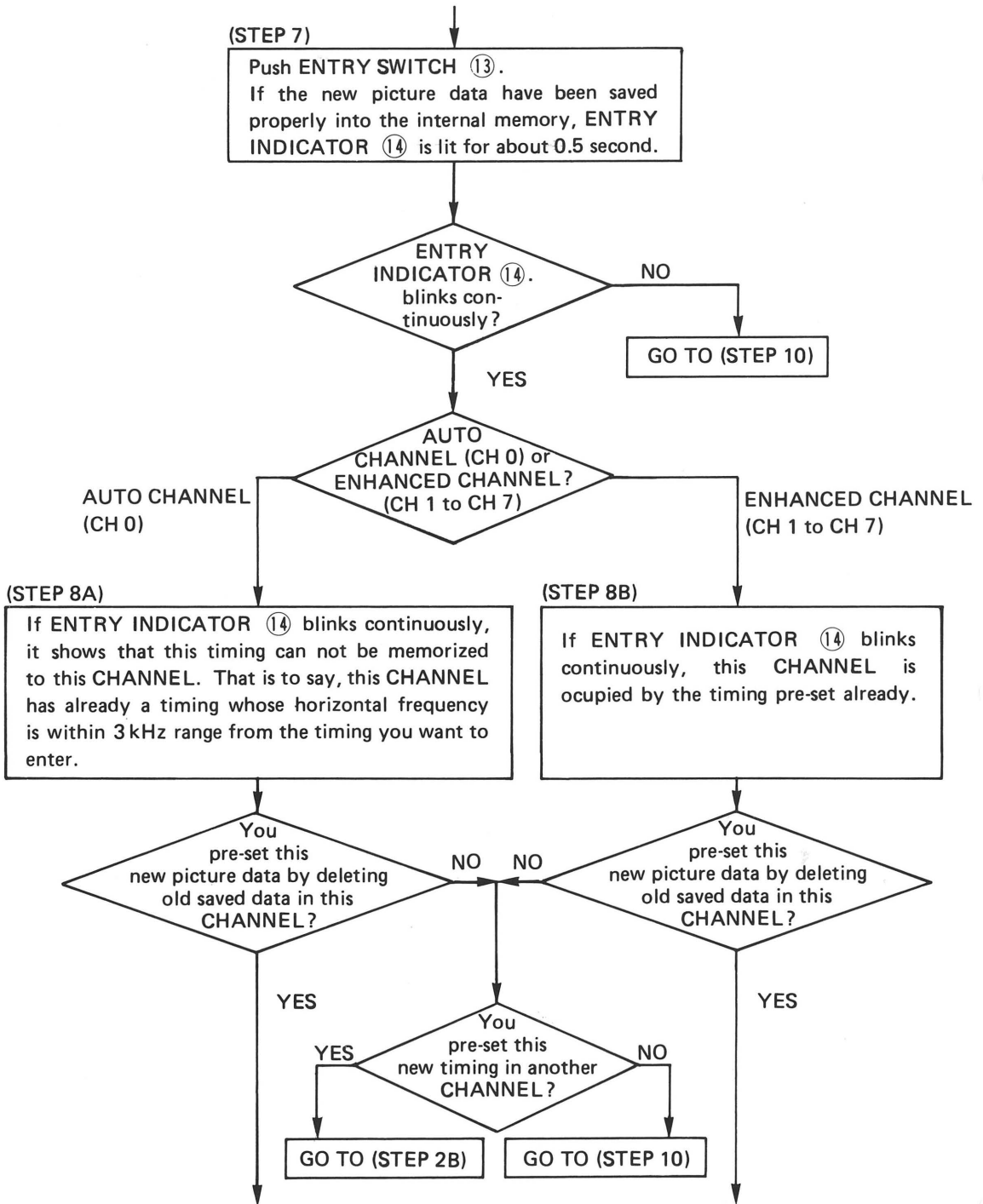

ADJUSTMENT

(STEP 9A)

Push ENTRY SWITCH ⑬ once more.
If the new picture data have been saved properly into the internal memory, ENTRY INDICATOR ⑭ is lit for about 0.5 second.
(NOTE) In this case, old saved timings within 3kHz range in horizontal frequency will be deleted automatically.

(STEP 9B)

Push ENTRY SWITCH ⑬ once more.
If the new picture data have been saved properly into the internal memory, ENTRY INDICATOR ⑭ is lit for about 0.5 second.
(NOTE) In this case, old saved timing in this CHANNEL will be deleted automatically.
Besides in CH 8 the following timings are memorized at factory.

CH 8 : VGA

(STEP 10)

Set No. 1 of MODE SWITCH ⑧ to "OFF" position.

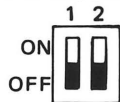

OFF	OPERATION MODE
ON	ADJUSTMENT MODE

END

ADJUSTMENT

4.3 What picture comes out ?

(EXAMPLE 1)

Following 3 timings are memorized in AUTO CHANNEL (CH 0).

- T1 (fH = 31.5 kHz)
- T2 (fH = 48 kHz)
- T3 (fH = 64 kHz)

(CHANNEL SWITCH) (AUTO CHANNEL (CH 0))

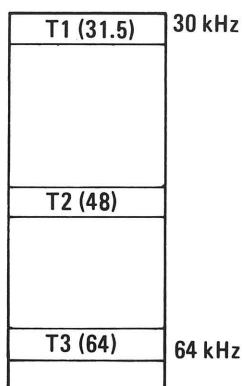
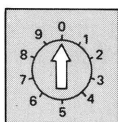

WHAT PICTURE COMES OUT?

In this case, relationship between input signal and memorized timing is as follows.

HORIZONTAL FREQ. OF INPUT SIGNAL	MEMORIZED TIMING CORRESPOND TO INPUT SIGNAL
--	--

31.5 kHz	→	T1 (31.5)
48 kHz	→	T2 (48)
64 kHz	→	T3 (64)

Since above 3 timings are memorized in AUTO CHANNEL (CH 0), the range of horizontal frequency of new timings which are available for additional pre-setting without deleting them is as follows.

fH = 34.5 – 45 kHz, 51 – 61 kHz, 68 ~ 78 kHz

ADJUSTMENT

(EXAMPLE 2)

Following 3 timings are memorized in AUTO CHANNEL (CH 0) and 2 timings are memorized in ENHANCED CHANNEL (CH 1 and CH 2).

AUTO CHANNEL : CH 0 T1 ($f_H = 31.5$ kHz, $f_V = 60$ Hz, H sync. pol = -, V sync. pol = -)
 T2 ($f_H = 48$ kHz, $f_V = 60$ Hz, H sync. pol = -, V sync. pol = -)
 T3 ($f_H = 64$ kHz, $f_V = 60$ Hz, H sync. pol = -, V sync. pol = -)
 ENHANCED CHANNEL: CH 1 T4 ($f_H = 30.5$ kHz, $f_V = 70$ Hz, H sync. pol = -, V sync. pol = -)
 CH 2 T5 ($f_H = 48$ kHz, $f_V = 60$ Hz, H sync. pol = +, V sync. pol = +)

WHAT PICTURE COMES OUT?

When CH 1 (ENHANCED CH) is selected, relationship between input signal and memorized timing is as follows.

Frequency and Polarity of horizontal and vertical input sync. signal.

Memorized Timing correspond to input signal.

f_H	f_V	H sync. pol	V sync. pol	
48 kHz	60 Hz	-	-	→ VGA (480 LINE MODE)
31.5 kHz	60 Hz	-	-	→ T2
48 kHz	60 Hz	+	-	→ T5
30.5 kHz	70 Hz	-	-	→ T4

CHANNEL No.	Memorized Timing	Memorized Item of Timing				CHANNEL Classification
		f_H (kHz)	f_V (Hz)	H sync. Pol (+/-)	V sync. Pol (+/-)	
CH 0	T1	31.5				AUTO CHANNEL (See Table b)
	T2	48.0				
	T3	64.0				
CH 1	T4	30.5	70	-	-	Enhanced CHANNEL
CH 2	T5	48.0	60	+	-	
CH 3						
CH 4						
CH 5						
CH 6						
CH 7						
CH 8	VGA 480L	31.5	60	-	-	
	VGA 400L	31.5	70	-	+	
	VGA 350L	31.5	70	+	-	
CH 9				+	+	

Table (a)

Auto CHANNEL (CH 0)

T1 (31.5)	30 kHz
T2 (48.0)	
T3 (64.0)	
	78 kHz

Table (b)

5. QUICK CHECK

Belows are some common problems you may encounter. Refer to this check list before contacting a service technician.

5.1 Monitor screen is blank

- (1) Check brightness and contrast controls, and adjust to maximum brightness by turning the control ③.
- (2) Check power.
 - Verify that the power-on indicator on the front of the monitor is illuminated.
 - Check whether the power cord is plugged into the electrical outlet, and/or the AC inlet of the monitor.
 - Confirm that the electrical outlet is active and works properly.
 - Confirm that the power line voltage selector is set to the proper position. (refer to item 2.4)
- (3) Check connection.
 - Check that your generator or the computer outputs some image.
 - Check that the video signal cables and the sync. signal cables are correctly connected to the monitor. (refer to item 2.6)
 - Check that the input impedance selector switches are set to proper position.

5.2 Monitor screen image is too dim or bright

- (1) Check brightness and contrast controls. (refer to 5.1 (1))
- (2) Check connection. (refer to 5.1 (3))

5.3 Monitor generates beep sound

- (1) Check power.
 - Confirm that the power line voltage selector is set to the proper position. (refer to item 2.4)
 - Confirm that the electrical outlet works properly.
- (2) Check that the horizontal picture width is controlled properly.
 - When the horizontal picture width is set too wide, the protection circuit in the monitor is activated.
Beep sound is generated and the both side of the picture fluctuates during the protection circuit active.
Please adjust the horizontal width control to get narrower picture.

5.4 Booming sound just after power "ON"

- (1) It is not accident because of the sound when each time you turn on the display monitor, auto degaussing circuit moving itself, and the booming sound (3 ~ 4 sec.) occur.

5.5 Monitor screen is not stable

Input signals which are in the horizontal scanning frequency range of 30 kHz ~ 78 kHz, and in the vertical scanning frequency range of 50 Hz ~ 120 Hz, can be automatically locked on and displayed on the screen by the auto-tracking function.

If you can not get the stable picture on the screen, please check followings.

- (1) Check connection. (refer to 5.1 (3))
- (2) Check the level of the sync. signals.
The level of the sync. signal are shown in item 1.2 when using composite external sync.
- (3) Confirm the horizontal scanning frequency, and the vertical scanning frequency.
 - The monitor can accept only following signals.

Horizontal scanning frequency	30 kHz – 78 kHz
Vertical scanning frequency	50 Hz – 120 Hz
- (4) It is normal for this monitor to need approx. 5 seconds after the sync. signals provided for locking on, and displaying a stable picture.

6. CARE and MAINTENANCE

6.1 General

Provided the color display monitor is connected to the proper power source and is handled gently, it should give you a long period of trouble-free productivity. If there is an occasion when you suspect a malfunction with the unit, unplug the set and have it checked by your qualified service technician for conditions such as:

- The set has been dropped or the cabinet has been damaged.
- The set has been exposed to rain or water.

If you are unable to restore normal operation by following the procedures in this guide, do not attempt any further adjustments as improper adjustment of other controls will result in damage. Unplug the set and call your dealer.

If the set fails, or exhibits a distinct change in performance, then this indicates a need for service. Unplug the set and have it checked by a professional service technician.

6.2 Operation

- Operate the set only from the power source indicated on the back of the cabinet.
- To use a power source that is not marked on the back of the monitor will shorten the life of the monitor and cause damage in addition to improper operation.
- To ensure safe operation, the power plug must be inserted only into a standard three-prong power outlet which is correctly grounded through normal electrical wiring. Extension cords used with the equipment must be three-wire and be correctly wired to provide connection to the ground. Wrongly wired extension cords are a major cause of fatalities. The fact that the equipment operates satisfactorily does not imply that the power point is grounded and that the installation is completely safe. For your safety, if in any doubt about the effective grounding of the power point, consult a qualified electrician.
- For continued protection against risk of fire, replace only with same type and ratings of fuse.
- Do not overload wall outlets and extension cords as this can result in fire or shock.
- Adjust only those controls that are described in this guide. Improper adjustment of other controls may result in damage and could require the services of a technician to restore proper operation.
- Do not allow anything to rest on the power cord. Do not locate this monitor where the cord will be abused by persons walking on it.
- When not using the set for extended periods of time, such as a weekend or vacation, unplug the set from the wall outlet.

CARE and MAINTENANCE

- If the same characters or graphics are shown for a long time with the Brightness and Contrast controls set to maximum positions, part of the screen may become damaged. Use these controls with care.
- Do not remove the back cover of the set as this can expose you to very high voltages and other hazards.
- Do not drop or push objects into the cabinet openings. Some internal parts carry hazardous voltages and contact can result in electrical shock or fire.
- Never operate the set near water.
- Never spill liquid of any kind on the monitor. If liquid has accidentally spilled into it, unplug the set and have it checked by a service technician.

6.3 Cleaning

- Always unplug the monitor before cleaning.
- Wipe the screen and cabinet front and sides with a soft cloth.
- If the screen requires more than dusting, apply a household window cleaner to a soft cloth to clean the monitor screen.

Caution — Do not use benzene, thinner or any volatile substances to clean the unit as the finish may be permanently marked. Never leave the unit in contact with rubber or vinyl for an extended period.

WORLD-WIDE DISTRIBUTION/SERVICE NETWORK

Country	Company	Address	Phone No. Fax. No.
Japan	Mitsubishi Electric Corporation	Mitsubishi Denki Bldg., Marunouchi, Tokyo 100, Japan	(03) 218-2111 (03) 218-2894
U.S.A.	Mitsubishi Electronics America, Inc.	991 Knox Street, Torrance, California 90502, U.S.A.	(213) 515-3993 (213) 324-6578
Canada	Mitsubishi Electric Sales Canada, Inc.	8885 Woodbine Avenue, Markham, Ontario L3R 5G1, Canada	(416) 475-7728 (416) 475-7861
United Kingdom	Mitsubishi Electric (U.K.) Ltd.	Travellers Lane Hatfield Herts AL10 8XB, U.K.	07072 76100 07072 78692
West Germany	Mitsubishi Electric Europe, GmbH	Gothaer Strasse 8, Postfach 1548, D-4030 Ratingen 1, West Germany	(2102) 4860 (2102) 486-112
France	Mitsubishi Electric France S.A.	65, Avenue de Colmar, Tour Albert ler, 92507, Rueil Malmaison, Cedex, France	(1) 47-52-96-40 (1) 47-08-04-05
Sweden	Mitsubishi Electric Scandinavia AB	Lastbilsvagen 6b S-191 49 Sollentua, Sweden	(8) 960460 (8) 966877
Australia	Mitsubishi Electric Australia Pty., Ltd.	73-75 Epping Rd., North Ryde, P.O. Box 1567, Macquarie Centre, N.S.W. 2113, Australia	(2) 888-5777 (2) 887-3635
Taiwan	Melco Taiwan Co., Ltd.	Chung-Ling Bldg., No. 363, Sec. 2, Fu-Hsing S. Rd., Taipei, Taiwan, R.O.C.	(2) 733-3030 (2) 735-6244
Hong Kong	Mitsubishi Electric (H.K.) Ltd.	25th Floor, Leighton Centre, 77 Leighton Rd., Causeway Bay, Hong Kong	(5) 773901 123-4345
Singapore	Melco Sales Singapore Pte., Ltd.	230 Upper Bukit Timah Rd., #03-01/15, Hock Soon Industrial Complex, Singapore 2158	4695255 469-5347