

# Service Manual

VIDEO MONITOR  
WV-5470

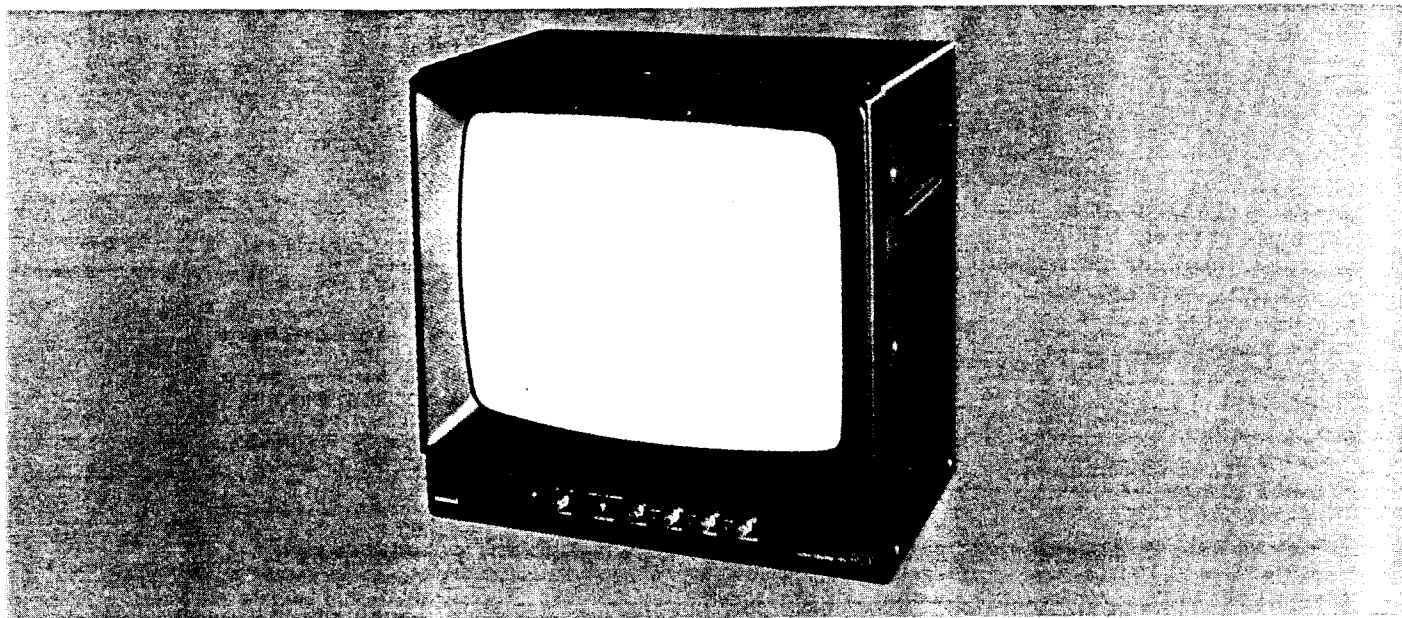

## SPECIFICATIONS

Power Source:	WV-5470E/A: 240V AC, 50 Hz WV-5470E/C: 220V AC, 50 Hz WV-5470N: 115V or 230V AC resettable, 50/60 Hz
Power Consumption:	Approx. 45 watts
Video Input:	0.5~2.0 Vp-p composite/75Ω or Hi-Z looping through
Video Frequency Response:	More than 10 MHz
Horizontal Resolution:	More than 850 lines at center
Maximum Video Gain:	42 dB
H. AFC Time Constant:	Short time constant for industrial VTRs
Sweep Linearity:	Less than 5% at overscan
Sweep Geometry:	Less than 2% at overscan
Overscanning:	Approx. 5%
Scanning Size:	Overscan or underscan switchable
DC Restoration:	Yes
CRT:	17" diagonal (16-1/4" diagonal actual visual size)
High Voltage:	DC 15kV
Rackmounting:	Yes (with optional rack angle brackets)
Ambient Operating Temperature:	-10°C ~ +50°C
Ambient Operating Humidity:	Less than 90%
Dimensions:	420 (W) x 411 (H) x 378 (D) mm
Weight:	15 kg

 **National/Panasonic**

**Matsushita Electric Trading Co., Ltd.**  
P.O. Box 288, Central Osaka Japan

# MAJOR OPERATING COMPONENTS

< FRONT VIEW >

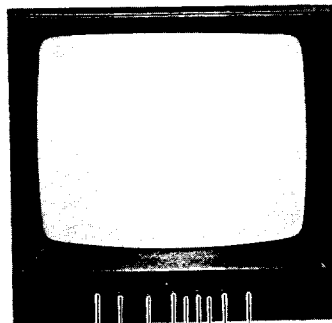

< REAR VIEW >

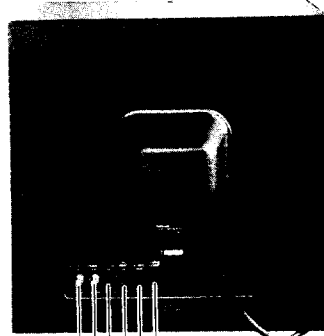

- ① Power Switch [POWER OFF/ON]
- ② Scan Size Switch [SCAN SIZE UNDER/NORMAL]
- ③ Horizontal Hold [H-HOLD]
- ④ Height [HEIGHT]
- ⑤ Vertical Hold [V-HOLD]
- ⑥ Vertical Linearity [V-LIN]
- ⑦ Brightness [BRIGHT]
- ⑧ Focus [FOCUS]
- ⑨ Contrast [CONTRAST]

- ⑩ Video Input Connector (BNC) [VIDEO IN]
- ⑪ Video Output Connector (BNC) [VIDEO OUT]
- ⑫ Video Termination Switch [VIDEO 75Ω/Hi-Z]
- ⑬ DC Restoration Switch [DC REST ON/OFF]
- ⑭ H. AFC Switch [H. AFC SHORT/LONG]
- ⑮ Cable Loss Compensation Switch [CABLE COMP S/L]

## CONTROLS AND THEIR FUNCTIONS

- ① Power Switch [POWER OFF/ON]  
Turns power ON and OFF.
- ② Scan Size [SCAN SIZE UNDER/NORMAL]  
Underscanning is obtained when depressed.
- ③ Horizontal Hold [H-HOLD]  
Locks in the picture horizontally.
- ④ Height [HEIGHT]  
Adjust the height of the picture.
- ⑤ Vertical Hold [V-HOLD]  
Locks in the picture vertically.
- ⑥ Vertical Linearity [V-LIN]  
Adjusts for vertical distortion of the picture.
- ⑦ Brightness Control [BRIGHT]  
Turning this control clockwise increases the overall brightness.
- ⑧ Focus [FOCUS]
- ⑨ Contrast Control [CONTRAST]  
Turning this control clockwise increases the picture contrast.
- ⑩ Video Input Connector [VIDEO IN] (BNC)
- ⑪ Video Output Connector [VIDEO OUT] (BNC)
- ⑫ Video Termination Switch [VIDEO 75Ω/Hi-Z]  
When bridging or looping through the video signal, set this switch to Hi-Z position, and for other cases this switch should be set to 75Ω position.
- ⑬ DC restoration Switch [DC REST ON/OFF]  
Switch to restore background of the picture.
- ⑭ H. AFC Switch [H. AFC SHORT/LONG]  
Switch to SHORT position (short H. AFC time constant) for VTR playback.
- ⑮ Cable Loss Compensation Switch  
See page 2.

# CONNECTIONS

## Power Cable

1. Keep the Monitor Power Switched OFF during connection.
2. Connect the Power Cord to a grounded electrical outlet.

## Video Cable

1. Terminate the camera's output in a 75-ohm resistor at the furthest end of its cable run.
- Always set the last monitor's Termination Switch ⑫ to **75Ω**, and set the Termination Switches ⑫ of intermediate monitors to **Hi-Z**.

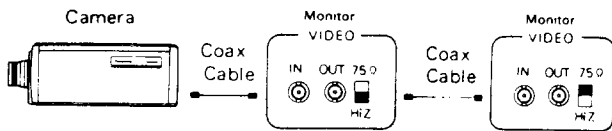

- Use 75-ohm coaxial cable. (3C-2V, 5C-2V, 7C-2V, 10C-2V)
- 2. Up to 10 monitors can be hooked up in this configuration before signal loss occurs. Total cable length should not exceed 150m.
- 3. Wiring Precautions:
  - Do not bend coaxial cable into a curve whose radius is smaller than 10 times its diameter.
  - Never staple the cable — not even with circular staples.
  - Never crush or pinch the cable.

All these will change the impedance of the cable and cause poor picture quality.

## Cable Loss Compensation Switch

1. Normally set this switch to **S** position.



2. When the cable is so long that the resolution deteriorates, select the appropriate coaxial cable and switch position according to the cable length as shown in the table.

(Unit: m)

Position of Switch \ Kinds of Cable	3C-2V	5C-2V	7C-2V	10C-2V
	S (Short)	250	500	600
L (Long)	500	750	1000	1250

3. A thicker coaxial cable is preferred and switch position **S** is most appropriate.
4. If many monitors are to be bridge-connected, choose the cable by the distance to the last monitor, and select the switch position of each monitor so that the best picture quality can be obtained.

## System Connections

1. Single Monitor Connection

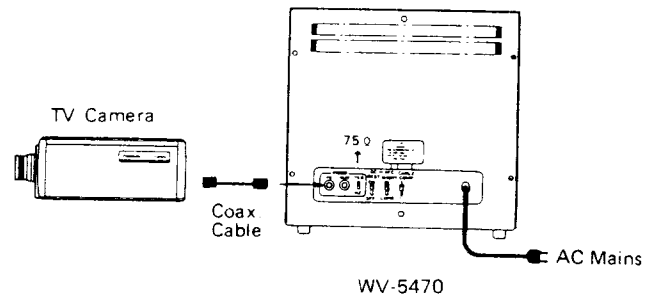

- Connect the Video Input Connector ⑩ on the monitor to the Video Out Connector of the camera with 75-ohm coaxial cable.
- Set the Video Termination Switch ⑫ to **75Ω** position.

2. Multiple Monitor Connection

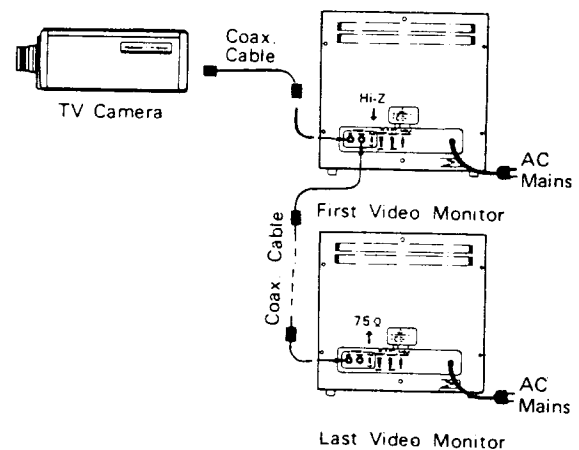

- Connect the Video Input Connector ⑩ on the video monitor to the Video Out Connector of the camera with 75-ohm coaxial cable.
- Connect the Video Output Connector ⑪ on the first monitor to the Video Input Connector ⑩ on the second monitor with 75-ohm coaxial cable. Continue until all monitors are connected.
- Set the Video Termination Switch ⑫ of the first and intermediate monitors to **Hi-Z** position. Then set the Video Termination Switch ⑫ of the last monitor to **75Ω** position.

# ADJUSTMENT

## ■ TEST EQUIPMENT

- TV camera or Video Signal Generator
- Coaxial Cable (Impedance: 75Ω)
- Resolution Chart (YWV1400RB99)

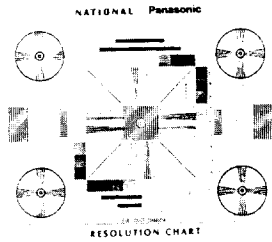

Fig. 1

## ■ SET UP FOR ADJUSTMENT

### 1) Adjustment using TV camera

- Connect the coaxial cable between the TV camera and the input of video monitor.
- Terminate the video input of monitor with 75 ohms.
- Position the resolution chart (YWV1400RB99) in front of the TV camera as shown in Fig. 2.

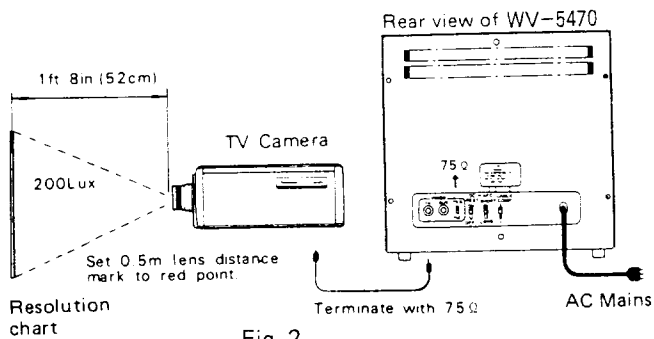

Fig. 2

### 2) Adjustment using video signal generator

- Connect the coaxial cable between the output of video signal generator and the input of video monitor.
- Set the video signal generator so that it provides the cross-hatch signal.

## ■ DISASSEMBLING FOR ADJUSTMENT

- Remove thirteen screws fixing the upper cover and remove the cover.(Fig. 3)

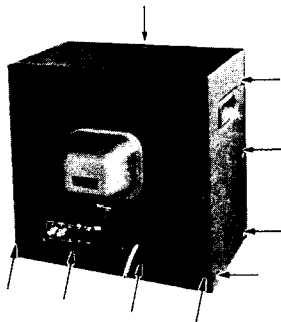

Fig. 3

→ Remove the screws.

- Remove the bottom cover by removing the six fixing screws.

## ■ ADJUSTMENT PROCEDURE

- Refer to page 5 for adjusting controls.
- Observe the monitor screen during the adjustment.

### 1. Vertical hold adjustment

Adjusts: VR5 (V. HOLD)  
VR9 (V. SUB HOLD)

- Set V. HOLD VR5 at mechanical center.
- Adjust V. SUB HOLD VR9 to hold picture vertically.

### 2. Horizontal hold adjustment

Adjusts: VR6 (H. HOLD)  
VR10 (H. SUB HOLD)

- Set H. HOLD VR6 at mechanical center.
- Adjust H. SUB HOLD VR10 to hold picture horizontally.

### 3. Picture tilt adjustment

Adjust: Deflection coil

- Set the scan size switch to the underscan position.
- Loosen the deflection coil holding screw. (Fig. 4)

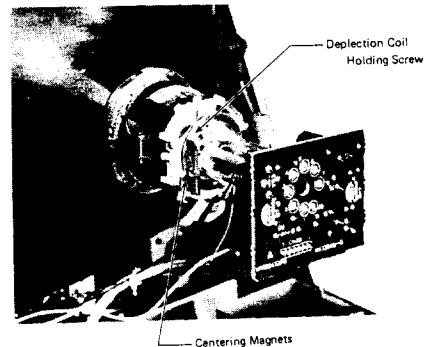

Fig. 4

- Turn the deflection coil until the raster on the monitor screen is straight.
- Carefully tighten the deflection coil holding screw.

### 4. Centering adjustment

Adjust: Centering magnets

- Keep setting the scan size switch to the underscan position.
- Adjust the centering magnets (see Fig. 4) until the raster comes to the center of monitor screen.

#### 5. Horizontal width adjustment

Adjust: L6 (H-WIDTH)

- Set the scan size switch to the normal (overscan) position.
- Adjust H-WIDTH L6 to obtain full horizontal width plus a little overscanning.

#### 6. Vertical height and linearity adjustment

Adjusts: VR8 (HEIGHT)  
VR7 (V-LIN)

- Adjust HEIGHT VR8 and V-LIN VR7 so that the circle in the chart is nearly a true circle.

#### 7. Sub-brightness adjustment

Adjusts: VR1 (CONTRAST)  
VR4 (BRIGHTNESS)  
VR3 (SUB-BRIGHTNESS)

- Set the DC restoration switch to the ON position.
- Turn CONTRAST VR1 fully counterclockwise.
- Turn BRIGHTNESS VR4 fully clockwise, and then turn it back 180 degrees counterclockwise.
- Adjust SUB-BRIGHTNESS VR3 so that the raster will just appear.

#### 8. Focus adjustment

Adjust: VR2 (FOCUS)

- Adjust VR2 for best focus in the monitor.

#### ■ VIDEO/DEFLECTION CIRCUIT BOARD REMOVAL

- When replacing the parts on the video/deflection circuit board, proceed following steps.
  - (1) Remove knobs from the front of the monitor.
  - (2) Remove two screws on the video/deflection circuit board. (Fig. 5)

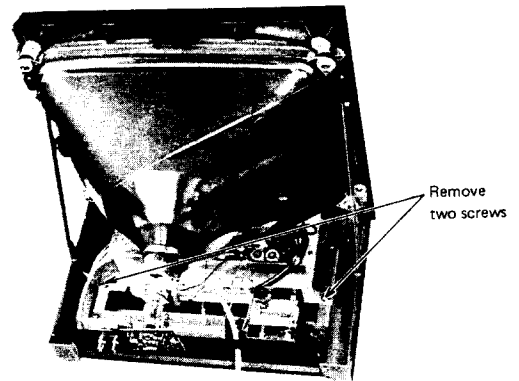

Fig. 5

- The video/deflection circuit board can be removed backward. (Fig. 6)

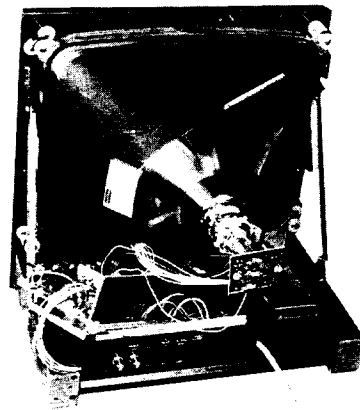
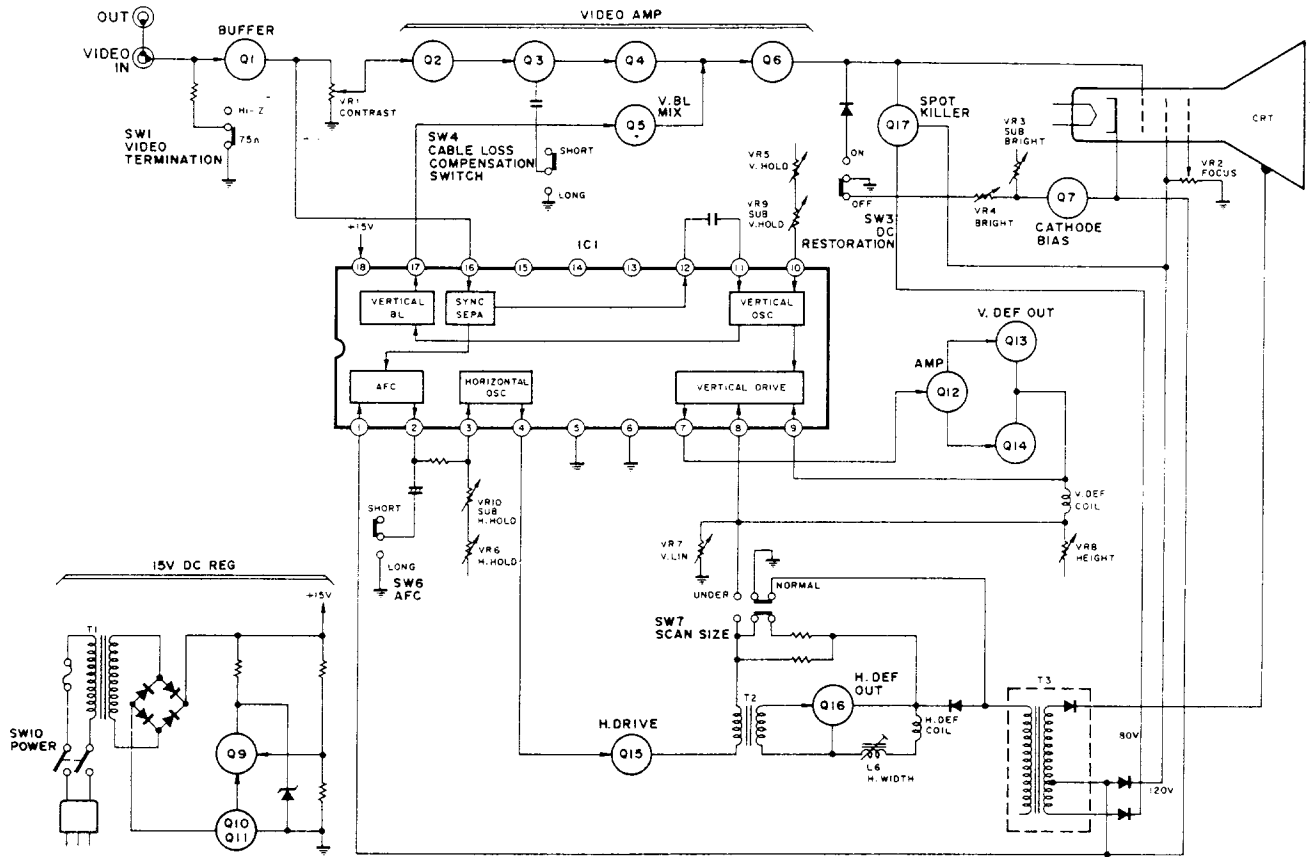
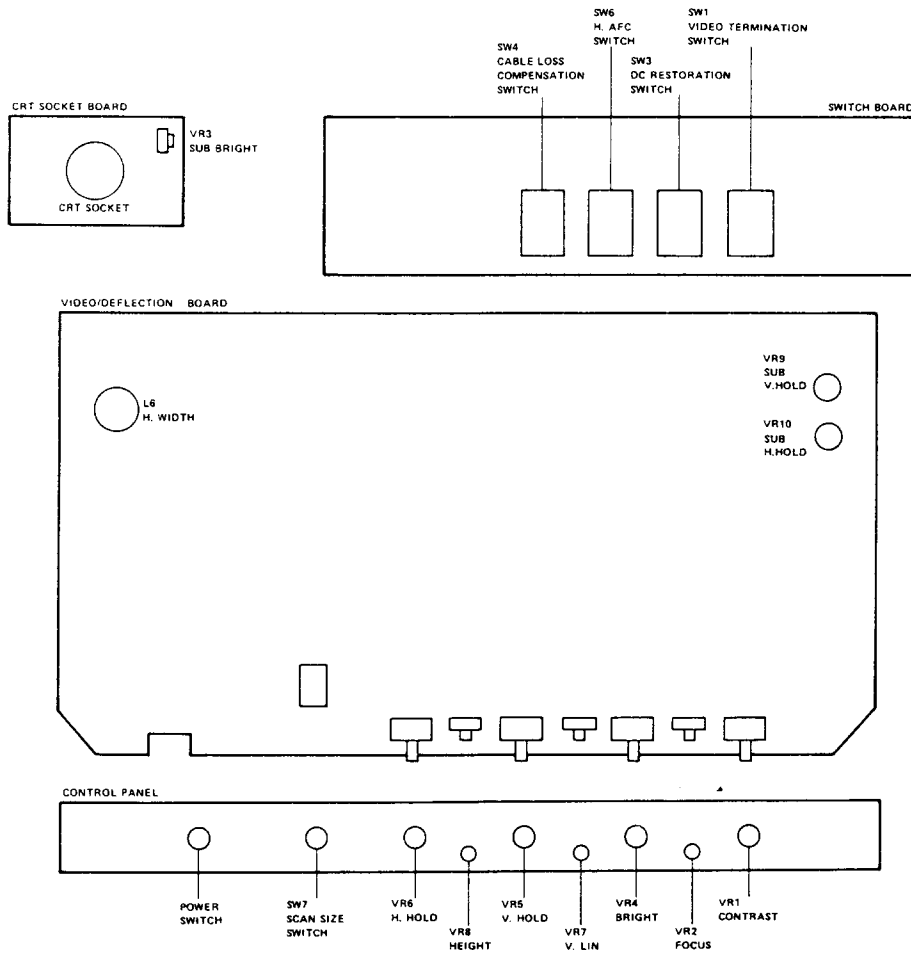

Fig. 6

# BLOCK DIAGRAM



## LOCATION OF ADJUSTING CONTROLS



# CONDUCTOR VIEW AND WII

SWITCH BOARD

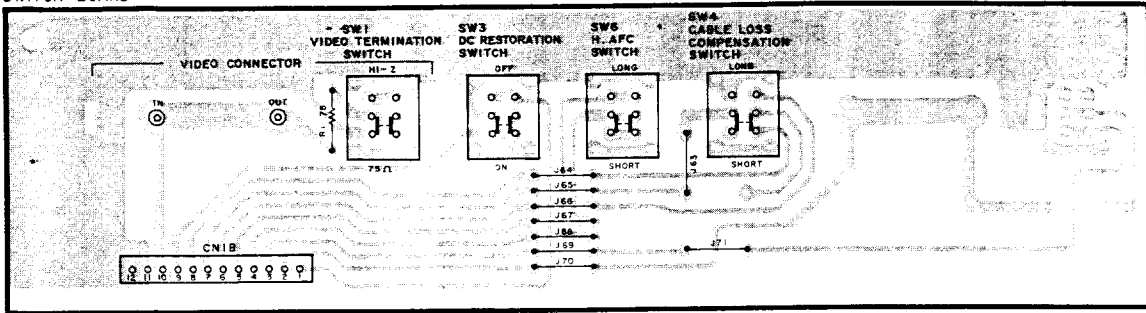

CRT SOCKET BOARD

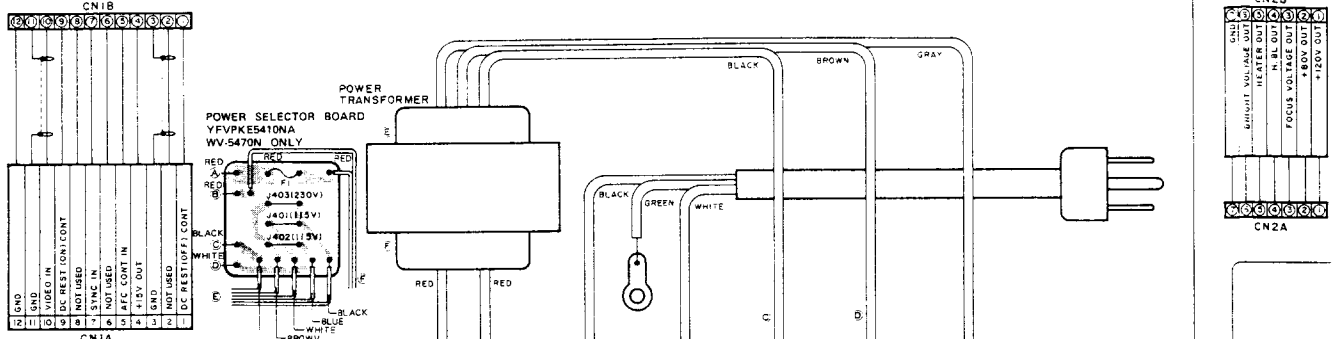
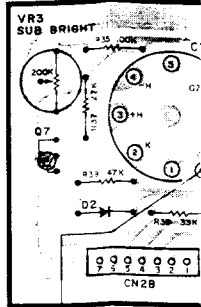

VIDEO/DEFLECTION BOARD

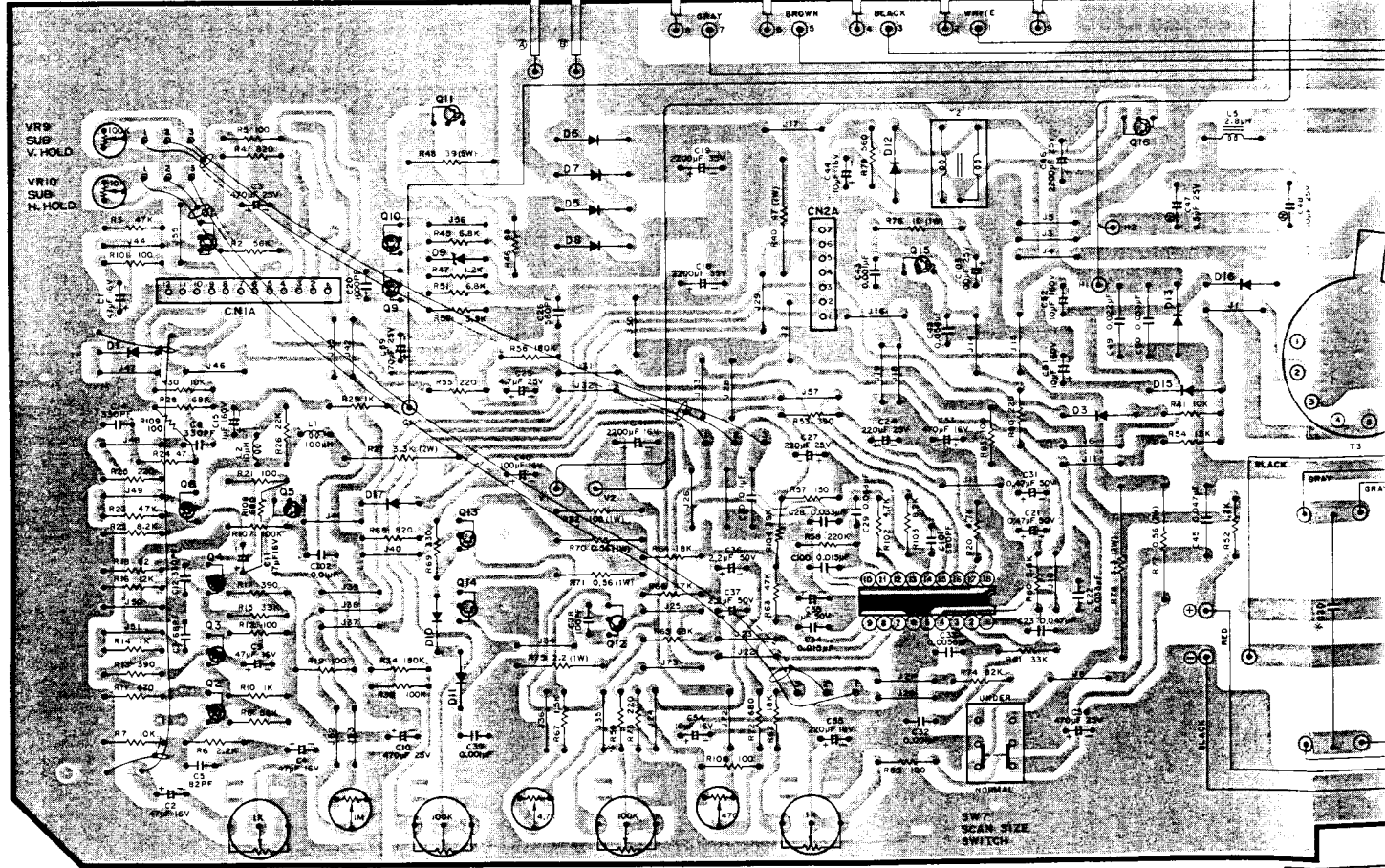

VR1	CONTRAST	VR2	FOCUS	VR4	BRIGHT	VR7	V.LIN	VR5	V.HOLD	R59	330K	VR8	HEIGHT	VR6	H.HOLD
										WV-5470E	270K				

WV-5470E	WV
MI-FUSE	JU

# AND WIRING DIAGRAM

KEY BOARD

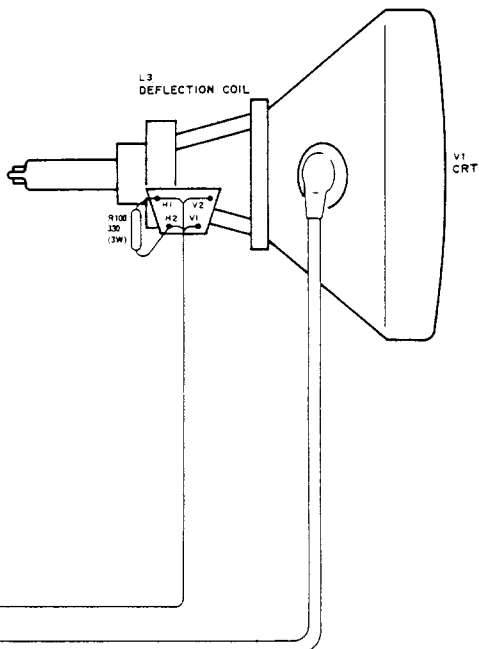
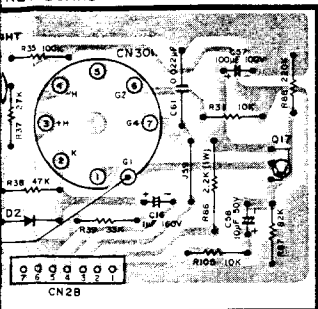

IC1	LA7820	A3
Q1	2SD636-RS	B1
Q2	2SD636-RS	A1
Q3	2SB641-RS	A1
Q4	2SD636-RS	A1
Q5	2SD636-RS	B1
Q6	2SC2258	B1
Q7	2SA685	D4
Q9	2SA564A-RS	B2
Q10	2SC828A-ST	B2
Q11	2SC1983-OY	C2
Q12	2SD636-RS	A2
Q13	2SC1226-QR	A2,B2
Q14	2SA699-QR	A2
Q15	2SC1567-RS	B3
Q16	2SD1163A	B4,C4
Q17	2SA685	D5
D1	OA91	B1
D2	YUDRU2M	D4
D3	YUDRU2M	B4
D4	LN21RPH	A5
D5	YWDR02Z	B2
D6	YWDR02Z	B2,C2
D7	YWDR02Z	B2
D8	YWDR02Z	B2
D9	YUDXZ090	B2
D10	MA150	A2
D11	MA150	A2
D12	YUDRU2M	B3,C3
D13	YUDRU2M	B4
D15	YUDRU2M	B4
D16	YUDRU2M	B4
D17	MA150	B2

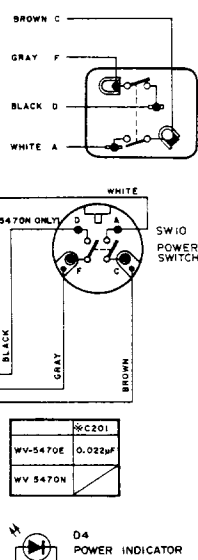
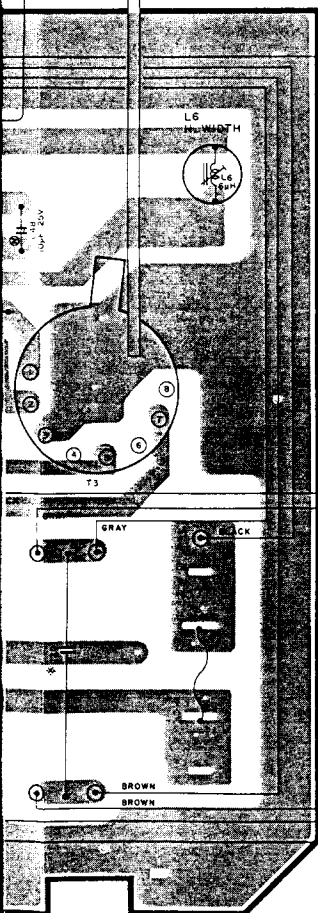

C201	
WV-5470E	0.022uF
WV-5470N	

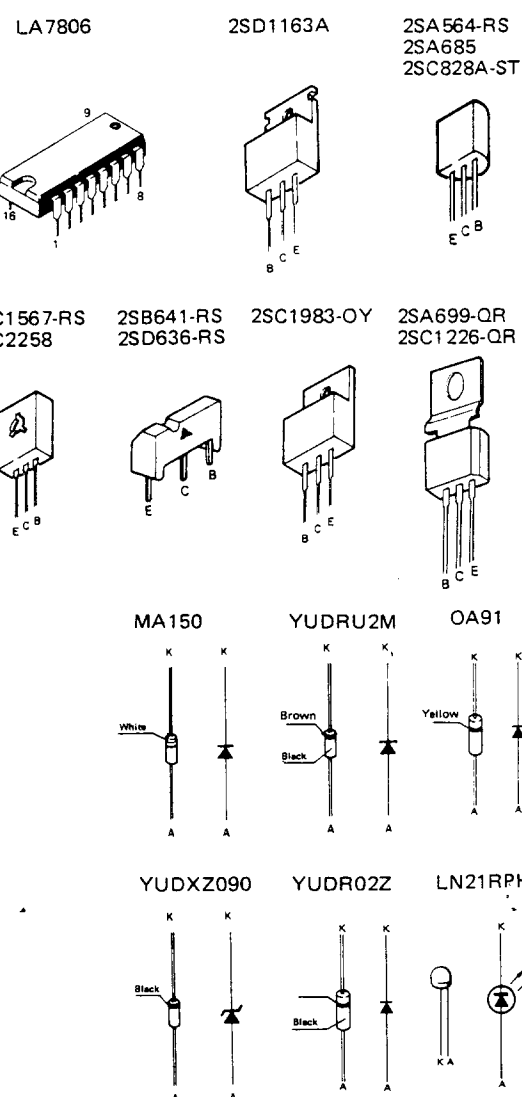
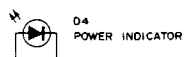



# CONDUCTOR VIEW AND WIRING DIAGRAM

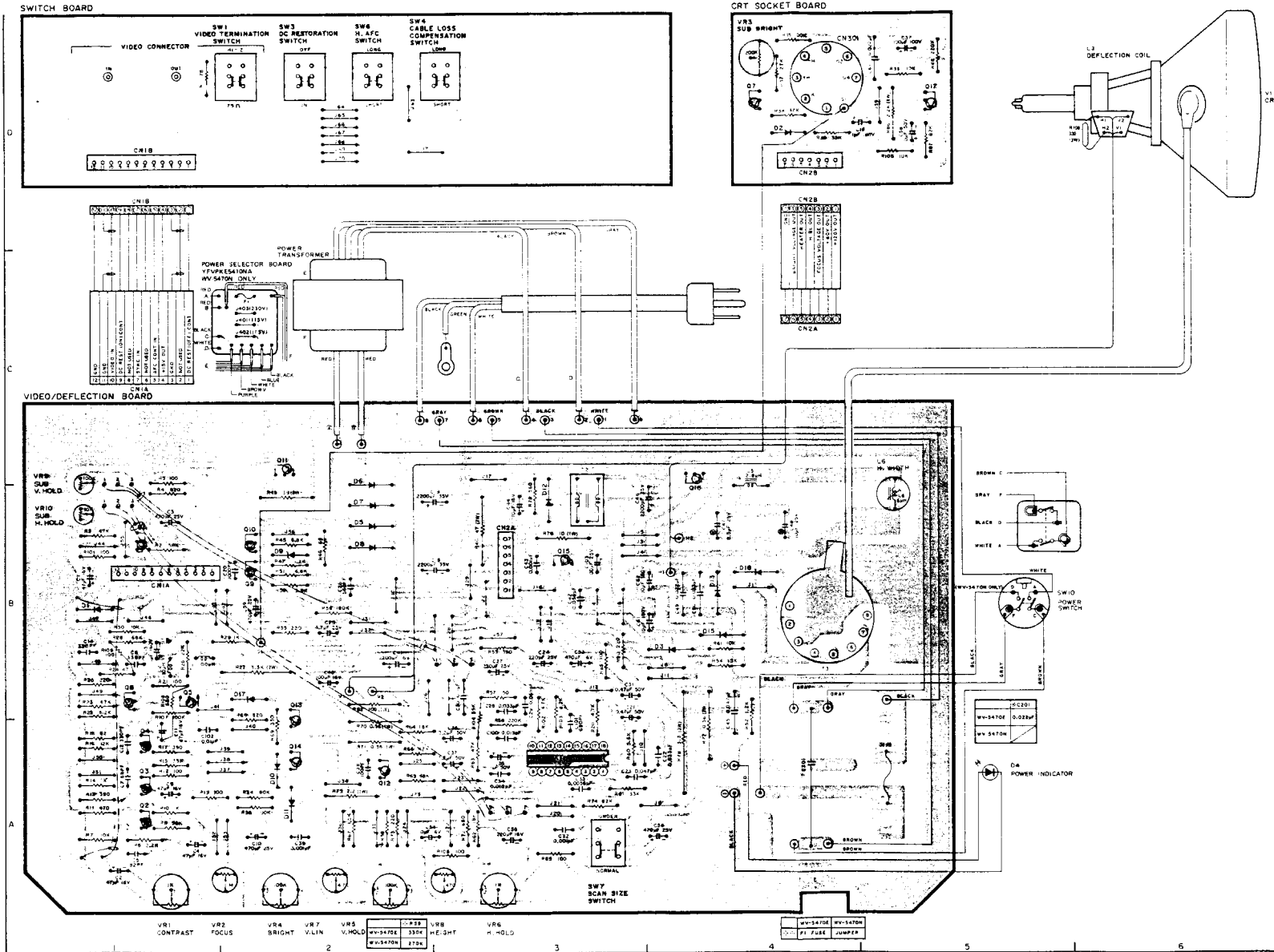

IC1	LA7820	A3
Q1	2SD636-RS	B1
Q2	2SD636-RS	A1
Q3	2SB641-RS	A1
Q4	2SD636-RS	A1
Q5	2SD636-RS	B1
Q6	2SC225B	B1
Q7	2SA685	D4
Q9	2SA564A-RS	B2
Q10	2SC828A-ST	B2
Q11	2SC1983-OY	C2
Q12	2SD636-RS	A2
Q13	2SC1226-QR	A2, B2
Q14	2SA699-QR	A2
Q15	2SC1567-RS	B3
Q16	2SD1163A	B4, C4
Q17	2SA685	D5
D1	OA91	B1
D2	YUDRU2M	D4
D3	YUDRU2M	B4
D4	LN21RPH	A5
D5	YWDR02Z	B2
D6	YWDR02Z	B2, C2
D7	YWDR02Z	B2
D8	YWDR02Z	B2
D9	YUDXZ090	B2
D10	MA150	A2
D11	MA150	A2
D12	YUDRU2M	B3, C3
D13	YUDRU2M	B4
D15	YUDRU2M	B4
D16	YUDRU2M	B4
D17	MA150	B2

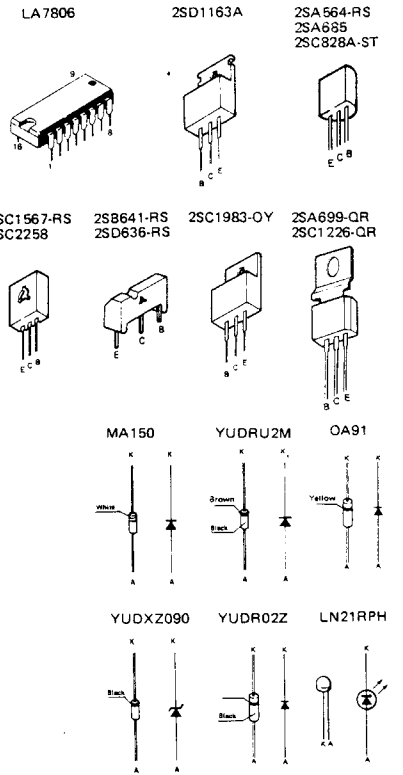

# SCHEMATIC DIAGRAM

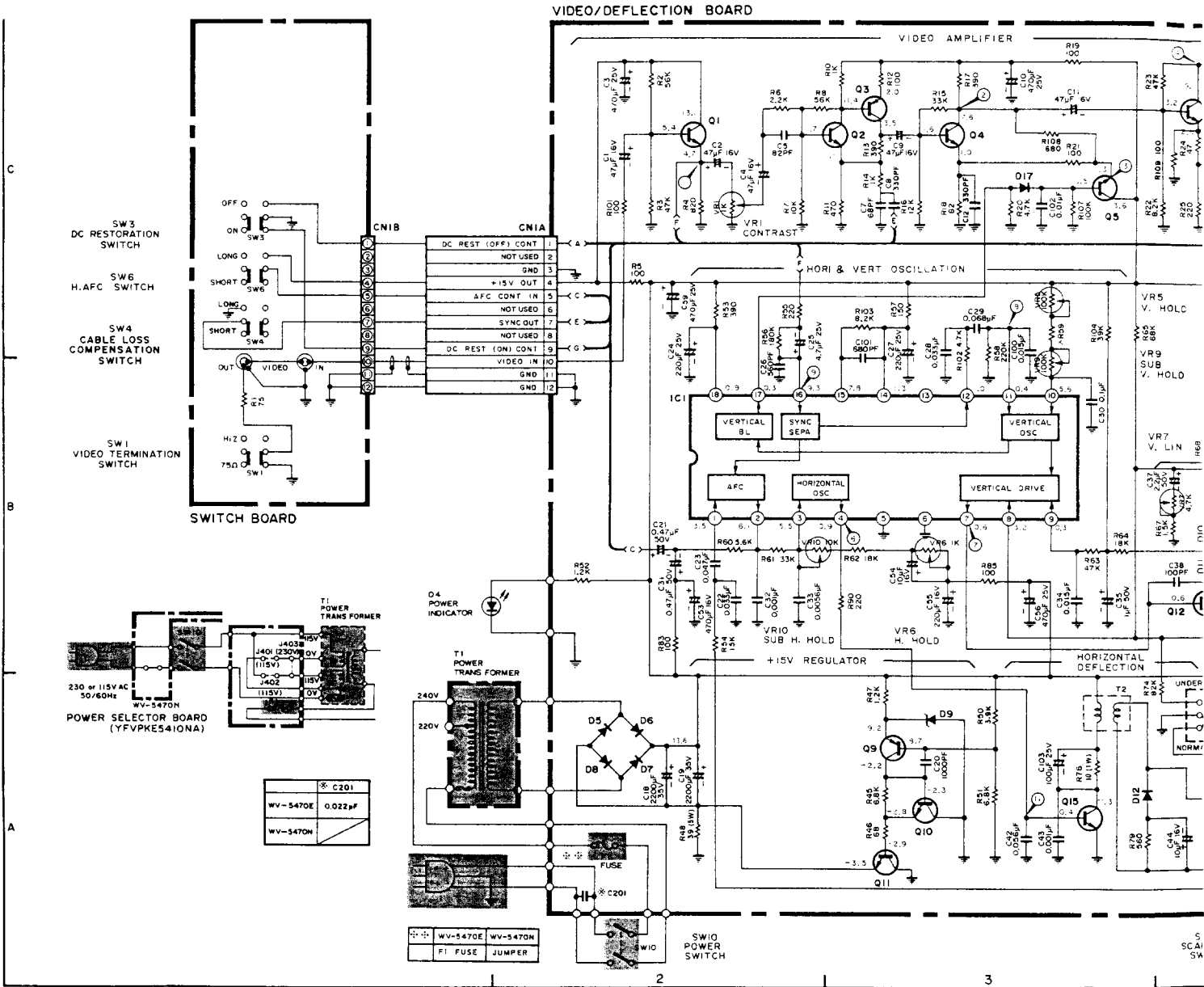

**PRODUCT SAFETY NOTE**

The shaded area on this schematic diagram incorporates special features important for protection from X-Radiation, fire and electrical shock hazards. When servicing it is essential that only manufacturer's specified parts be used for the critical components in the shaded areas of the schematic.

IC1	LA7820	B2,B3	Q12	2SD636-RS	E
Q1	2SD636-RS	C2	Q13	2SC1226-QR	E
Q2	2SD636-RS	C2,C3	Q14	2SA699-QR	B
Q3	2SB641-RS	C3	Q15	2SC1567-RS	A
Q4	2SD636-RS	C3	Q16	2SD1163A	A
Q5	2SD636-RS	C3	Q17	2SA685	C
Q6	2SC2258	C4	D1	OA91	C
Q7	2SA685	C5	D2	YUDRU2M	C
Q9	2SA564A-RS	A3	D3	YUDRU2M	A
Q10	2SC828A-ST	A3	D4	LN21RPH	B
Q11	2SC1983-QY	A3	D5	YWDR02Z	A

# SIGNAL WAVEFORMS

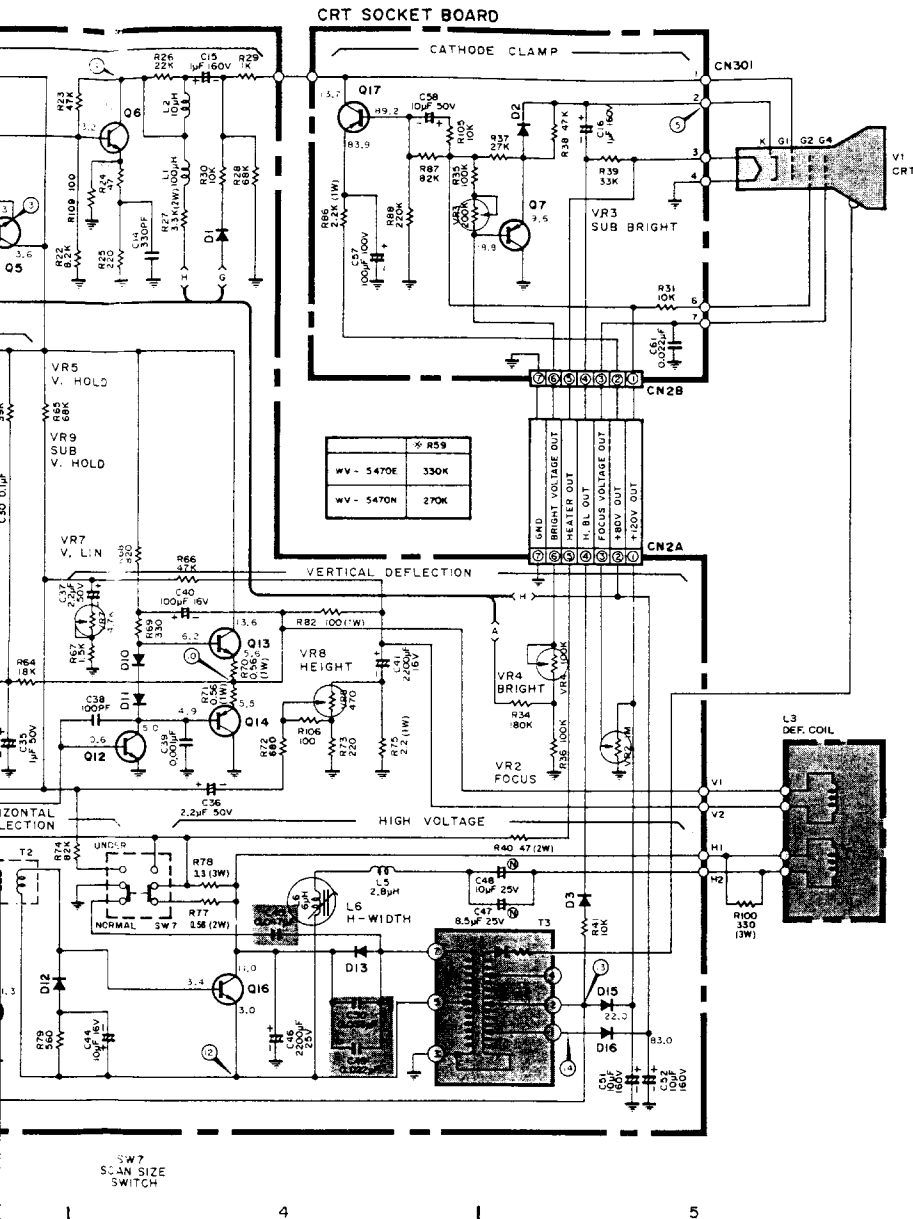

① 0.2V/DIV, 10μs/DIV

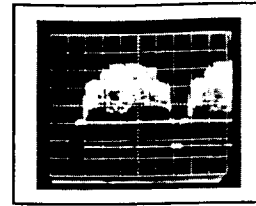

② 1V/DIV, 10μs/DIV

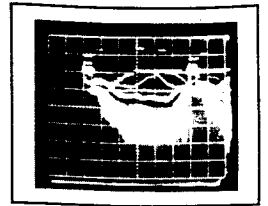

③ 1V/DIV, 5ms/DIV

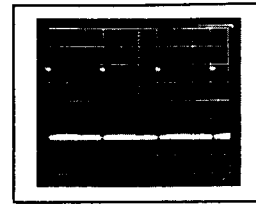

④ 10V/DIV, 10μs/DIV

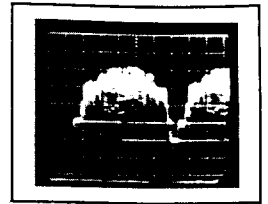

⑤ 20V/DIV, 10μs/DIV

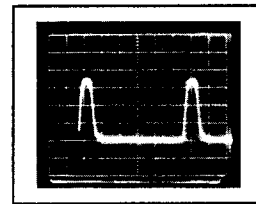

⑥ 0.5V/DIV, 10μs/DIV

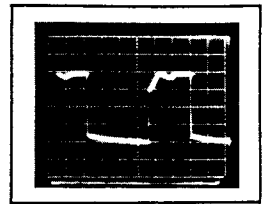

⑦ 0.2V/DIV, 2ms/DIV

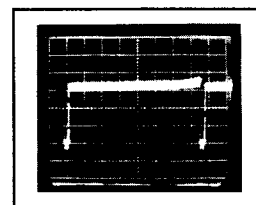

⑧ 0.5V/DIV, 5ms/DIV

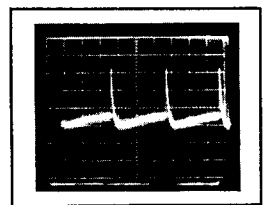

⑨ 0.2V/DIV, 10μs/DIV



⑩ 5V/DIV, 5ms/DIV

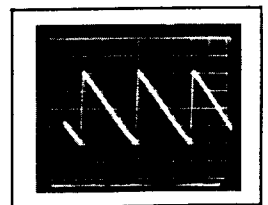

⑪ 0.2V/DIV, 10μs/DIV

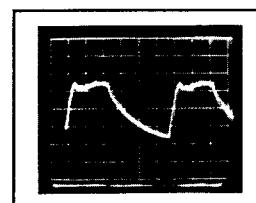

⑫ 20V/DIV, 10μs/DIV

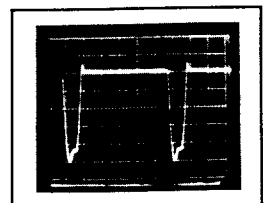

⑬ 50V/DIV, 10μs/DIV

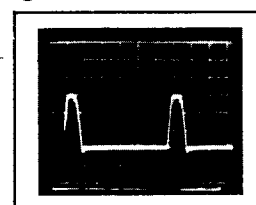

⑭ 20V/DIV, 10μs/DIV

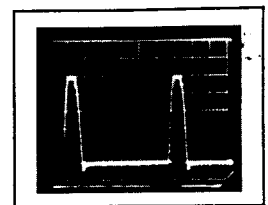

636-RS	B4	D6	YWDR02Z	A2
1226-QR	B4	D7	YWDR02Z	A2
699-QR	B4	D8	YWDR02Z	A2
1567-RS	A3	D9	YUDXZ090	A3
1163A	A4	D10	MA150	B4
685	C4	D11	MA150	B4
1	C4	D12	YUDRU2M	A3
DRU2M	C5	D13	YUDRU2M	A4
DRU2M	A5	D15	YUDRU2M	A5
1RPH	B1,B2	D16	YUDRU2M	A5
DR02Z	A2	D17	MA150	C3

# SCHEMATIC DIAGRAM

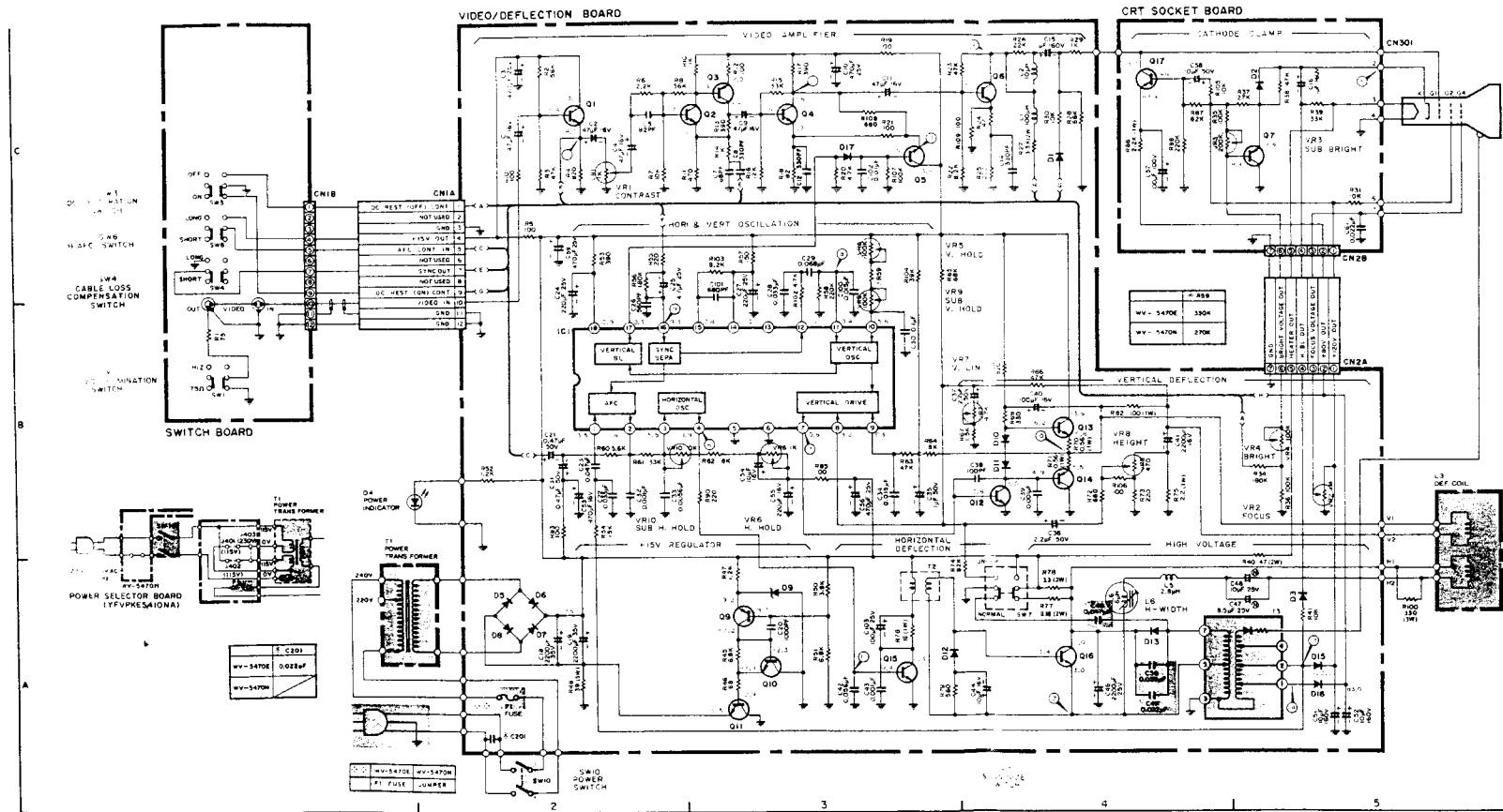

# SIGNAL WAVEFORMS

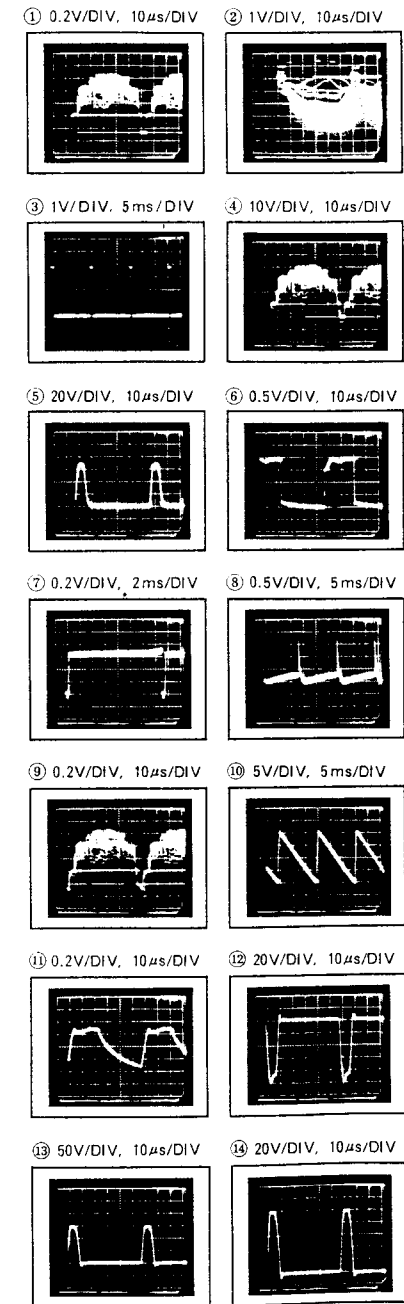

### PRODUCT SAFETY NOTE

The shaded area on this schematic diagram incorporates special features important for protection from X-Radiation, fire and electrical shock hazards. When servicing it is essential that only manufacturer's specified parts be used for the critical components in the shaded areas of the schematic.

IC1	LA7820	82,B3	Q12	2SD636-RS	34	D6	YWDR02Z	A2
Q1	2SD636-RS	C2	Q13	2SC1226-QR	B4	D7	YWDR02Z	A2
Q2	2SD636-RS	C2,C3	Q14	2SA639-QR	B4	D8	YWDR02Z	A2
Q3	2SB641-RS	C3	Q15	2SC1867-RS	A3	D9	YUDXZ090	A3
Q4	2SD636-RS	C3	Q16	2SD1163A	A4	D10	MA150	B4
Q5	2SD636-RS	C3	Q17	2SA685	C4	D11	MA150	B4
Q6	2SC2258	C4	D1	OA91	C4	D12	YUDRU2M	A3
Q7	2SA685	C5	D2	YUDRU2M	C5	D13	YUDRU2M	A4
Q8	2SA564A-RS	A3	D3	YUDRU2M	A5	D15	YUDRU2M	A5
Q10	2SC828A-ST	A3	D4	LN21RPH	B1,B2	D16	YUDRU2M	A5
Q11	2SC1983-OY	A3	D5	YWDR02Z	A2	D17	MA150	C3

# EXPLODED VIEW

- PCB001 YFVPKB5470EA
- PCB002 YFVPKC5470JA
- PCB003 YFVPKD5470PA
- PCB004 YFVPK5410NA
- V1 440CVB4
- L3 YFYS33145
- T1 YFPT66E004
- E1 YFPT66N010
- YWKPLTSA-8
- YWHBS-3-08
- YWCE0099-08F
- YWVM0099-08
- YW8NC-R
- CN1 YFV5BA0011A1
- M1 YFV5WA0092A3
- M2 YWV5350HR01
- M3 YWV5350HR02
- M4 YWV5350HR03A
- M5 YFV2CA0005A4
- M6 YFV2KA0042A3
- M8 YFV5EA0110A3
- M9 YFV4JA0039A4
- M10 YFV5KA0028A2
- M11 YFV5EA0109A2
- M12 YFV2KA0045A2
- M13 YFV2VA0001A4
- M14 YWS-WB02
- M15 YWSR6N6W-1
- M16 YWSR5N4
- M17 YFV7QA0200A4
- YFV7QA0201A4
- YFV7QA0199A4
- M18 YWS-CULRB08
- M19 YWV1000NUR2
- M20 YFV7MA0028A4
- M21 YFV7MA0029A4
- M22 YW8-NBT
- M23 YWS-XEGRB03A
- M24 YFV2CA0007A4
- M25 YFV7DA0003B4
- M26 YFV7DA0004A4
- M27 YVZC700RB50
- M28 YW-8-UR01A
- M40 YFV2KA0044A4
- M41 YFV2FA0043A4
- M42 YFV1KA0010A4
- M43 YFV2JA0003A4
- M44 YFV2JA0004A4
- M45 YFV6BA0010A2
- M46 YFV6AA0007A3

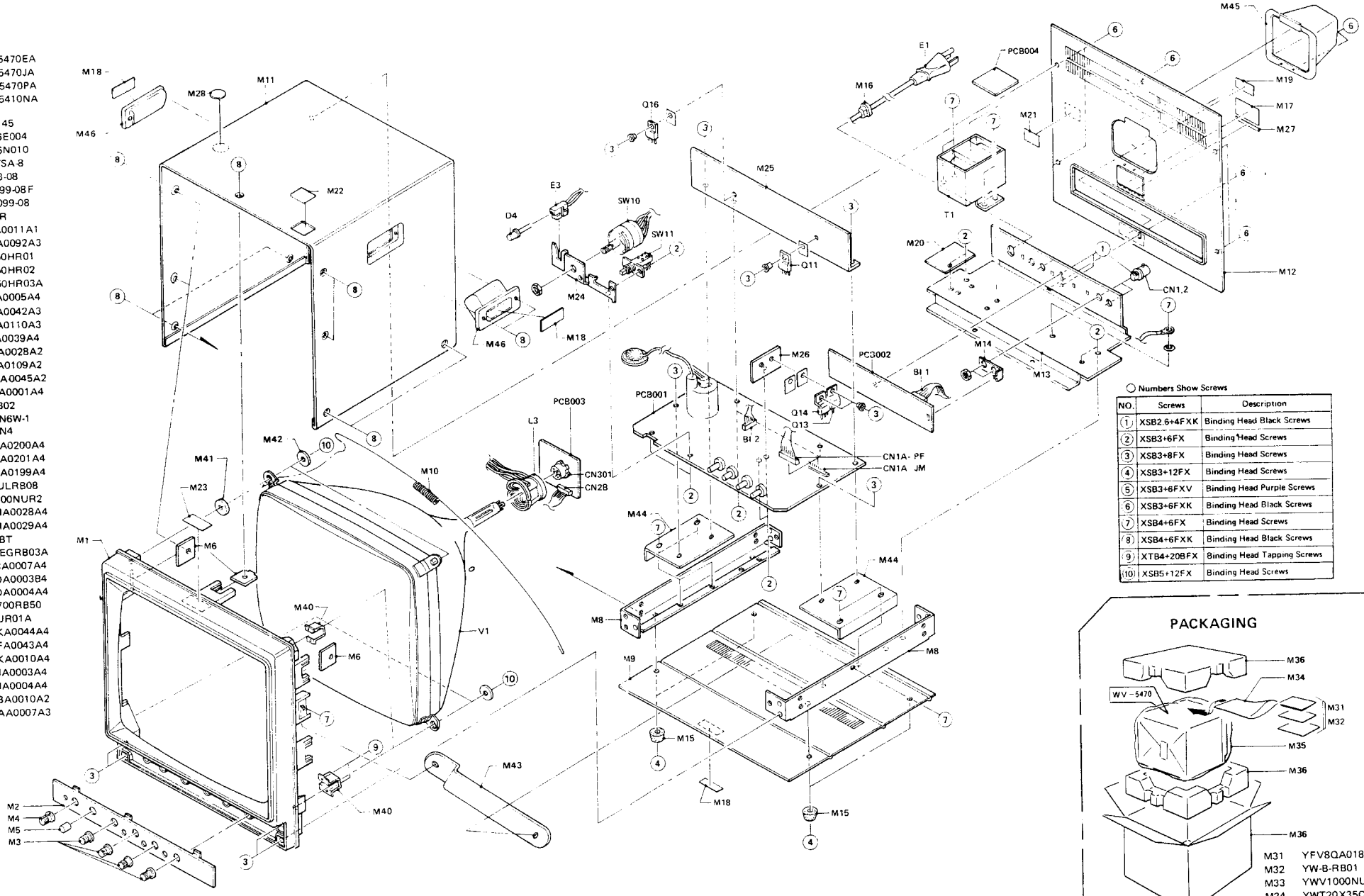

Numbers Show Screws

NO.	Screws	Description
①	XSB2.6+4FXK	Binding Head Black Screws
②	XSB3+6FX	Binding Head Screws
③	XSB3+8FX	Binding Head Screws
④	XSB3+12FX	Binding Head Screws
⑤	XSB3+6FXV	Binding Head Purple Screws
⑥	XSB3+6FXK	Binding Head Black Screws
⑦	XSB4+6FX	Binding Head Screws
⑧	XSB4+6FXK	Binding Head Black Screws
⑨	XTB4+208FX	Binding Head Tapping Screws
⑩	XSB5+12FX	Binding Head Screws

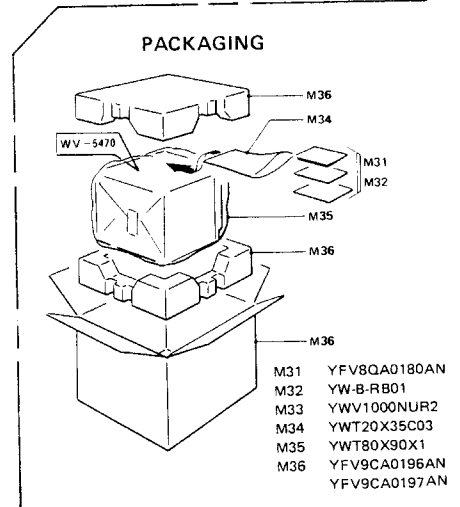

Important Notice

# REPLACEMENT PARTS LIST

- Components identified by  $\Delta$  mark have special characteristics important for safety. When replacing any of these components, use only manufacturer's specified parts.
- Components identified by \* mark are new parts used from this model.

MODEL WV-5470E/N

SYM-BOL NO.	PART NO.	DESCRIPTION	SYM-BOL NO.	PART NO.	DESCRIPTION
<b>WV-5470E/N MISCELLANEOUS</b>			<b>YFVPKB5470EA YFVPKB5470NA VIDEO/DEFLECTION BOARD</b>		
V1	$\Delta$ 440CVB4	Cathode Ray Tube	PCB001	* YFVPKB5470EA	Printed Circuit Board Assembly for WV-5470E
R100	ERG3ANJ331	Metal 330 $\Omega$ 3W		* YFVPKB5470NA	Printed Circuit Board Assembly for WV-5470N
L3	$\Delta$ YFYS33145	Deflection Coil Ass'y	IC1	LA7820	IC
T1	$\Delta$ YFPTE66E004	Power Transformer for WV-5470E	Q1, 2	2SD636-RS	Transistor
	YFPTE66N010	Power Transformer for WV-5470N	Q3	2SB641-RS	Transistor
E1	YWKPLTSA-8	AC Power Cord for WV-5470E/A	Q4, 5	2SD636-RS	Transistor
	YWHBS-3-08	AC Power Cord for WV-5470/B	Q6	2SC2258	Transistor
	YWCE0099-08F	AC Power Cord for WV-5470/C	Q9	2SA564A-RS	Transistor
	YWVM0099-08	AC Power Cord for WV-5470/G	Q10	2SC828A-ST	Transistor
CN1	YWBNC-R	BNC Connector	Q11	2SC1983-OY	Transistor
M1	* YFV5BA0011A1	Front Escutcheon	Q12	2SD636-RS	Transistor
M2	* YFV5WA0092A3	Operation Panel	Q13	2SC1226-QR	Transistor
M3	YWV5350HR01	Knob A (x4)	Q14	2SA699-QR	Transistor
M4	YWV5350HR02	Knob B	Q15	2SC1567-RS	Transistor
M5	YWV5350HR03A	Push Knob	Q16	2SD1163A	Transistor
M6	* YFV2CA0005A4	Nut Plate A (x5)	D1	QA91	Diode
M8	* YFV2KA0042A3	Mounting Bracket (x2)	D3	YUDRU2M	Diode
M9	* YFV5EA0110A3	Bottom Plate	D4	LN21RPH	LED
M10	* YFV4JA0039A4	CRT Ground Spring	D5~8	YWDR02Z	Diode
M11	* YFV5KA0028A2	Upper Cover	D9	YUDXZ090	Diode
M12	* YFV5EA0109A2	Rear Plate	D10, 11	MA150	Diode
M13	* YFV2KA0045A2	Rear Chassis	D12	YUDRU2M	Diode
M14	* YFV2VA0001A4	Ground Plate (x2)	D13	YUDRU2M	Diode
M15	YWS-WB02	Rubber Foot (x4)	D15, 16	YUDRU2M	Diode
M16	YWSR6N6W-1	Cord Clamp for 5470/E	D17	MA-150	Diode
	YWSR5N4	Cord Clamp for 5470/N	R2	ERD25FJ563	Carbon 56K $\Omega$ 1/4W
M17	* YFV7QA0200A4	Main Label for WV-5470E/A	R3	ERD25FJ473	Carbon 47K $\Omega$ 1/4W
	* YFV7QA0201A4	Main Label for WV-5470/BCG	R4	ERD25FJ821	Carbon 820 $\Omega$ 1/4W
	* YFV7QA0199A4	Main Label for WV-5470N	R5	ERD25FJ101	Carbon 100 $\Omega$ 1/4W
M18	YWS-CULRB08	Caution Label for WV-5470/E(x3)	R6	ERD25FJ222	Carbon 2.2K $\Omega$ 1/4W
M19	YWV1000NUR2	Voltage Label for WV-5470E/AC,N	R7	ERD25FJ103	Carbon 10K $\Omega$ 1/4W
M20	* YFV7MA0028A4	High Voltage Fuse Label	R8	ERD25FJ563	Carbon 56K $\Omega$ 1/4W
M21	* YFV7MA0029A4	Serviceman Label for WV-5470/G	R10	ERD25FJ102	Carbon 1K $\Omega$ 1/4W
M22	YW8-NBT	National Label	R11	ERD25FJ471	Carbon 470 $\Omega$ 1/4W
M23	YWS-XEGRB03A	X-Lay Label for WV-5470/BCG	R12	ERD25FJ101	Carbon 100 $\Omega$ 1/4W
M27	YVZC700RB50	Serial No. Label	R13	ERD25FJ391	Carbon 390 $\Omega$ 1/4W
M28	YW-B-UR01A	Made in Japan Label for WV-5470/B	R14	ERD25FJ102	Carbon 1K $\Omega$ 1/4W
M40	YFV2KA0044A4	Mounting Angle for CRT	R15	ERD25FJ333	Carbon 33K $\Omega$ 1/4W
M41	YFV2FA0043A4	CRT Cushion	R16	ERD25FJ123	Carbon 12K $\Omega$ 1/4W
M42	YFV1KA0010A4	Washer	R17	ERD25FJ391	Carbon 390 $\Omega$ 1/4W
M43	YFV2JA0003A4	Support Bracket for CRT	R18	ERD25FJ820	Carbon 82 $\Omega$ 1/4W
M44	YFV2JA0004A4	Mounting Angle for Circuit Board (x2)	R19	ERD25FJ101	Carbon 100 $\Omega$ 1/4W
M45	YFV6BA0010A2	Rear Cover for CRT	R20	ERD25FJ472	Carbon 4.7K $\Omega$ 1/4W
M46	YFV6AA0007A3	Handle for Upper Cover	R21	ERD25FJ101	Carbon 100 $\Omega$ 1/4W
			R22	ERD25FJ822	Carbon 8.2K $\Omega$ 1/4W
			R23	ERD25FJ473	Carbon 47K $\Omega$ 1/4W

SYM-BOL NO.	PART NO.	DESCRIPTION	SYM-BOL NO.	PART NO.	DESCRIPTION
R24	ERD25FJ470	Carbon 47Ω 1/4W	VR1	EVHOTAS20B13	Variable Resistor 1KΩ
R25	ERD25FJ221	Carbon 220Ω 1/4W	VR2	SR29D1MB	Variable Resistor 1MΩ
R26	ERD25FJ223	Carbon 22KΩ 1/4W	VR4, 5	EVHOTAS20B15	Variable Resistor 100KΩ
R27	ERG2ANJ332	Metal 3.3KΩ 2W	VR6	EVHOTAS20B13	Variable Resistor 1KΩ
R28	ERD25FJ683	Carbon 68KΩ 1/4W	VR7	YFSR29D4R7KB	Variable Resistor 4.7KΩ
R29	ERD25FJ102	Carbon 1KΩ 1/4W	VR8	YWSR29D470B	Variable Resistor 470Ω
R30	ERD25FJ103	Carbon 10KΩ 1/4W	VR9	YWH0651A100K	Variable Resistor 100KΩ
R34	ERD25FJ184	Carbon 180KΩ 1/4W	VR10	YWH0651A10K	Variable Resistor 10KΩ
R36	ERD25FJ104	Carbon 100KΩ 1/4W	C1, 2	ECEA1CS470	Electrolytic 47μF 16V
R40	ERG2ANJ470	Metal 47Ω 2W	C3	ECEA1ES471	Electrolytic 470μF 25V
R41	ERD25FJ103	Carbon 10KΩ 1/4W	C4	ECEA1CS470	Electrolytic 47μF 16V
R45	ERD25FJ682	Carbon 6.8KΩ 1/4W	C5	ECCR1H820J	Ceramic 82pF 50V
R46	ERD25FJ680	Carbon 68Ω 1/4W	C7	EUR1H680	Ceramic 68pF 50V
R47	ERD25FJ122	Carbon 1.2KΩ 1/4W	C8	ECKW/H331KB	Ceramic 330pF 50V
R48	ERF5ZJ390	Wire Wound 39Ω 5W	C9	ECEA1CS470	Electrolytic 47μF 16V
R50	ERO25CKF3901	Metal 3.9kΩ 1/4W	C10	ECEA1ES471	Electrolytic 470μF 25V
R51	ERO25CKF6801	Metal 6.8KΩ 1/4W	C11	ECEA1CS470	Electrolytic 47μF 16V
R52	ERD25FJ122	Carbon 1.2KΩ 1/4W	C12	ECKR1H331KB	Ceramic 330pF 50V
R53	ERD25FJ391	Carbon 390Ω 1/4W	C14	ECKR1H331KB	Ceramic 330pF 50V
R54	ERD25FJ153	Carbon 15KΩ 1/4W	C15	ECEA2CS010	Electrolytic 1μF 100V
R55	ERD25FJ221	Carbon 220Ω 1/4W	C18, 19	ECEA1VS222E	Electrolytic 2200pF 35V
R56	ERD25FJ184	Carbon 180KΩ 1/4W	C20	ECKR1H102KB	Ceramic 1000pF 50V
R57	ERD25FJ151	Carbon 150Ω 1/4W	C21	ECEA1HSR47	Electrolytic 0.47μF 50V
R58	ERD25FJ224	Carbon 220KΩ 1/4W	C22	ECQV05333JZ	Plastic 0.033μF 50V
R59	ERD25FJ334	Carbon 330kΩ 1/4W for WV-5470E	C23	ECQV05473JZ	Plastic 0.047μF 50V
R59	ERD25FJ274	Carbon 270Ω 1/4W for WV-5470N	C24	ECEA1ES221	Electrolytic 220μF 25V
R60	ERD25FJ562	Carbon 5.6KΩ 1/4W	C25	ECEA1ES4R7	Electrolytic 4.7μF 25V
R61	ERD25FJ333	Carbon 33KΩ 1/4W	C26	ECCR1H561J	Ceramic 560pF 50V
R62	ERD25FJ183	Carbon 18KΩ 1/4W	C27	ECEA1ES221	Electrolytic 220μF 25V
R63	ERD25FJ473	Carbon 47KΩ 1/4W	C28	ECQV05333JZ	Plastic 0.033μF 50V
R64	ERD25FJ183	Carbon 18KΩ 1/4W	C29	ECQV05683JZ	Plastic 0.068μF 50V
R65	ERD25FJ683	Carbon 68KΩ 1/4W	C30	ECQV05104J	Plastic 0.10μF 50V
R66	ERD25FJ473	Carbon 47KΩ 1/4W	C31	ECEA1HSR47	Electrolytic 0.47μF 50V
R67	ERD25FJ152	Carbon 1.5KΩ 1/4W	C32	ECQP1102JZ	Plastic 1000pF 100V
R68	ERD25FJ821	Carbon 820Ω 1/4W	C33	ECQP1562JZ	Plastic 5600pF 100V
R69	ERD25FJ331	Carbon 330Ω 1/4W	C34	ECQV05153JZ	Plastic 0.015μF 50V
R70, 71	ERX1ANJR56	Metal 0.56Ω 1W	C35	ECEA50V1T	Electrolytic 1μF 50V
R72	ERD25FJ681	Carbon 680Ω 1/4W	C36	ECEA50V2R2T	Electrolytic 2.2μF 50V
R73	ERD25FJ221	Carbon 220Ω 1/4W	C37	ECEA1HS2R2	Electrolytic 2.2μF 50V
R74	ERD25FJ823	Carbon 82KΩ 1/4W	C38	ECKR1H101KB	Ceramic 100pF 50V
R75	ERX1ANJ2R2	Metal 2.2Ω 1W	C39	ECQP1102JZ	Plastic 1000pF 100V
R76	ERG1ANJ100H	Metal 10Ω 1W	C40	ECEA1CS101	Electrolytic 100μF 16V
R77	ERX2ANJR56	Metal 0.56Ω 2W	C41	ECEA1CS222	Electrolytic 2200μF 16V
R78	ERX3ANJ3R3H	Metal 3.3Ω 3W	C42	ECQV05563J	Plastic 0.056μF 100V
R79	ERD25FJ561	Carbon 560Ω 1/4W	C43	ECQP1102JZ	Plastic 1000pF 50V
R82	ERG1ANJ101	Metal 100Ω 1W	C44	ECEA1CS100	Electrolytic 10μF 16V
R83, 85	ERD25FJ101	Carbon 100Ω 1/4W	C45	△ ECQM2473KZ	Plastic 0.047μF 200V
R90	ERD25FJ221	Carbon 220Ω 1/4W	C46	ECEA1ES222E	Electrolytic 2200μF 25V
R101	ERD25FJ101	Carbon 100Ω 1/4W	C47	ECEA25W8R5Z	Electrolytic 8.5μF 25V
R102	ERD25FJ472	Carbon 4.7KΩ 1/4W	C48	ECEA25W10Z	Electrolytic 10μF 25V
R103	ERD25FJ822	Carbon 8.2KΩ 1/4W	C49	△ ECQM2223KZ	Plastic 0.022μF 200V
R104	ERD25FJ393	Carbon 39KΩ 1/4W	C50	△ ECQM2333KZ	Plastic 0.033μF 200V
R106	ERD25FJ101	Carbon 100Ω 1/4W	C51, 52	ECEA2CS100E	Electrolytic 10μF 100V
R107	ERD25FJ104	Carbon 100KΩ 1/4W	C53	ECEA1CS471	Electrolytic 470μF 16V
R108	ERD25FJ681	Carbon 680Ω 1/4W	C54	ECEA1CS100	Electrolytic 10μF 16V
R109	ERD25FJ101	Carbon 100Ω 1/4W	C55	ECEA1CS221	Electrolytic 220μF 16V
			C56	ECEA1ES471	Electrolytic 470μF 25V

SYM-BOL NO.	PART NO.	DESCRIPTION	SYM-BOL NO.	PART NO.	DESCRIPTION
C59	ECEA1ES471	Electrolytic 470 $\mu$ F 25V	<b>YFVPKE5410NA POWER SELECTOR BOARD</b>		
C100	ECQV05153JZ	Plastic 0.015 $\mu$ F 50V			
C101	ECKR1H681KB	Plastic 680pF 50V	PCB004 *	YFVPKE5410NA	Printed Circuit Board Assembly
C102	ECKR1H103KB	Ceramic 0.01 $\mu$ F 50V	F1	YWST6-3A	3A Fuse
C103	ECEA1ES101	Electrolytic 100 $\mu$ F 25V	E2	YWSN5051	Fuse Holder
C201	ECN-C4A223M	Plastic 0.022 $\mu$ F 400V for WV-5470E	E3	YWTM028	Terminal
L1	YWFL5H-101K	Coil 100 $\mu$ H	<b>ACCESSORY PARTS/PACKAGING PARTS</b>		
L2	YWFL5H100K	Coil 10 $\mu$ H			
L5	YFTLH2R8L	Coil 2.8 $\mu$ H	M31	YFV8QA0180AN	Operating Instructions
L6	YFTLH6R0W	Coil 6 $\mu$ H	M32	YW-B-RB01	Warranty Card for WV-5470/B
T2	YFTLH3412K	H. Drive Transformer	M33	YWV1000NUR2	Voltage Label for WV-5470N
T3	ETF35L29V	Flyback Transformer	M34	YWT20X35C03	Polyethylene Bag for Operating Instructions or Power Card
SW10	EVQB08K20	Power Switch	M35	YWT80X90X1	Polyethylene Bag for Monitor TV
SW11	YW1F01AC312	Scan Size Switch	M36	YFV9CA0196AN	Packaging Case for WV-5470/AC,N
F1	YFTS400MA	1A Fuse for WV-5470E		YFV9CA0197AN	Packaging Case for WV-5470/BCG
E2	YWSN5053	Fuse Holder (x2) for WV-5470E			
E3	YFSN005001	LED Holder			
CN1A-JM	EMCS1252M	12 pin Jack Male			
CN1A-PF	EMCM1230B32V	12 pin Connecting Wire Ass'y for CN1A and CN1B			
BI 2	EMCL0730D35V	7 pin Connecting Wire Ass'y for CN2A and CN2B			
M24	YFV2CA0007A4	Mounting Bracket for Switch			
M25	YFV7DA0003B4	Heat Sink A			
M26	YFV7DA0004A4	Heat Sink B			
<b>YFVPKC5470JA SWITCH BOARD</b>					
PCB002 *	YFVPKC5470JA	Printed Circuit Board Assembly			
R1,	ERD25FJ750	Carbon 75 $\Omega$ 1/4W			
SW1,3,4,6	YWSSC-322A	Slide Switch			
BI 1	EMCM1230B32V	12 Pin Connecting Wire Ass'y for BI1 and CN1A			
<b>YFVPKD5470PA CRT SOCKET BOARD</b>					
PCB003 *	YFVPKD5470PA	Printed Circuit Board Assembly			
Q7, 17	2SA685	Transistor			
D2	YUDRU2M	Diode			
R31	ERD25FJ103	Carbon 10K $\Omega$ 1/4W			
R35	ERD25FJ104	Carbon 100K $\Omega$ 1/4W			
R37	ERD25FJ273	Carbon 27K $\Omega$ 1/4W			
R38	ERD25FJ473	Carbon 47K $\Omega$ 1/4W			
R39	ERD25FJ333	Carbon 33K $\Omega$ 1/4W			
R86	ERG1ANJ222	Metal 2.2K $\Omega$ 1W			
R87	ERD25FJ823	Carbon 82K $\Omega$ 1/4W			
R88	ERD25FJ224	Carbon 220K $\Omega$ 1/4W			
R105	ERD25FJ103	Carbon 10K $\Omega$ 1/4W			
VR3	EVL50AA00B25	Variable Resistor 200K $\Omega$			
C16	ECEA2CS010	Electrolytic 1 $\mu$ F 100V			
C57	ECEA2AS101	Electrolytic 100 $\mu$ F 100V			
C58	ECEA1HS100	Electrolytic 10 $\mu$ F 50V			
C61	ECQM2223KZ	Plastic Capacitor 0.022 $\mu$ F 200V			
CN301	YWTJS25640V	Socket			
CN2B	EMCL0730D35V	7 pin connecting wire Ass'y for CN2B and CN2A			