

Trinitron[®] ***Color Video Monitor***

Operating Instructions

Before operating the unit, please read this manual thoroughly and retain it for future reference.

 **Trinitron**
Multiformat

PVM-D14L5A

PVM-D20L5A

Owner's Record

The model and serial numbers are located at the rear. Record these numbers in the spaces provided below. Refer to these numbers whenever you call upon your Sony dealer regarding this product.

Model No. _____

Serial No. _____

WARNING

To prevent fire or shock hazard, do not expose the unit to rain or moisture.

Dangerously high voltage are present inside the unit.

Do not open the cabinet. Refer servicing to qualified personnel only.

In the event of a malfunction or when maintenance is necessary, consult an authorized Sony dealer.

ATTENTION – When the product is installed in a rack:

a) Elevated operating ambient temperature

If installed in a closed or multi-unit rack assembly, the operating ambient temperature of the rack environment may be greater than room ambient. Therefore, consideration should be given to installing the equipment in an environment compatible with the manufacture's maximum rated ambient temperature (T_{mra}: 0°C to 35°C (32°F to 95°F)).

b) Reduced air flow

Installation of the equipment in a rack should be such that the amount of air flow required for safe operation of the equipment is not compromised.

c) Mechanical loading

Mounting of the equipment in the rack should be such that a hazardous condition is not achieved due to uneven mechanical loading.

d) Circuit overloading

Consideration should be given to the connection of the equipment to the supply circuit and the effect that overloading of circuits might have on overcurrent protection and supply wiring. Appropriate consideration of equipment nameplate ratings should be used when addressing this concern.

e) Reliable earthing

Reliable earthing of rack-mounted equipment should be maintained. Particular attention should be given to supply connections other than direct connections to the branch circuit (e.g., use of power strips).

f) Gap keeping

Upper and lower gap of rack-mounted equipment should be kept 44 mm (1 3/4 inches).

Precaution

On safety

- Operate the unit only with a power source as specified in “Specifications” section.
- The nameplate indicating operating voltage, power consumption, etc., is located at the rear.
- Should any solid object or liquid fall into the cabinet, unplug the unit and have it checked by qualified personnel before operating it any further.
- Do not drop or place heavy objects on the power cord. If the power cord is damaged, turn off the power immediately. It is dangerous to use the unit with a damaged power cord.
- Unplug the unit from the wall outlet if it is not to be used for several days or more.
- Disconnect the power cord from the AC outlet by grasping the plug, not by pulling the cord.
- The socket-outlet shall be installed near the equipment and shall be easily accessible.

On installation

- Allow adequate air circulation to prevent internal heat build-up.
Do not place the unit on surfaces (rugs, blankets, etc.) or near materials (curtains, draperies) that may block the ventilation holes.
- Do not install the unit in a location near heat sources such as radiators or air ducts, or in a place subject to direct sunlight, excessive dust, mechanical vibration or shock.

On cleaning of the CRT surface

- The surface of the CRT has an optional PET film treatment.
Clean the CRT surface using the following method to avoid damaging the surface.
- Clean the CRT with a soft cloth.
When the CRT is dirtied with oily hands or fingerprints, clean it with a soft cloth moistened with a mild detergent solution.
- Never use abrasive cleansers, alkaline soap, strong solvents such as alcohol, thinner or benzine, since they will damage the surface.
- Do not rub the surface of the CRT with a solid object or hit it.

On cleaning

To keep the unit looking brand-new, periodically clean it with a mild detergent solution. Never use strong solvents such as thinner or benzine, or abrasive cleansers since they will damage the cabinet. As a safety precaution, unplug the unit before cleaning it.

On repacking

Do not throw away the carton and packing materials. They make an ideal container which to transport the unit. When shipping the unit to another location, repack it as illustrated on the carton.

If you have any questions about this unit, contact your authorized Sony dealer.

Table of contents

Precaution	3
Features	5
Connections	7
How to Connect the AC Power Cord	7
How to Connect a Cable to a BNC Connector	7
Location and Function of Parts and Controls	8
Control Panels	8
Rear Panel	10
Selecting the Menu Language	13
Using the Menu	14
Display List	15
STATUS Menu	17
COLOR TEMP/BAL Menu	17
USER CONTROL 1/2, 2/2 Menu	18
USER CONFIG 1/2, 2/2 Menu	19
REMOTE 1/2 PARALLEL Menu	20
REMOTE 2/2 SERIAL Menu	20
OPTION CONFIG Menu	21
KEY PROTECT Menu	22
Troubleshooting	22
Specifications	23

The explanation given in this manual can be applied to the following models unless noted otherwise.

When explanation differs among models, this is clearly indicated in this manual.

- PVM-D14L5A (14-inch monitor)
- PVM-D20L5A (20-inch monitor)

Illustrations of the video monitor are of the PVM-D14L5A.

Features

The PVM-D14L5A/PVM-D20L5A is a Trinitron color video monitor for professional use.

Picture

HR (High Resolution) Trinitron¹⁾ picture tube

HR Trinitron tube provides a high resolution picture. Horizontal resolution is more than 800 TV lines at the center of the picture.

Comb filter

When NTSC video signals are received, a comb filter activates to make more accurate Y/C separation. This contributes to less of a decrease in resolution, cross color and cross luminance phenomena.

Beam current feedback circuit

The built-in beam current feedback circuit assures stable white balance.

Two color system available

The monitor can display NTSC and PAL signals. The appropriate color system is selected automatically.

Auto chroma phase function

The chroma and phase of the decoder are automatically adjusted with the auto chroma phase function.

Blue only mode

In the blue only mode, an apparent monochrome display is obtained with all three of the R/G/B cathodes driven with a blue signal. This facilitates color saturation and phase adjustments and observation of VCR noise.

Input

Analog RGB/component input connectors

Analog RGB or component (Y, R-Y and B-Y) signals from video equipment can be input through these connectors. Select either of two signals using the RGB/COMP input switch button.

Y/C input connectors (S-input connector)

The video signal, split into the luminance signal (Y) and the chrominance signal (C), can be input through this connector, eliminating the interference between the two signals, which tends to occur in a composite video signal, ensuring video quality.

Expandable input capability

You can easily expand the input capability by installing an input adaptor (not supplied) in the input option slot in the rear of the monitor.

External sync input

When the EXT SYNC selector is in the on position, the monitor can be operated on the sync signal supplied from an external sync generator.

Automatic termination (connector with mark only)

The input connector is terminated at 75 ohms inside when nothing has been connected to the output connector. If a cable is connected to the output connector, the internal terminal is automatically released and the signals input to the input connector are output to the output connector (loop-through).

Functions

Multiformat

The monitor supports the principal formats (480I/480P/720P/1080I) for digital broadcasts as well as conventional NTSC and PAL color systems — a wide variety of signals whose horizontal frequency is between 15 kHz and 45 kHz.

Underscan mode

The signal normally scanned outside of the screen can be monitored in the underscan mode.

Note

When the monitor is in the underscan mode, the dark RGB scanning lines may appear on the top edge of the screen. These are caused by an internal test signal, rather than the input signal.

Horizontal/vertical delay mode

The horizontal and vertical sync signals can be monitored simultaneously in the H/V delay mode.

1) "Trinitron" is a registered trademark of Sony Corporation.

Features

Internal Caption Vision (Closed Caption) Decoder

When the image signals with caption vision signals are input, the English subtitles are superimposed and displayed on the screen. You can select the caption ON/OFF and the caption type in the menu.

Auto/manual degaussing

The CRT is automatically degaussed when the power is turned on. You can manually degauss the CRT by pressing the DEGAUSS button.

In the menu, you can set the time to automatically degauss after turning on the power.

Note

The DEGAUSS button is disabled when the screen menu is being displayed.

To manually degauss the CRT, exit the screen menu by pressing the MENU button.

On-screen menus

You can set color temperature, CHROMA set up, and other settings by using the on-screen menus.

EIA 19-inch rack mount bracket available

The monitor may be mounted on an EIA-standard 19-inch rack, using an optional mounting bracket MB-521 or slide rail SLR-104 (for PVM-D14L5A and PVM-D20L5A).

For details on mounting the monitor on the rack, refer to the Operating Instructions of the mounting bracket or slide rail.

Connections

How to Connect the AC Power Cord

Connect the AC power cord (supplied) to the AC IN socket on the rear panel and to a wall outlet.

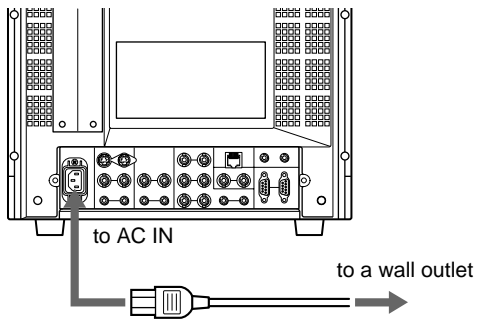

To connect an AC power cord securely with AC plug holder

- 1 Plug the power cord into the AC IN socket. Then, attach the AC plug holder (supplied) on top of the AC power cord.

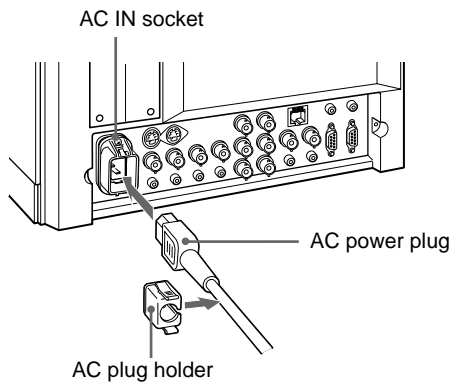

- 2 Slide the AC plug holder over the cord until it locks.

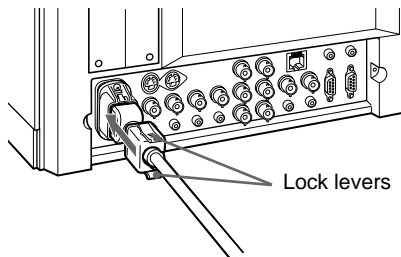

To remove the AC power cord

Pull out the AC plug holder while pressing the lock levers.

How to Connect a Cable to a BNC Connector

Connect a coaxial cable with the BNC plugs to the BNC connectors on the rear panel as illustrated below.

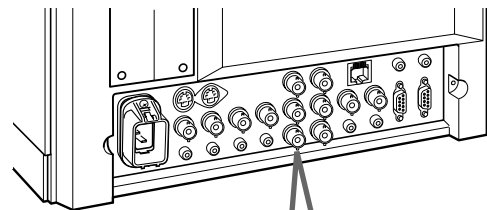

Insert the BNC plug into the connector on the rear panel, matching the slit and pin, and turn the BNC plug clockwise to secure the connection.

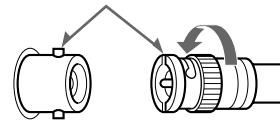

Location and Function of Parts and Controls

Control Panels

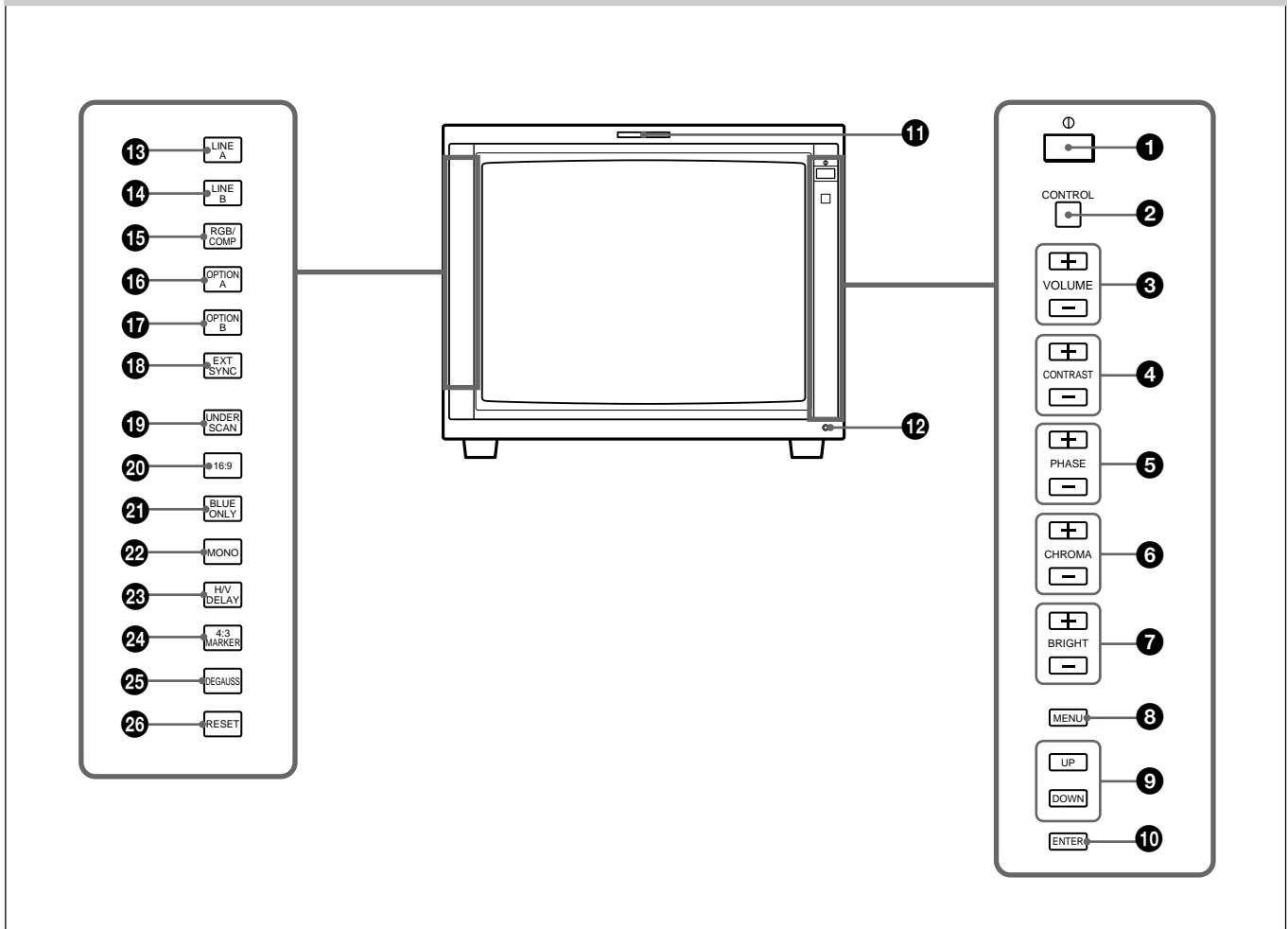

❶ POWER switch (⏻)

Press the switch to turn on the power. The operation buttons on both sides of the unit turn on. Press the switch again to turn off the power.

❷ CONTROL button

Press this button to turn on and enables the operation button. Press this button again to turn off and disables the operation buttons.

You can adjust the brightness of the operation buttons by using the UP or DOWN buttons.

❸ VOLUME control button

Press the + button to increase the volume or – button to decrease the volume.

❹ CONTRAST control button

Press the + button to make the contrast higher or the – button to make it lower.

❺ PHASE control button

Press the + button to make the complexion greenish or the – button to make it purplish.

❻ CHROMA control button

Press the + button to increase the color intensity or the – button to decrease it.

❼ BRIGHT (brightness) control button

Press the + button to increase the brightness or the – button to decrease it.

Notes

- The PHASE (❺) and CHROMA (❻) control buttons have no effect on the pictures of RGB signals.
- The PHASE (❺) control button has no effect on the PAL signals and pictures of component signals.

❽ MENU button

Press this button to display or exit the main menu.

9 UP button

Down button

Use these buttons to select an item from a menu or adjust the values. If the menu is not displayed, you can use these buttons to adjust the brightness for the control panels. You can adjust the brightness at 5 levels.

10 ENTER button

Press the button to confirm a selected item on the menu.

11 Tally lamp

Lights up when the video camera connected to this monitor is selected, indicating that the picture is being recorded.

For details on how to light the tally lamp, see page 25.

12 POWER indicator

Press the POWER switch, the indicator will light green.

13 LINE A (INPUT A) select button

Press this button to monitor the signal through the LINE A connector.

14 LINE B (INPUT B) select button

Press this button to monitor the signal through the LINE B connector.

15 RGB/COMP select button

Press this button to monitor the signal through the RGB/COMPONENT connectors.

You can set the RGB/COMPONENT in the menu screen. For details, see page 19.

16 OPTION A button

This button is used if an option board has been installed in the option slot in the monitor's rear. Press this button to monitor the image/audio signals from the option board input 1.

17 OPTION B button

This button is used if an option board has been installed in the option slot in the monitor's rear. Press this button to monitor the image/audio signals from the option board input 2.

(This button is disabled if BKM-129X or BKM-155DV is used.)

18 EXT SYNC (external sync) button

Press this button to operate the monitor on an external sync signal through the EXT SYNC IN connector.

19 UNDER SCAN button

Press this button (light on) for underscanning.

The display size is reduced by approximately 5% so that four corners of the raster are visible.

20 16:9 button

Press this button to monitor the signals of 16:9 picture.

Note

The aspect ratio is fixed to 16:9 when the signal other than 4:3 signal format is input.

21 BLUE ONLY button

Press this button to eliminate the red and green signals. Only blue signal is displayed as an apparent monochrome picture on the screen. This facilitates "chroma" and "phase" adjustments and observation of VCR noise.

22 MONO button

Press this button to display a monochrome picture.

When the button is pressed again, the monitor switches automatically to color mode.

23 H/V DELAY button

Press this button to observe the horizontal and vertical sync signals at the same time.

The horizontal sync signal is displayed in the left quarter of the screen; the vertical sync signal is displayed near the center of the screen.

24 4:3 MARKER button

When this button is pressed, a 4:3 marker is displayed and it is possible to check the 4:3 aspect area.

Note

The 4:3 marker is not displayed when the signals of the 4:3 aspect ratio are monitored or the monitor is in H/V delay mode

25 DEGAUSS button

Press this button momentarily. The screen will be demagnetized. Wait for 10 minutes or more before using this button again.

26 RESET button

Pressing this button while changing the menu setting resets the menu to the previous setting. Pressing this button while changing VOLUME, PHASE, CHROMA or BRIGHT resets the respective setting to the default.

Location and Function of Parts and Controls

Rear Panel

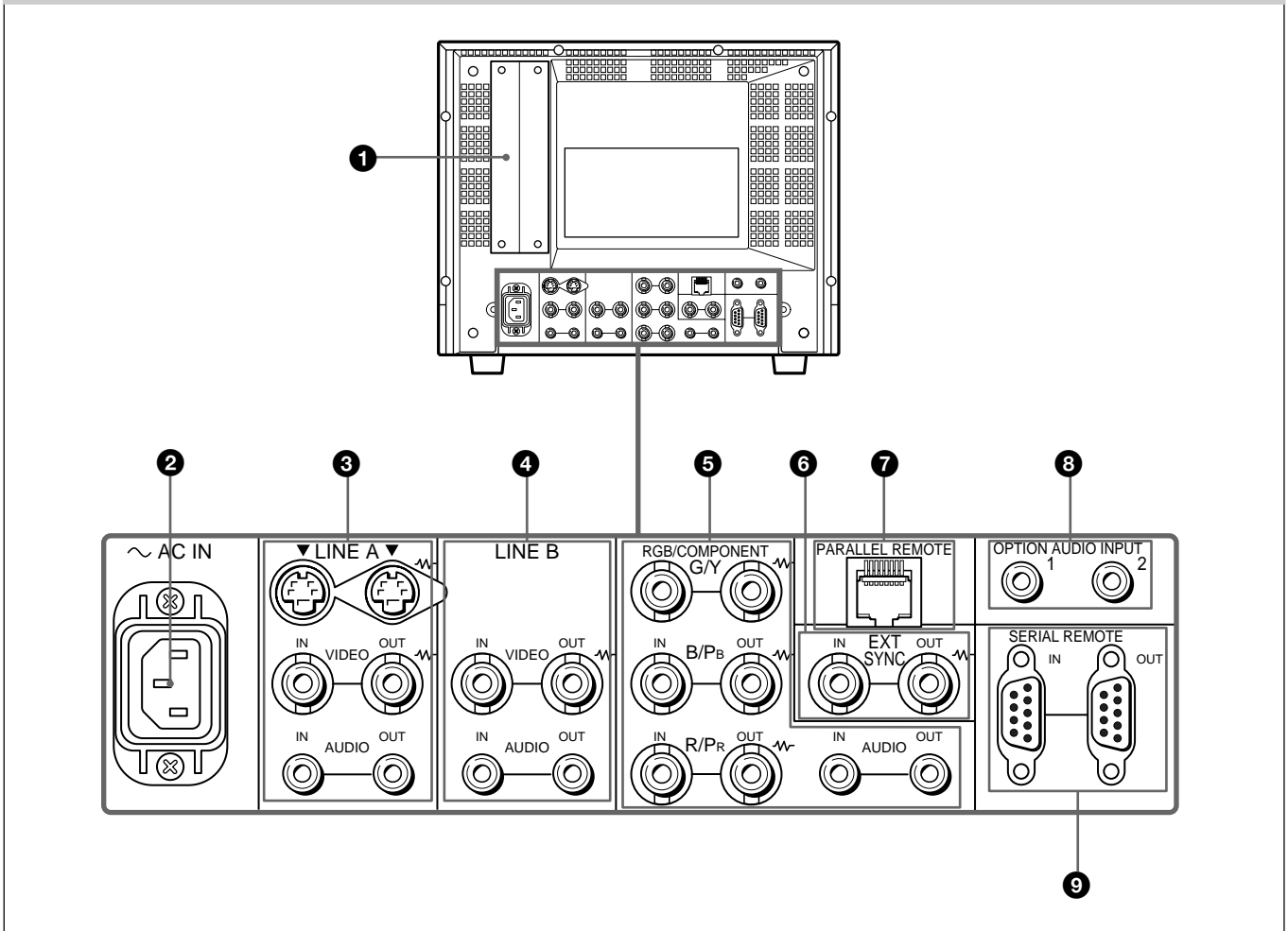

❶ Option slot

You can insert an option board into this option slot. To use this slot, remove the slot cover by removing the screws.

You can install only one option board. For details on how to install a board, refer to the Operating Instructions supplied with the option board.

❷ AC IN socket

Connect the supplied AC power cord to this socket and to a wall outlet.

❸ LINE A connectors

Line input connectors for the Y/C separate input/output of a VCR, composite video and audio signals and their loop-through output connectors.

To monitor the input signal through these connectors, press the LINE A select button on the front panel.

If you connect the Y/C input and video input simultaneously, the Y/C input is selected first.

Y/C IN (4-pin mini-DIN)

Connect to the Y/C separate output of a VCR, video camera or other video equipment.

Y/C OUT (4-pin mini-DIN)

Loop-through output of the Y/C IN connector. Connect to the Y/C separate input of a VCR or another monitor.

When the cable is connected to this connector, the 75-ohm termination of the input is automatically released, and the signal input to the Y/C IN connector is output from this connector.

VIDEO IN (BNC)

Connect to the video output of video equipment, such as a VCR or a color video camera.

For a loop-through connection, connect to the video output of another monitor.

VIDEO OUT (BNC)

Loop-through output of the VIDEO IN connector. Connect to the video input of a VCR or another monitor.

When the cable is connected to this connector, the 75-ohm termination of the input is automatically released, and the signal input to the VIDEO IN connector is output from this connector.

AUDIO IN (phono jack)

Connect to the audio output of a VCR or to a microphone via a suitable microphone amplifier. For a loop-through connection, connect to the audio output of another monitor.

AUDIO OUT (phono jack)

Loop-through output of the AUDIO IN connector. Connect to the audio input of a VCR or another monitor.

4 LINE B connectors

Line input connectors for the composite video and audio signals and their loop-through output connectors. To monitor the input signal through these connectors, press the LINE B select button on the front panel.

VIDEO IN (BNC)

Connect to the video output of video equipment, such as a VCR or a color video camera. For a loop-through connection, connect to the video output of another monitor.

VIDEO OUT (BNC)

Loop-through output of the VIDEO IN connector. Connect to the video input of a VCR or another monitor.

When the cable is connected to this connector, the 75-ohm termination of the input is automatically released, and the signal input to the VIDEO IN connector is output from this connector.

AUDIO IN (phono jack)

Connect to the audio output of a VCR or to a microphone via a suitable microphone amplifier. For a loop-through connection, connect to the audio output of another monitor.

AUDIO OUT (phono jack)

Loop-through output of the AUDIO IN connector. Connect to the audio input of a VCR or another monitor.

5 RGB/COMPONENT connectors

RGB signal or component (G/Y, B/P_B, R/P_R) signal input/output connectors and their loop-through output connectors.

To monitor the input signal through these connectors, press the RGB/COMP select button on the front panel.

G/Y, B/P_B, R/P_R IN (BNC)

When the EXT SYNC button on the front panel is not pressed (the indicator lights in green), the monitor operates on the sync signal from the G/Y signal.

To monitor the RGB signal

Connect to the analog RGB signal outputs of a video camera, etc.

To monitor the component signal

Connect to the component signal outputs of a Sony Betacam video camera, etc.

G/Y, B/P_B, R/P_R OUT (BNC)

Loop-through outputs of the G/Y, B/P_B, R/P_R IN connectors.

When the cables are connected to these connectors, the 75-ohm termination of the inputs is automatically released, and the signal inputs to G/Y, B/P_B, R/P_R IN connectors are output from these connectors.

To output the RGB signal

Connect to the analog RGB signal inputs of a video printer or another monitor.

To output the component signal

Connect to the component signal inputs of a Betacam video recorder, etc.

AUDIO IN (phono jack)

Connect to the audio output of video equipment when the analog RGB or component signal is input.

AUDIO OUT (phono jack)

Loop-through output of the AUDIO IN connector.

Location and Function of Parts and Controls

⑥ EXT SYNC (external sync) connectors

Press the EXT SYNC button on the front panel (the indicator lights in amber) to use the sync signal through this connector.

IN (BNC)

When this monitor operates on an external sync signal, connect the reference signal from a sync generator to this connector.

OUT (BNC)

Loop-through output of the IN connector. Connect to the external sync input of video equipment to be synchronized with this monitor.

When the cable is connected to this connector, the 75-ohm termination of the input is automatically released, and the signal input to the IN connector is output from this connector.

⑦ PARALLEL REMOTE terminal (modular connector)

Form a parallel switch and controls the monitor externally.

For details on the pin assignment and factory setting function assigned to each pin, see page 25.

⑧ OPTION AUDIO INPUT 1, 2 input connectors

If an option board has been installed in the option slot, input the audio into these connectors. Connect to the audio output of a VCR or to a microphone amplifier. You can connect up to 2 systems. To monitor the audio signals input from the OPTION AUDIO INPUT 1/2, press either the OPTION A or OPTION B buttons.

Note

If you use an optional board (e.g. BKM-150CP) with the audio capability, the audio input into this connector is ignored.

⑨ SERIAL REMOTE connector (D-sub 9 pins)

SERIAL REMOTE IN

Connect this connector to the Serial Remote Control connector on the BVM series unit.

You can control the functions except the menu in the control panel of the unit from the BVM.

SERIAL REMOTE OUT

Loop-through output of the SERIAL REMOTE IN connector.

Selecting the Menu Language

You can select one of six languages (English, German, French, Italian, Spanish, Japanese) for displaying the menu and other on-screen displays.

The factory setting is ENGLISH (English).

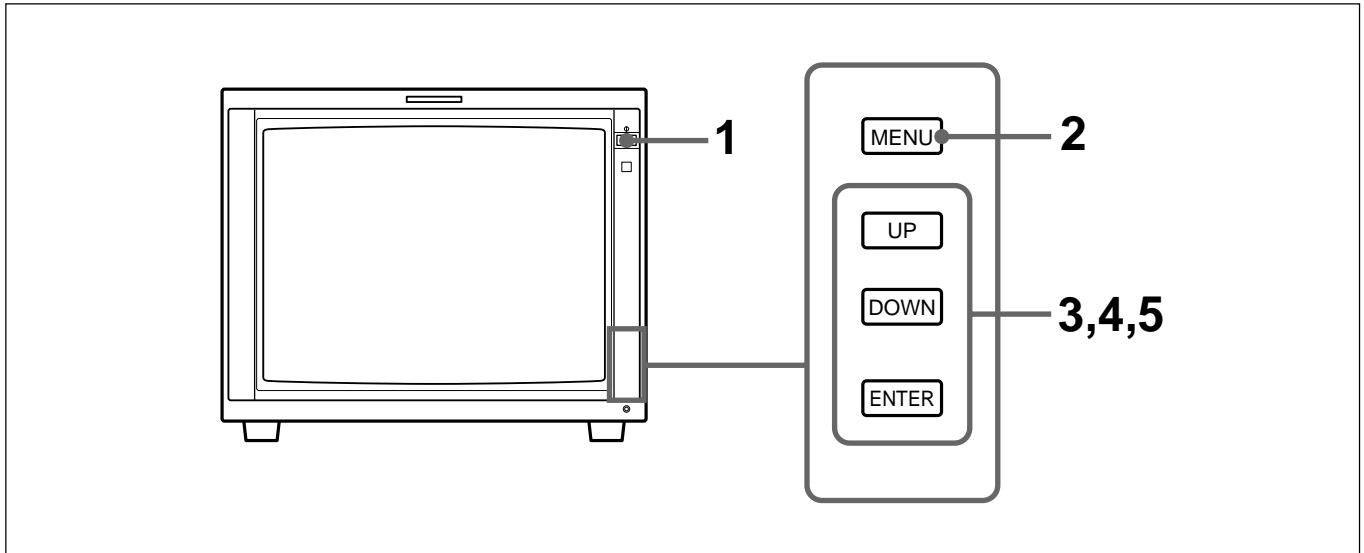

1 Press the POWER switch to turn on the monitor.

2 Press the MENU button.

The menu appears.

The menu presently selected is shown as a yellow button.

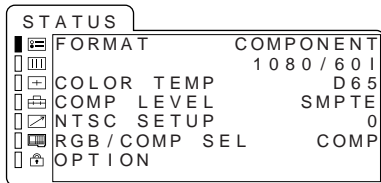

4 Press the UP or DOWN button to select “LANGUAGE,” then press the ENTER button. The selected item is displayed in yellow.

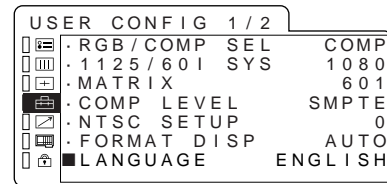

3 Press the UP or DOWN button to select the USER CONFIG 1/2 (User Configuration 1/2) menu, then press the ENTER button.

The setting items (icons) in the selected menu are displayed in yellow.

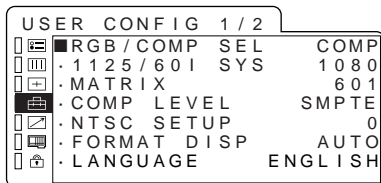

5 Press the UP or DOWN button to select a language, then press the ENTER button. The menu changes to the selected language.

To clear the menu

Press the MENU button.

The menu disappears automatically if a button is not pressed for one minute.

Using the Menu

The monitor is equipped with an on-screen menu for making various adjustments and settings such as picture control, input setting, set setting change, etc. You can also change the menu language displayed in the on-screen menu.

To change the menu language, see “Selecting the Menu Language” on page 13.

- 1 Press the MENU button.
The menu appears.
The menu presently selected is shown as a yellow button.

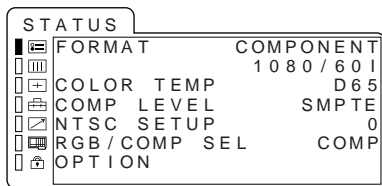

- 2 Use the UP or DOWN button to select a menu, then press the ENTER button.
The menu icon presently selected is shown in yellow and setting items are displayed.

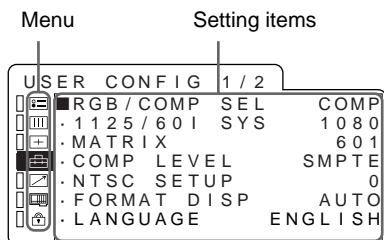

- 3 Select an item.
Use the UP or DOWN button to select the item, then press the ENTER button.
The item to be changed is displayed in yellow.

Note

If the menu consists of multiple pages, press UP/DOWN to go to the desired menu page.

- 4 Make the setting or adjustment on an item.

When changing the adjustment level:
To increase the number, press the UP button.
To decrease the number, press the DOWN button.
Press the ENTER button to confirm the number, then restore the original screen.

When changing the setting:

Press the UP or DOWN button to change the setting.

Press the ENTER button to confirm the setting.

Notes

- An item displayed in blue cannot be accessed. You can access the item if it is displayed in white.
- If the key protect has been turned on, all items are displayed in blue. To change any of the items, turn the key protect to OFF first.

For details on the key protect, see page 22.

To clear the menu

Press the MENU button.

The menu disappears automatically if a button is not pressed for one minute.

About the memory of the settings

The settings are automatically stored in the monitor memory.

To reset items that have been adjusted

Pressing the RESET button while you are adjusting the VOLUME, CONTRAST, PHASE, CHROMA or BRIGHT buttons on the control panels resets the level to the standard. Pressing the RESET button while you are adjusting any of the menu items resets the menu item to the previous setting.

Display List

STATUS menu

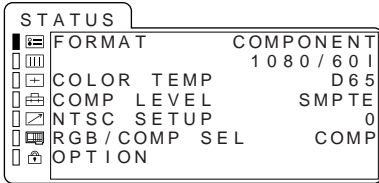

COLOR TEMP/BAL menu

When D65 or D93 is selected. (In the illustration, D65 is selected.)

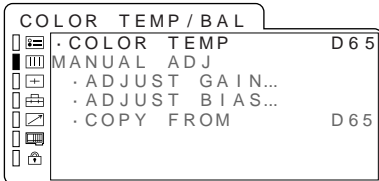

When USER is selected.

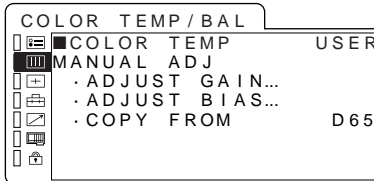

USER CONTROL 1/2, 2/2 menu

(NTSC)

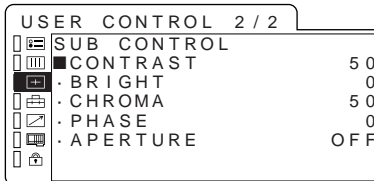
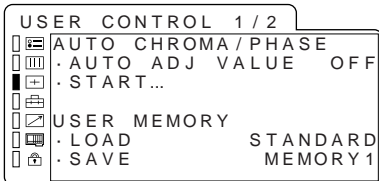

Display List

USER CONFIG 1/2, 2/2 menu

(USER CONFIG 1/2 menu)

USER CONFIG 1 / 2		
	.RGB/COMP SEL	COMP
	.1125/601 SYS	1080
	.MATRIX	601
	.COMP LEVEL	SMPTE
	.NTSC SETUP	0
	.FORMAT DISP	AUTO
	.LANGUAGE	ENGLISH

(USER CONFIG 2/2 menu)

USER CONFIG 2 / 2		
	■CAPTION	OFF
	.DEGAUSS DELAY	0
	.MARKER PHASE	0
	.MARKER WIDTH	0

REMOTE 1/2 PARALLEL menu, 2/2 SERIAL menu

(REMOTE 1/2 PARALLEL menu)

REMOTE 1 / 2 PARALLEL		
	.1PIN	LINE A
	.2PIN	LINE B
	.3PIN	TALLY R
	.4PIN	TALLY G
	.6PIN	EXT SYNC
	.7PIN	UNDERSCAN
	.8PIN	16:9

(REMOTE 2/2 SERIAL menu)

REMOTE 2 / 2 SERIAL		
	■SINGLE ADDRESS	0
	.GROUP ADDRESS	0
	.CH(1-4) CONFIG	CH1
	.INPUT	LINE A
	.ASPECT	4:3
	.SCAN SIZE	NORMAL

OPTION CONFIG menu

For details on the OPTION CONFIG menu screens, see page 21.

KEY PROTECT menu

KEY PROTECT		
	.KEY PROTECT	OFF

STATUS Menu

The STATUS menu is used to display the current status of the monitor. The following items are displayed:

- Signal format
- Color temperature
- Component level
- NTSC setup
- RGB/COMP select
- Option

COLOR TEMP/BAL Menu

The COLOR TEMP/BAL menu is used for adjusting the picture white balance.

You need to use the measurement instrument to adjust the white balance.

COLOR TEMP

Select the color temperature from among D65, D93 and USER setting.

MANUAL ADJ

If you set the [COLOR TEMP] to USER setting, the item displayed is changed from blue to white, which means you can adjust the color temperature.

ADJUST GAIN...

Adjust the color balance (GAIN).
Select [ADJUST GAIN...]. The [ADJUST GAIN...] screen appears. Adjust the gain by pressing the UP or DOWN button.

ADJUST BIAS...

Adjust the color balance (BIAS).
Select [ADJUST BIAS...]. The [ADJUST BIAS...] screen appears. Adjust the bias by pressing the UP or DOWN button.

COPY FROM

If you select D65 or D93 with the UP or DOWN button, the white balance data for the selected color temperature will be copied in the user setting.

USER CONTROL 1/2, 2/2 Menu

The USER CONTROL 1/2, 2/2 menu is used for adjusting the picture.

Items that cannot be adjusted depending on the input signal are displayed in blue.

AUTO CHROMA/PHASE

Adjusts color intensity (CHROMA) and tones (PHASE).

AUTO ADJ VALUE

Selects ON or OFF of the Auto adjustment. When set to OFF, this parameter is reset to the factory setting. When set to ON the automatically adjusted value is enabled.

START...

Display the color bar signals (Full/SMPTE/EIA/HD) on the screen and press ENTER. The AUTO ADJUSTMENT screen starts. Exit from the AUTO ADJUSTMENT screen using the MENU button after finishing adjustment. When the adjustment is done correctly, the AUTO ADJ VALUE is automatically enabled.

Note

If you have selected the full color bars, enter eight color bars.

USER MEMORY

SAVE

Saves the current VOLUME, CONTRAST, PHASE, CHROMA or BRIGHT settings on the control panels. You can select MEMORY1 or MEMORY2 area to save the data.

LOAD

Loads the VOLUME, CONTRAST, PHASE, CHROMA or BRIGHT setting of the control panels from the setting saved in a memory described above. If you select Standard, the settings are reset to the standards.

SUB CONTROL

You can finely adjust the adjustment range of buttons on the right-side of the front panel; CONTRAST, PHASE, CHROMA and BRIGHT buttons.

CONTRAST

Adjusts the picture contrast. You can adjust the contrast from 0 to 100.

BRIGHT

Adjusts the picture brightness. You can adjust the brightness from -50 to +50.

CHROMA

Adjusts color intensity. The higher the setting, the greater the intensity. The lower the setting, the lower the intensity. You can adjust the color intensity from 0 to 100.

PHASE

Adjusts color tones. The higher the setting, the complexion becomes greenish. The lower the setting, the picture becomes purplish. You can adjust the color tones from -50 to +50.

APERTURE

Adjusts the picture sharpness. The higher the setting, the sharper the picture. You can adjust the color sharpness from OFF to 100.

USER CONFIG 1/2, 2/2 Menu

You can select a language, RGB and component.
The settings in parentheses [] are factory settings.

RGB/COMP SEL

To monitor the signal fed through the RGB/
COMPONENT connectors, set the RGB or COMP
(component) signal in this menu. Press the UP or
DOWN button to select the RGB or COMP signal.
[COMP]

1125/60I SYS

Select the effective scanning lines for the 1125/60I
signal input. Select 1080 or 1035 of the scanning lines.
If the HD SDI is input, the system automatically
selects the scanning line type.
[1080]

MATRIX

Applied to normal image signal, 15K or 31K
component signals.
Press the UP or DOWN button to select 709 or 601.
[601]

COMP LEVEL

Select the component level from among three modes.
N10/SMPTE for 100/0/100/0 signal
BETA 7.5 for 100/7.5/75/7.5 signal
BETA 0 for 100/0/75/0 signal
[SMPTE]

NTSC SETUP

Select the NTSC setup level from two modes.
The 7.5 setup level is mainly used in North America.
The 0 setup level is mainly used in Japan.
[0]

FORMAT DISP

Select the display mode of the signal format from
among ON, OFF and AUTO.
[AUTO]

LANGUAGE

You can select the menu or message language from
among six languages (Japanese, English, German,
French, Italian, Spanish).
Select a language by pressing the UP or DOWN
button, then press the ENTER button. The selected
language is displayed.
[ENGLISH]

CAPTION

Select the caption display mode from among the
followings:
OFF, CAPTION 1, CAPTION 2, TEXT 1 and TEXT 2.
[OFF]

DEGAUSS DELAY

Set the delay time of auto degaussing to start working
after the power is turned on. The delay time can be set
within 0 to 99 seconds.
[0]

LANDING

This menu is provided only for PVM-D20L5A.
If the color is not uniform even after you press the
DEGAUSS button, you can adjust the landing so as to
obtain color uniformity on this screen. [50]
The following two methods are available to adjust the
landing.

When the signals of the horizontal lines are input and displayed:

Press the UP or DOWN button until the lines are
displayed on the screen as horizontally as possible.
The horizontal lines can be adjusted within 0 to 100.

When the signals of the white color are input and displayed:

Press the UP or DOWN button until the white color on
the screen become as uniform as possible. The level of
the white color signals can be adjusted within 0 to 100.

MARKER PHASE

You can adjust the 4:3 marker position within -10 to
+10.
[0]

MARKER WIDTH

You can adjust the 4:3 marker width within -10 to
+10.
[0]

REMOTE 1/2 PARALLEL Menu

Select the PARALLEL REMOTE connector pins for which you want to change the function.

You can assign various functions to 1 to 4 pins and 6 to 8 pins. The following lists the functions you can assign to the pins.

- -- (“--”: No function is assigned.)
- LINE A
- LINE B
- RGB/COMP
- OPTION A
- OPTION B
- TALLY RED
- TALLY GREEN
- UNDERSCAN
- 16:9
- EXT SYNC
- H/V DELAY
- BLUE ONLY
- MONO
- 4:3 MARKER
- DEGAUSS

Note

If you use the PARALLEL REMOTE function, you need to connect cables. For more details, see page 25.

REMOTE 2/2 SERIAL Menu

When you control this unit by using the serial remote mode from the BVM series unit, set the monitor single address and group address, or the channel number you want to assign in this menu.

SINGLE ADDRESS

The following lists the functions that can be performed by a serial remote command from a BVM series unit:

- CONTRAST adjustment
- BRIGHT adjustment
- CHROMA adjustment
- PHASE adjustment
- Numeric keypad 1 button
- Numeric keypad 2 button
- Numeric keypad 3 button
- Numeric keypad 4 button
- Underscan button
- Horizontal delay button*
- Vertical delay button*
- Monochrome button
- Aperture button
- 16:9 button
- SYNC button
- Blue only button
- Safe area button
- Degauss button
- * The system of this unit functions in the H/V DELAY mode.

GROUP ADDRESS

Set the monitor group address number. You can set within 0 to 99.

CH (1-4) CONFIG

Set the channel numbers (1 to 4) that have been assigned to the direct keys in the BVM series unit. Select from among CH1, CH2, CH3 and CH4. You can set the channel for INPUT, ASPECT and SCAN SIZE.

INPUT

Sets the input system to the selected channels. Select from among LINE A, LINE B, RGB/COMP, OPTION A and OPTION B.

ASPECT

Sets the aspect ratio of the picture. Select 16:9 or 4:3.

SCAN SIZE

Sets the size of a picture which is displayed by scanning the input signal. Select UNDER or NORMAL.

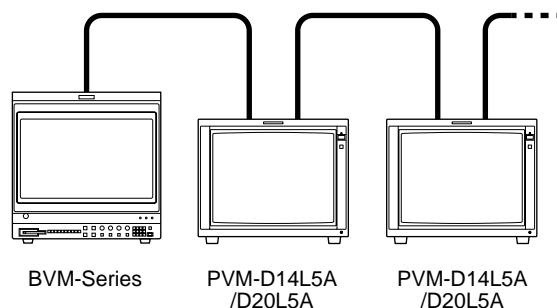

Serial Remote Control Configuration Example

Note

If you perform a single control multiple times continuously in the serial mode, the remote state may be disabled. In this case, execute the same control command several times until the remote state is recovered.

OPTION CONFIG Menu

Sets the option boards installed in the rear. Depending on the installed board, the displayed screen may differ. If no board is installed, the item settings are not displayed. After assigning the input signal, adjust the monitor's AUTO CHROMA/PHASE.

When installing the optional board BKM-150CP:

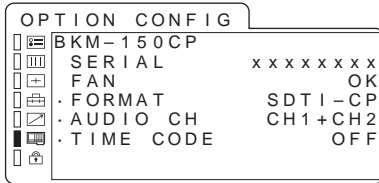

FORMAT

Sets the signal type.
Select SDTI-CP or SDI.

AUDIO

Selects an audio channel.

D1-SDI:

Select from among CH1+CH2 through CH15+CH16, or CH1 through CH16.

SDTI-CP:

Select from among CH1+CH2 through CH7+CH8, or CH1 through CH8.

The audio signal input to the OPTION AUDIO INPUT 1/2 jack is ignored.

TIME CODE

Selects the time code display.

D1-SDI:

Select VITC, RP188 or OFF.

SDTI-CP:

Select VITC, CP-TC1, CP-TC2, ES-TC1, ES-TC2 or OFF.

The following lists the abbreviations in the menu and their full names:

CP-TC1: SMPTE 331M System Item USER DATE/TIME STAMP

CP-TC2: SMPTE331M System Item CREATION DATE/TIME STAMP

ES-TC1: SMPTE 328M MPEG ES Editing Information TIME CODE1

ES-TC2: SMPTE 328M MPEG ES Editing Information TIME CODE2

PR188: SMPTE RP188 Time Code

VITC: SMPTE 12M VITC, SMPTE 266M D-VITC

When installing the optional board BKM-155DV:

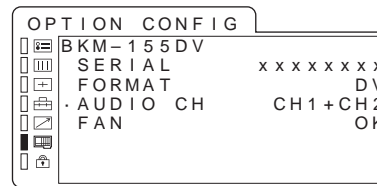

AUDIO

Selects an audio channel.

Select from among CH1+CH2, CH3+CH4, CH1/3, CH2/4, CH1/3+CH2/4, or CH1 through CH4.

The audio signal input to the OPTION AUDIO INPUT 1/2 jack is ignored.

When installing the optional board BKM-120D:

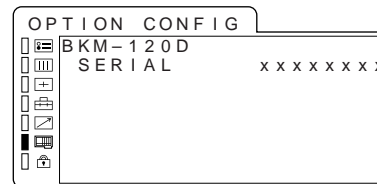

When installing the optional board BKM-142HD:

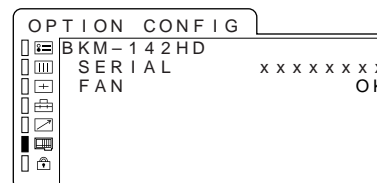

When installing the optional board BKM-129X:

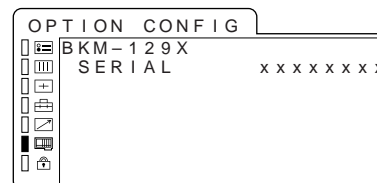

If the cooling fan in the BKM-142HD, BKM-150CP or BKM-155DV is stopped, the screen shows the following message in red "BKM-xxxxx FAN ERROR". In this case, you cannot select Option A or Option B.

KEY PROTECT Menu

You can lock the settings so that they cannot be changed by an unauthorized user.

Select OFF or ON.

If you set ON, all items are displayed in blue, indicating the items are locked.

Troubleshooting

This section may help you isolate the cause of a problem and as a result, eliminate the need to contact technical support.

- **The display is colored in green or purple.** → Select the correct input by pressing one of the buttons related to input.
- **The unit cannot be operated.** → The key protection function works. Set the KEY PROTECT setting to OFF in the KEY PROTECT menu.
- **The BKM-142HD, BKM-150CP, or BKM-155DV has been installed. The error message “BKM-xxxxx FAN ERROR” is displayed and you cannot select Option A or Option B.** → Repair the BKM-xxxxx.

Specifications

General

System

System	Total lines per frame	Active lines per frame	Frame rate (Hz)	Scanning format	Aspect ratio	Standard
575/50I (PAL)	625	575	25	2:1 Interlace	16:9/4:3	ITU 601
480/60I (NTSC)	525	483	30	2:1 Interlace	16:9/4:3	ITU 601
576/50P	625	576	50	Progressive	16:9/4:3	—
480/60P	525	483	60	Progressive	16:9/4:3	SMPTE 293M
1080/50I	1125	1080	25	2:1 Interlace	16:9	SMPTE 294M
1035/60I	1125	1035	30	2:1 Interlace	16:9	BTA S-001B
1080/60I	1125	1080	30	2:1 Interlace	16:9	SMPTE 274M/BTA S-001B
720/60P	750	720	60	Progressive	16:9	SMPTE 296M

PVM-D14L5A

CRT: HR Trinitron, EBU standard luminescent material

Power: AC 100 to 240 V, 50/60 Hz

Power consumption:
 Maximum 120 W, 1.2 to 0.6 A
 (when the optional BKM-150CP has been installed)
 Standard: 110 W, 1.1 to 0.5 A
 (Without optional board, 720/60P input)

Dimensions (max.):
 Approx. 346 × 280 × 424 mm
 (13 ⁵/₈ × 11 ¹/₈ × 16 ³/₄ inches)
 (w/h/d)

Mass: Approx. 17 kg (37 lb 8 oz)

PVM-D20L5A

CRT: HR Trinitron, EBU standard luminescent material

Power: AC 100 to 240 V, 50/60 Hz

Power consumption:
 Maximum 140 W, 1.4 to 0.7 A
 (when the optional BKM-150CP has been installed)
 Standard: 130 W, 1.3 to 0.6 A
 (Without optional board, 720/60P input)

Dimensions (max.):
 Approx. 452 × 414 × 500 mm
 (17 ⁷/₈ × 16 ³/₈ × 19 ³/₄ inches)
 (w/h/d)

Mass: Approx. 31 kg (68 lb 5 oz)

Input/output connectors

Input

LINE A input connector
 Y/C input 4-pin mini-DIN (1)
 See the pin assignment

VIDEO input
 BNC type (1) 1 V_{p-p} ± 6 dB
 negative synchronization

AUDIO input
 Pin jack (1) -5 dBu 47 kΩ or higher

LINE B input connector

VIDEO input
 BNC type (1) 1 V_{p-p} ± 6 dB
 negative synchronization

AUDIO input
 Pin jack (1) -5 dBu 47 kΩ or higher

RGB/Component input connector

BNC type (3)

RGB input 0.7 V_{p-p} ± 6 dB (Sync On Green, 0.3 V_{p-p} negative sync.)

Component input
 0.7 V_{p-p} ± 6 dB (75% chrominance standard color bar signal)

AUDIO input
 Pin jack (1) -5 dBu 47 kΩ or higher

Specifications

Externally synchronized input	BNC type (1) 0.3 to 8 V _{p-p} ± bipolarity ternary or negative polarity binary
Optional AUDIO input	Pin jack (2) –5 dBu 47 kΩ or higher
Remote input	Serial remote D-Sub 9-pin (1)
	Parallel remote Modular connector 8-pin (1)
Output	
LINE A output connector	
Y/C output	4-pin mini-DIN (1) Loop-through, with 75 Ω automatic terminal function
VIDEO output	BNC type (1) Loop-through, with 75 Ω automatic terminal function
AUDIO output	Pin jack (1) Loop-through
LINE B output connector	
VIDEO output	BNC type (1) Loop-through, with 75 Ω automatic terminal function
AUDIO output	Pin jack (1) Loop-through
RGB/Component output connector	
BNC type (3) RGB/Component output	Loop-through, with 75 Ω automatic terminal function
AUDIO output	Pin jack (1) Loop-through
Externally synchronized output	BNC type (1) Loop-through, with 75 Ω automatic terminal function
Remote output	Serial remote D-Sub 9-pin (1) Loop-through

Video signal

Frequency response	575/50I, 480/60I component inputs: 50 Hz to 10 MHz, (0 dB/–3 dB) RGB inputs: 48 Hz to 24 MHz, (0 dB/ –3 dB)
Aperture compensation ¹⁾	OFF: 0 dB ON: 2 dB to 6 dB 575/50I, 480/60I inputs: 5 MHz Input other than the above: 16 MHz

Picture performance

Normal scan	7% overscan of CRT effective screen area
Underscan	5% underscan of CRT effective screen area
Linearity	PVM-D14L5A H: 4% or less V: 4% or less PVM-D20L5A H: 5% or less V: 5% or less
Color temperature	D65, D93/USER (Adjustable color temperature: 5000K to 10000K)
Convergence error	PVM-D14L5A Center: 0.4 mm (¹ / ₃₂ inch) or less Peripheral: 0.5 mm (¹ / ₃₂ inch) or less PVM-D20L5A Center: 0.5 mm (¹ / ₃₂ inch) or less Peripheral: 0.7 mm (¹ / ₃₂ inch) or less
Raster size stability	H: 1.0% V: 1.0%
Resolution (at screen center)	600 TV lines (16:9) 800 TV lines (4:3)

1) The aperture cannot be compensated for RGB input signals.

Operating conditions

Temperature	0°C to 35°C (32°F to 95°F)
Humidity	30% to 85% (no condensation)
Pressure	700 hPa to 1060 hPa

Storage and transport conditions

Temperature	-10°C to 40°C (14°F to 104°F)
Humidity	0% to 90%
Pressure	700 hPa to 1060 hPa

Accessories supplied

- AC power cord (1)
- AC plug holder (1)
- Operating Instructions (1)

Design and specifications are subject to change without notice.

Pin assignment

Y/C IN connector (4-pin mini-DIN)

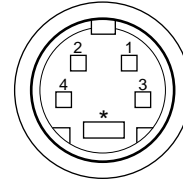

Pin No.	Signal	Description
1	Y-input	1 Vp-p, sync negative, 75 ohms
2	CHROMA-input Subcarrier-input	286 mVp-p (NTSC)/ 300 mVp-p (PAL) , burst Delay time between Y and C: within 0 ±100 nsec., 75 ohms
3	GND for Y-input	GND
4	GND for CHROMA-input	GND

PARALLEL REMOTE terminal

Modular connector
(8-pin)

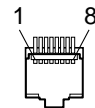

Pin number	Functions
1	Set input signal LINE A
2	Set input signal LINE B
3	Set red tally lamp on or off
4	Set green tally lamp on or off
5	GND
6	Select EXT sync
7	Select underscan
8	Select aspect ratio 16:9

You can allocate functions to 1 to 4 pins or 1 to 8 pins in the Remote menu.

Wiring required to use the Remote Control

Connect the function you want to use in remote to the Ground (Pin 5).

Specifications

Dimensions

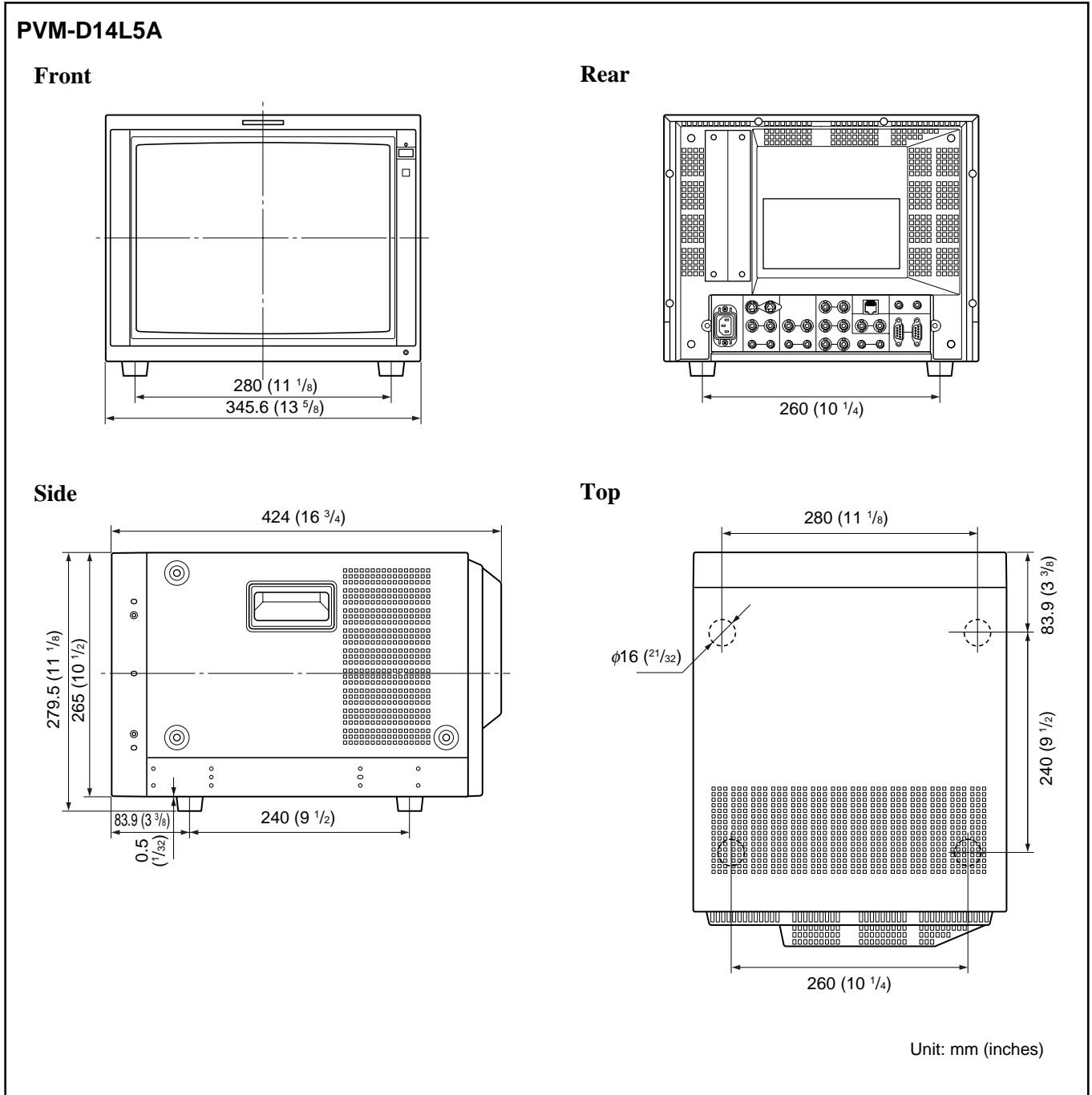

PVM-D20L5A

Front

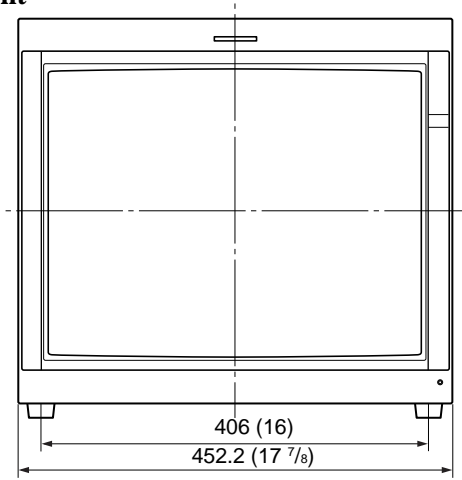

Rear

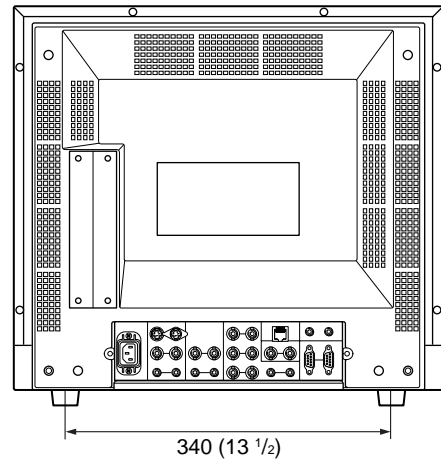

Side

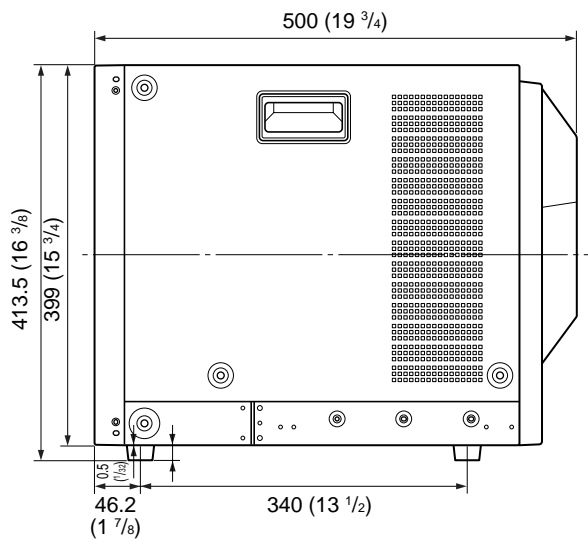

Top

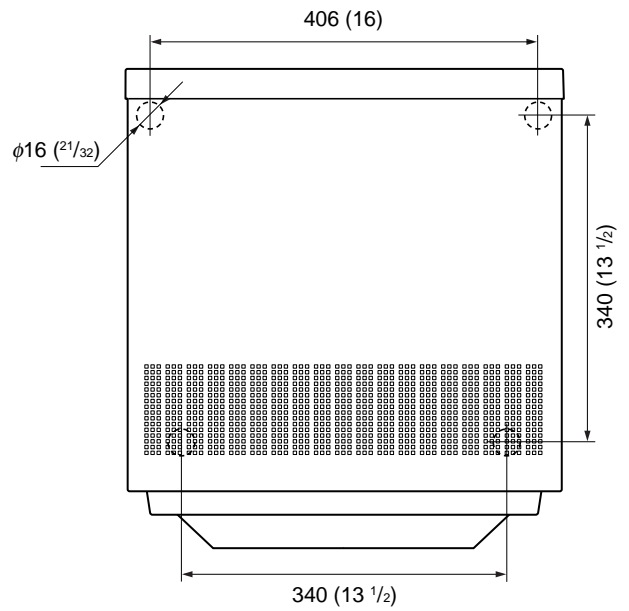

Unit: mm (inches)

<http://www.sony.net/>

Printed on recycled paper

Printed in Japan