

APPLICATION NOTE

ECO-Monitor

AN00057





Purchase of Philips I²C components conveys a license under the I²C patent to use the components in the I²C system, provided the system conforms to the I²C specifications defined by Philips.

© Philips Electronics N.V. 2000

All rights are reserved. Reproduction in whole or in part is prohibited without the prior written consent of the copyright owner.

The information presented in this document does not form part of any quotation or contract, is believed to be accurate and reliable and may be changed without notice. No liability will be accepted by the publisher for any consequence of its use. Publication thereof does not convey nor imply any license under patent- or other industrial or intellectual property rights.

APPLICATION NOTE

ECO-Monitor

AN00057

Author(s):

J. Moors, J. Schatorie
Philips Semiconductors Systems Laboratory Eindhoven,
The Netherlands

Keywords

Autosync monitor
17 " Monitor
I2C controlled
Electro Magnetic Compatibility
Eco/green design

Number of pages: 79

Date: 08-11-2000

Summary

This application note includes a functional description of the circuit of the ECO monitor featuring:

- Universal auto sync design capable of driving 17" picture tubes;
- Global mains supply 90 .. 264 V;
- Horizontal deflection 30 .. 70 kHz;
- Vertical deflection 50 ..150 Hz;
- 17" high resolution, high contrast picture tube with 0.27 mm dot pitch;
- Combined EHT and horizontal deflection;
- DDC controlled.

You will find in this document:

- Complete schematics;
- Board layout;
- Parts list;
- Alignment procedure;
- Debugging procedure;
- Oscillograms;
- Embedded software description.

Last minute changes are described in the 'Modifications' chapter.

In the chapter 'Windows I2C-control software for monitor IC's' you will find an introduction to the I2C (Inter IC Communication bus) PC software for monitors. **Be aware there is a special note in this chapter about controlling the ECO Monitor via PC I2C-software!**

CONTENTS

1. INTRODUCTION	8
1.1 Specification.....	8
1.2 Block diagram	10
2. FUNCTIONAL CIRCUIT DESCRIPTION	11
2.1 Switch mode power supply	11
2.2 Microcontroller	14
2.3 Deflection controller	15
2.4 Horizontal deflection.....	17
2.4.1 B+ circuit.....	17
2.4.2 Line driver and output stage.....	18
2.4.3 EW Modulator.....	19
2.4.4 EHT section.....	20
2.5 Vertical deflection output stage.....	21
2.6 Dynamic focus amplifier	22
2.7 Rotation.....	23
2.8 Video.....	23
2.8.1 Power	23
2.8.2 Processing	24
2.8.3 OSD.....	25
2.8.4 Output stage	26
2.8.5 CRT.....	26
3. SCHEMATICS	28
3.1 Switch Mode Power Supply	29
3.2 Micro controller	30
3.3 Deflection controller	31
3.4 Rotation circuit.....	32
3.5 Horizontal deflection circuit.....	33
3.6 Vertical deflection circuit.....	34
3.7 Video.....	35
4. BOARD COMPONENT PLACEMENT.....	36
4.1 Main board	36
4.2 Video board.....	37
5. PCB LAYOUT	38
5.1 Main board	38
5.2 Video board.....	39
6. BILL OF MATERIALS.....	40
6.1 Main board	40
6.2 Video board.....	47
7. MODIFICATIONS.....	50
8. ALIGNMENT	51
8.1 Used equipment.....	51
8.2 Jumper settings.....	51

8.3	First time adjustment.....	52
8.4	Geometrical adjustment.....	52
8.5	Colour adjustment.....	53
8.6	Focus adjustment.....	53
8.7	Adjusting other video modes.....	53
8.8	Programming serial number.....	54
9.	DEBUGGING.....	55
10.	OSCILLOGRAMS.....	57
10.1	Horizontal Deflection.....	57
10.2	Vertical deflection.....	59
10.3	Dynamic focus.....	60
11.	DESIGN & EMC CONSIDERATIONS.....	61
11.1	EMC.....	61
11.2	TCO'99.....	61
11.3	Lay-out hints.....	61
11.3.1	Ground track.....	61
11.3.2	Vertical deflection.....	62
11.3.3	Horizontal deflection output stage.....	62
11.3.4	Video.....	62
12.	EMBEDDED SOFTWARE.....	63
12.1	Video mode adaptation.....	63
12.2	OSD status messages.....	64
12.3	User interface and OSD menu control.....	64
12.3.1	OSD menu layout.....	65
	<i>OSD user menu.....</i>	<i>65</i>
	<i>OSD service menu.....</i>	<i>66</i>
12.3.2	Menu item descriptions.....	68
	<i>User store and exit.....</i>	<i>68</i>
	<i>User recall.....</i>	<i>68</i>
	<i>Factory recall.....</i>	<i>68</i>
	<i>Colour Temperature (CT) selection.....</i>	<i>68</i>
12.4	External interface control.....	68
12.4.1	DDC.....	68
12.5	List of supported VESA commands.....	69
12.6	DPMS control.....	71
12.7	Horizontal linearity capacitors.....	71
12.8	NVM related items.....	71
12.8.1	Factory pre-programmed video modes.....	71
12.8.2	NVM memory map layout.....	72
13.	WINDOWS I²C-CONTROL SOFTWARE FOR MONITOR IC'S.....	76
13.1	Hard- and Software Requirements.....	76
13.2	Monitor IC's that can be controlled.....	76
13.3	I2C control modes.....	77
14.	ACKNOWLEDGEMENTS & REFERENCES.....	78
14.1	Application notes.....	78
14.2	Datasheets.....	78

APPENDIX 1 TDA4856 horizontal frequency range..... 79

I. INTRODUCTION

This monitor is intended as an application proposal for 17" mid-end monitor designs and for the promotion of the following key components.

Key component	Description
BU4523AF	Silicon Diffused Power Transistor for horizontal deflection stage
BYM357X	Power combi diode, flyback diode plus EW modulator diode in one package
AT2097/32B	High voltage transformer
M41EHN323X160/G341BA	17" High resolution, high contrast colour monitor tube assembly
P87C380	Monitor micro controller
PHP18NQ20T	N-channel PowerMOS Transistor for linearity capacitor switching
TDA4856	I ² C-bus controlled auto sync deflection controller for PC Monitors
TDA4863J	Vertical deflection booster
TDA4887PS	160 MHz I ² C-bus controlled video preamplifier
TEA1507	Greenchip II, SMPS control IC
CU15/50	Base drive transformer
CU20d3	Mains filter choke
CU15	Dynamic focus transformer
AT4042_32A	Linearity balance corrector coil
CE423V	SMPS transformer
CU20	Bridge coil for EW modulator

Note: the TEA1507 is not in mass production yet, the P87C380 is a discontinued product.

1.1 Specification

General		
	Mains voltage	90 - 264Vac
	Mains frequency	50 - 60Hz
	Power consumption	typical <75W
	Standby power	< 1.5W
	Weight	20 kg
	Dimensions (W x H x D)	423 x 426 x 405 mm ³
Picture tube		
	Type	M41EHN323X160/G341BA
	Dot triplet pitch	0.27 mm
	Recommended active screen area	312 x 234 mm ²

	Anode voltage	26.0 kV
	Hor. deflection coil inductance	180 μ H
	Maximum advised frequency	66 kHz
	Vertical deflection coil inductance	6.3 mH
	Vertical deflection coil resistance	6.3 Ohm
Video		
	Maximum pixel rate	120 MHz
	Video input	VGA input connector
	Video input signal	700 mVp-p linear
	Video input impedance	75 Ohm
Sync signals		
	Level	TTL
	Polarity	Positive or negative
	Horizontal frequency	30 to 70 kHz
	Vertical frequency	50 to 150 Hz
	Sync Inputs	Separate horizontal and vertical inputs via VGA connector Composite sync on horizontal input via VGA connector
User interface		
	Keypad	Three button control
	On Screen Display menu	Graphical indication of monitor settings
Control		
	Keypad	In monitor cabinet
	DDC	Via VGA cable
	I2C bus control	External I2C cable connected with a PC with I2C menu software for demo purpose only

1.2 Block diagram

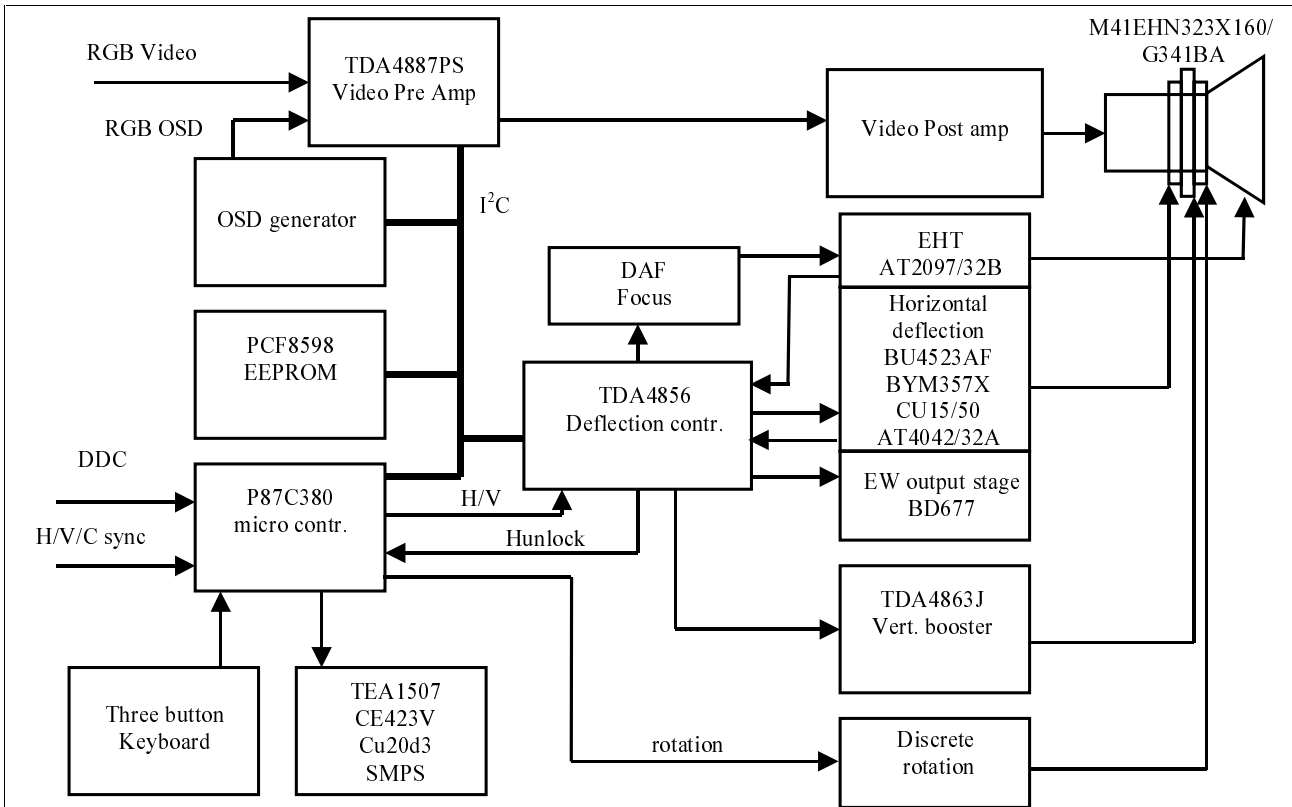

Figure 1-1 Block diagram

2. FUNCTIONAL CIRCUIT DESCRIPTION

2.1 Switch mode power supply

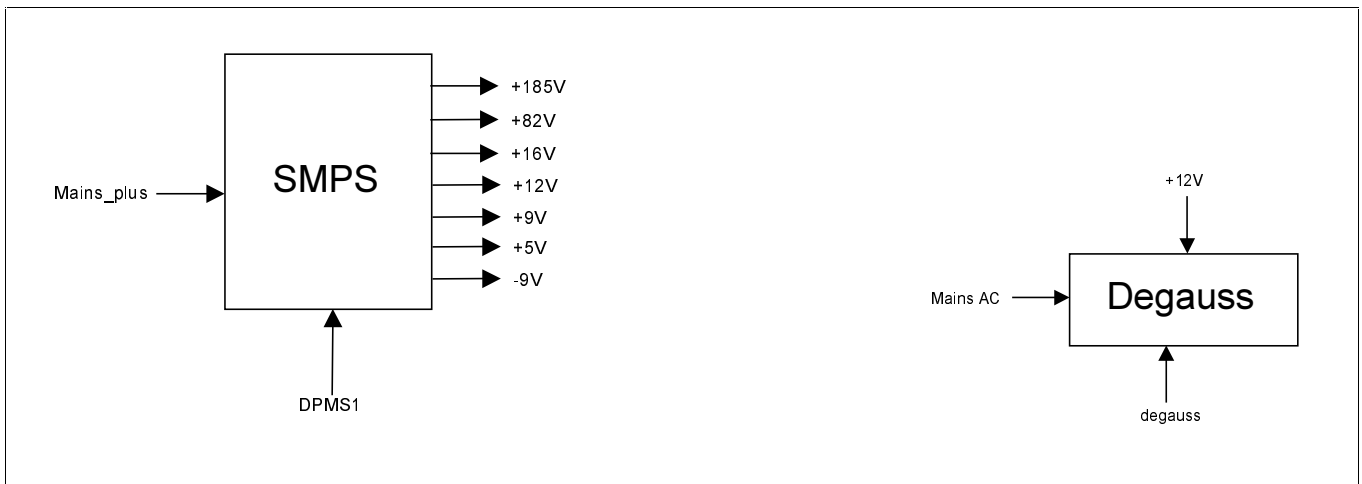

Figure 2-1 Mains SMPS block schematic

Signal name	Type	Connected with	Explanation
Mains_AC	Supply	Line voltage	Line voltage
Degauss	Input	μC	Degauss activated by μC
Mains_plus	Supply	Inrush current limiter	Rectified from mains_AC
DMPS1	Input	μC	Switch SMPS to burst-mode
+185V	Supply	Horizontal deflection DC restoration Dynamic focus amplifier	
+82V	Supply	Vertical deflection flyback Video booster	
+16V	Supply	Horizontal deflection driver B+ circuit	
+12V	Supply	Degauss, EW modulator Horizontal deflection output stage, Video board power Deflection controller Beam current measurement Grid1 protection circuit	Stabilised out of +16V with voltage regulator LM7812
+9V	Supply	Vertical deflection Rotation	
+5V	Supply	Micro controller EEPROM OSD generator	Stabilised out of +9V with voltage regulator LM7805
-9V	Supply	Vertical deflection	

		Rotation Heater current	
--	--	----------------------------	--

The GreenChip™ TEA1507 is a variable frequency SMPS controller designed for a Quasi-Resonant Flyback converter operating directly from the rectified universal mains (see Figure 2-2). The topology is particularly suitable for TV and monitor supplies. During nominal load it operates in a critical conduction mode including zero/low voltage switching (ZVS/LVS). The ZVS/LVS is achieved by the Quasi-Resonant behaviour of the voltage across the switch. This is also called the Quasi-Resonant mode. On account of the discontinuous character, the converter starts each period with zero inductor current.

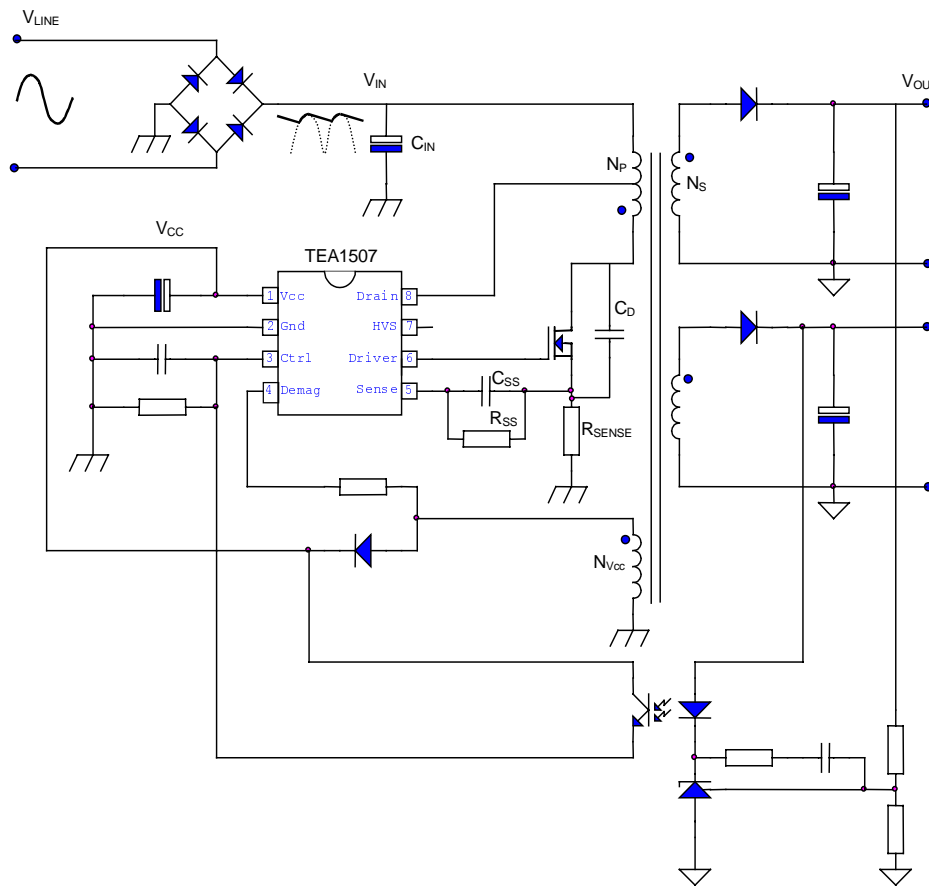

Figure 2-2 Basic application diagram

The control method applied in the TEA1507 is known by the name ‘Current-mode control’. Control takes place by varying the on-time of the switch. The frequency is determined by the actual magnetisation time of the transformer. The input voltage and/or the output load influence the frequency. Feedback is achieved by means of an opto-coupler, which makes it possible to detect the output voltage at secondary side, which means a good stabilisation and good ripple suppression can be obtained.

The controller provides two different types of stand-by possibilities. The first is Frequency Reduction to minimise the power losses at minimum output load. This feature enables stand-by power consumption down to 3W and needs no additional circuitry. Especially the Frequency Reduction Mode is a very important benefit of this controller. The second standby-mode for power dissipation down to 1W is called Burst Mode, which

requires some additional circuitry. This burst-mode is activated by setting the DPMS1 signal high, which is done by the micro-controller. In this monitor the Burst Mode is used.

The key features of the TEA1507 are:

Distinctive features

- Operates from universal mains input $85V_{AC} - 276V_{AC}$
- High level of integration leads to a very low external component count
- Leading Edge Blanking (LEB) for current sense noise immunity

Green features

- Valley (zero/low voltage) switching for minimal switching losses
- Efficient Quasi-Resonant mode at high power levels
- Frequency Reduction Mode at low power stand-by for improved system efficiency (power consumption down to 3W)
- On-chip start-up current source
- Burst Mode operation for very low stand-by levels (power consumption down to 1W)

Protection features

- Safe-Restart Mode
- Mains dependent operation enabling level (start-up level)
- Under Voltage Protection (UVLO) for fold-back during overload
- Continuous mode protection by means of demagnetisation detection
- Soft (re)Start (adjustable)
- Accurate Over Voltage Protection (OVP) over demag (adjustable to winding ratio)
- Cycle-by cycle Over Current Protection (OCP)
- Input voltage independent Over Power Protection (OPP)
- Short Winding Protection (SWP)
- Ton max Protection
- Over Temperature Protection (OTP)

These features enable an engineer to design a reliable supply with a reduced number of external components. They also give the possibility to deal with requirements on minimum power consumption during stand-by or other system idle modes.

See also application note **AN00047** *75W SMPS with TEA1507*.

2.2 Microcontroller

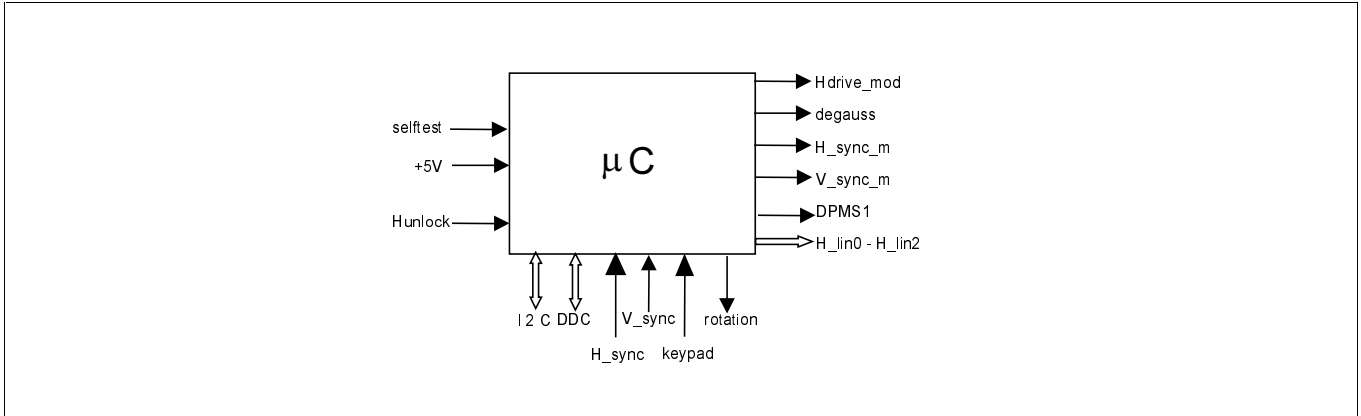

Figure 2-3 Microcontroller block schematic

Signal name	Type	Connected with	Explanation
+5V	Supply	SMPS EEPROM OSD generator	
I2C	I/O	Deflection controller EEPROM Video processor OSD generator	Inter IC communication bus μC is always master, all other IC's are slaves
Selftest	Input	VGA connector	Check if VGA cable and PC are connected or not (0V=conn. 5V=not conn.)
DDC	I/O	VGA connector	DDC communication with PC
H_sync	Input	VGA connector	TTL level horizontal sync signal + composite sync signal
V_sync	Input	VGA connector	TTL level vertical sync signal
Keypad	Input	3 button keypad	ADC input that determines which button is pressed
Rotation	Output	Rotation circuit	DAC output 0 to 5 Volt
Degauss	Output	Degauss circuit	Activates degaussing Off = 0 Volts On = 5.0 Volts
H_sync_m	Output	Deflection controller	Horizontal sync signal processed by μC
V_sync_m	Output	Deflection controller OSD generator	Vertical sync signal processed by μC
DPMS1	Output	SMPS	Switch SMPS to burst-mode; active high
H_unlock	Input	Deflection controller Grid1 protection circuit	High if deflection controller is out of lock
Hdrive_mod	Output	Horizontal deflection driver	DAC output depending on horizontal size setting from 0 to 5 Volt

H_lin0-H_lin2	Output	Linearity capacitor switches	Switch linearity capacitors on/off; safe setting = low
---------------	--------	------------------------------	--

The micro controller takes care of the monitor control functions. These include hardware-mode detection, linearity (=S) capacitor switching, DPMS mode, degaussing, I2C commands and some DAC controls.

Jumper settings (see also the alignment chapter):	Jumper #	Explanation
Service_mode_not (pin19 of IC240) to ground	J240	Service mode (extended control menus)

2.3 Deflection controller

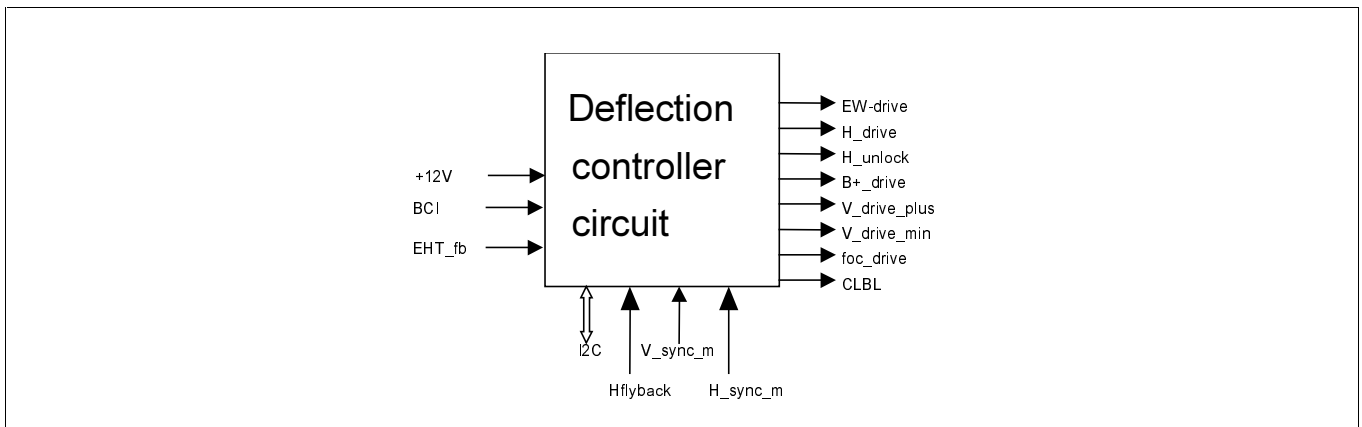

Figure 2-4 Deflection controller block schematic

Signal name	Type	Connected with	Explanation
+12V	Supply	Degauss Horizontal deflection output stage, EW modulator Video board power Beam current measurement Grid1 protection circuit SMPS	Stabilised 12V
I2C	Input	µC EEPROM Video processor OSD generator	Inter IC communication
Hflyback	Input	Horizontal deflection output stage, Video processor, OSD generator	Flyback Pulse High = 30V Low = 0V
V_sync_m	Input	µC	Vertical sync signal processed by µC

		OSD generator	
H_sync_m	Input	μC	Horizontal sync signal processed by μC
H_drive	Output	Horizontal deflection driver	Line drive pulses (open collector output)
H_unlock	Output	μC, Grid1 protection circuit	Out of lock indication and fast blanking signal
B+_drive	Output	B+ circuit	B+ drive pulses (open collector output)
V_drive_plus, V_drive_min	Output	Vertical deflection	Differential sawtooth current output for vertical deflection
Foc_drive	Output	Dynamic focus amplifier	Vertical dynamic focus signal
EW_drive	Output	EW modulator	EW-modulation output to EW-amplifier
BCI	Input	Line output transformer	Beam current information
EHT_fb	Input	Line output transformer	EHT information
CLBL	Output	Video processor	Two-level sandcastle pulse. Upper level is video clamping. Lower level is vertical blanking pulse.

The TDA4856 is a high performance and efficient solution for auto-sync monitors. All functions are controllable by I²C-bus. The TDA4856 provides synchronisation processing, horizontal and vertical synchronisation with full auto-sync capability and very short settling times after mode changes. External power components are given a great deal of protection. The IC generates the drive waveforms for DC-coupled vertical boosters such as TDA486x and TDA835x.

The TDA4856 provides extended functions e.g. as a flexible B+ control, and extensive set of geometry control facilities, and a combined output for horizontal and vertical focus signals.

See also application note **AN97072** *Bus_C Controlled Autosync Deflection Controller TDA4853/54*.

Horizontal frequency range calculation:

The horizontal oscillator is synchronised in the frequency range from 30 to 70 kHz (determined by resistors R295 and R296 and capacitor C288). The value of R295 and R296 are calculated in the formulas mentioned in APPENDIX 1 TDA4856 horizontal frequency range. It is best to use components with 2% tolerance for R295, R296 and C288. Capacitor C288 should not be changed (optimal for low jitter).

Configuration of the B+ part of the deflection controller:

The B+ section of the deflection controller is applied in feedback configuration. The divided EHT voltage is fed back to the deflection controller, which adjusts the B+_drive pulse according to the EHT voltage. Without this feedback loop the EHT and as a result Vg2 (grid 2 voltage) vary too much, resulting in a background colour variation on the screen. The bandwidth of the loop is made that slow that the EHT is varied in one frame; the time constant is a couple of frames. This means that vertical size is not affected in the steady state when going from black screen to white screen. So only horizontal size has to be adjusted because of the compensation of the EHT breathing. This adjustment of the horizontal size is done by applying beam current information to HSMOD, which modulates the size via the EW Modulator.

ASCOR is internally connected to PLL2 (control bit ACD=1).

B+ section design hints:

The current source needed for the sawtooth generator at pin 5 (Bsense) must be active until the deflection controller is switched off. See AN00042 *Failure Mechanisms of the Line Output Transistor* for more information.

Csense of B+ section (=C287) must have a low temperature coefficient for a stable horizontal size.

Cbop (=C285) must be positioned close to pin 3 and pin 7 of deflection controller. This capacitor is necessary for stability of the internal OTA (opamp with current output).

2.4 Horizontal deflection

2.4.1 B+ circuit

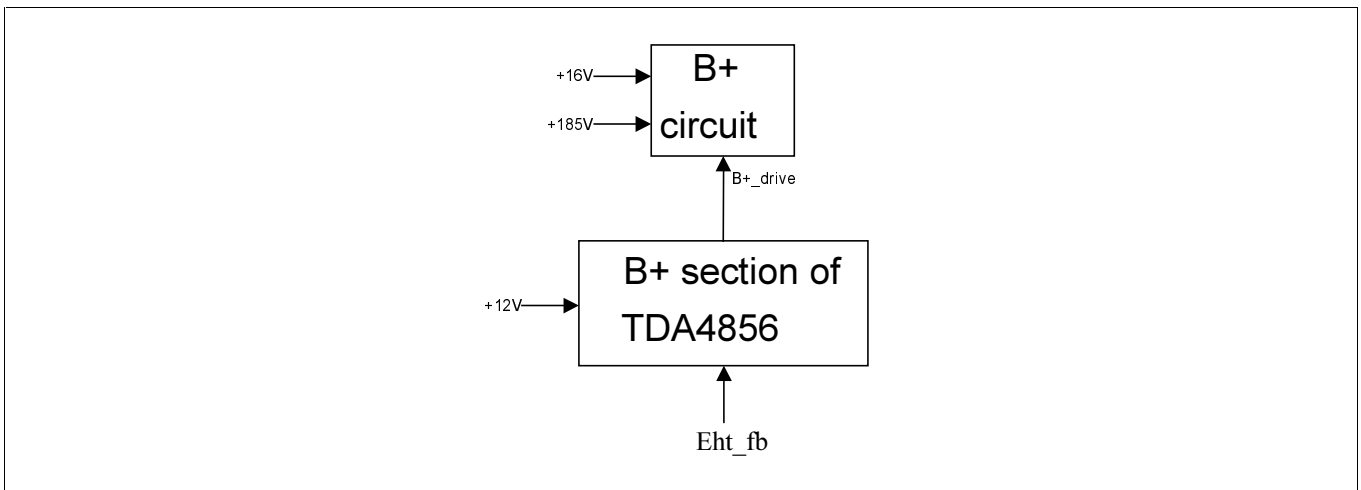

Figure 2-5 B+ section block diagram

Signal name	Type	Connected with	Explanation
+12V	Supply	SMPS, Degauss Video board power Horizontal deflection output stage, EW modulator Beam current measurement Grid1 protection circuit	Stabilised 12V
+16V	Supply	SMPS Horizontal deflection driver	
+185V	Supply	SMPS Dynamic focus amplifier DC restoration circuit	
Eht_fb	Input	Line output transformer	EHT information
B+_drive		B+ section	B+ drive pulses

- The B+ circuit is a Buck converter (=step-down converter) in feedback mode. The EHT voltage is divided and fed back to pin 5 of the deflection controller.
- The B+ drive signal is buffered with TR343 and TR344;
- D341 and R343 are added for protection;
- An extra series resistor must be placed close to the deflection controller at every pin connected to a long track. For information about design considerations and solutions regarding improvement of the reliability of the horizontal deflection output stage see AN00042 *Failure Mechanisms of the Line Output Transistor*.

2.4.2 Line driver and output stage

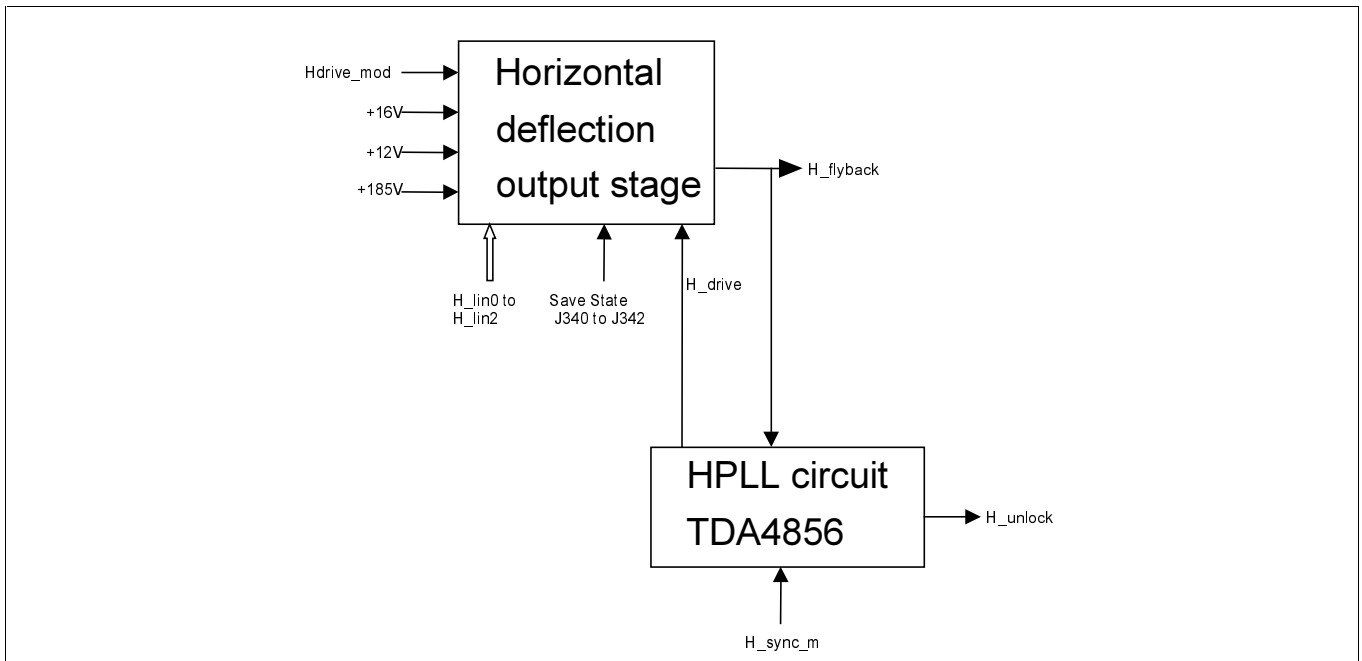

Figure 2-6 Line driver and output stage block diagram

Signal name	Type	Connected with	Explanation
Hdrive_mod	Input	μC	Horizontal drive modulation
+16V	Supply	SMPS B+ circuit	
+185V	Supply	SMPS, DC restore circuit, Dynamic focus amplifier	
+12V	Supply	SMPS Degauss Video board power B+ circuit, EW modulator Beam current measurement Grid1 protection circuit	
H_lin0 to H_lin2	Input	μC	Linearity capacitor switches control
Safe State J340 to J342	Input	Shortcut/grounded or open	Shortcut/grounded: all linearity capacitor switches are in safe state

			Open: linearity capacitor switches controlled by μC
H_drive	Input	Deflection controller	Line drive pulses
H_sync_m	Input	μC	Horizontal sync processed by μC
H_flyback	Output	Deflection processor, OSD generator, Video processor	Line flyback pulse
H_unlock	Output	Grid1 protection circuit μC	Out of lock indication and fast blanking signal

Driver stage

The horizontal driver stage is built around transformer T342. The base drive current is varied depending on the horizontal frequency (by means of hardware) and on the horizontal size setting (by means of software via microprocessor, “Hdrive_mod”). The maximum frequency is limited to 70 kHz.

Output stage

The diode D343 ensures the high efficiency of the driver stage, also called ‘nice drive’. The specification for this diode is:

- I_F : must match the peak deflection current,
- V_F : should be below 1V at peak deflection current but preferably lower in order not to deteriorate linearity),
- V_{REV} : determined by the forward recovery voltage of flyback diode D347 plus present voltage on the collector of the horizontal output transistor BU4523AF.

Due to parasitic capacitance at the collector of TR349 a damper filter is used to prevent from oscillation. The damper filter consisting of R346, L341 and C343 is tuned to this specific deflection output stage.

Linearity and linearity balance control

The monitor has one linearity balance corrector coil L345. Horizontal linearity is controlled by switching the linearity (=S) capacitors on or off. This switching is done by the microprocessor.

2.4.3 EW Modulator

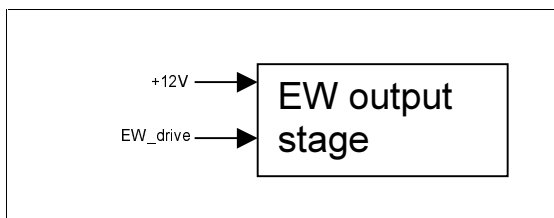

Signal name	Type	Connected with	Explanation
+12V	Supply	SMPS, Degauss Video board power Deflection controller, Horizontal deflection output stage	

		Beam current measurement Grid1 protection circuit	
EW_drive	Input	Deflection controller	East-West modulation voltage

The east-west amplifier amplifies the east-west output voltage from the deflection controller. This east-west output voltage contains also the horizontal size information. The east-west modulator diode is combined with the flyback diode in one package: D347.

2.4.4 EHT section

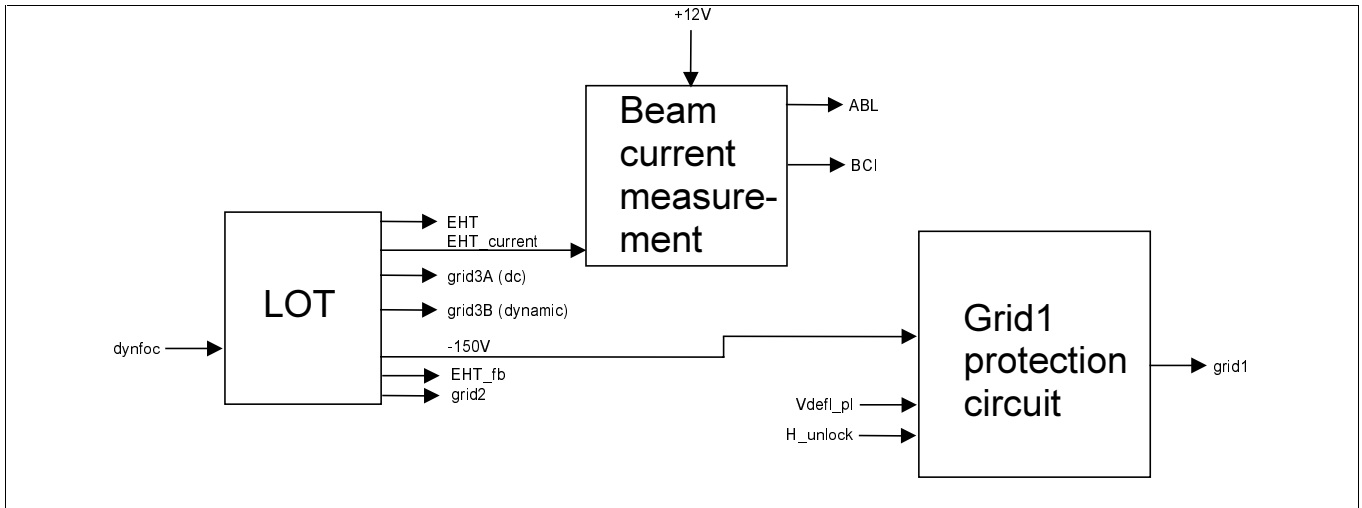

Figure 2-7 EHT supply block diagram

Signal name	Type	Connected with	Explanation
+12V	Supply	SMPS, Degauss Video board power Deflection controller Horizontal deflection output stage, EW modulator Grid1 protection circuit	
Dynfoc	Input	Dynamic focus amplifier	Amplified dynamic focus voltage
Vdefl_pl	Input	Vertical deflection	Indicates presence of vertical flyback pulses
H_unlock	Input	Deflection controller μC	Out of lock indication and fast blanking signal
EHT	Output	CRT	26kV
Grid3A(dc)	Output	CRT	Static x focus
Grid3B(dynamic)	Output	CRT	Static y and dynamic H+V focus
ABL	Output	Video processor	Automatic beam current limiter if EHT current is too high
Grid1	Output	CRT	Grid 1 voltage and also used for spot suppression

Grid2	Output	CRT	Grid 2 voltage
BCI	Output	Deflection controller	Beam current information

The high voltage transformer is combined with the horizontal deflection. The EHT voltage is stabilised via the B+ control stage. Also the beam (=anode) current is measured and fed back to pin HSMOD of the deflection controller to stabilise the horizontal size via the EW modulator (see section 2.3). This beam current measurement is also used for beam current limiting, in this way protecting the high voltage transformer and picture tube against too high beam currents. When the deflection controller is out of lock or the vertical deflection is not working properly, the grid 1 voltage is switched to $-150V$. This means that the spot is suppressed, so no picture tube burn-in occurs. The $-150V$ is an extra rectified winding on the high voltage transformer.

2.5 Vertical deflection output stage

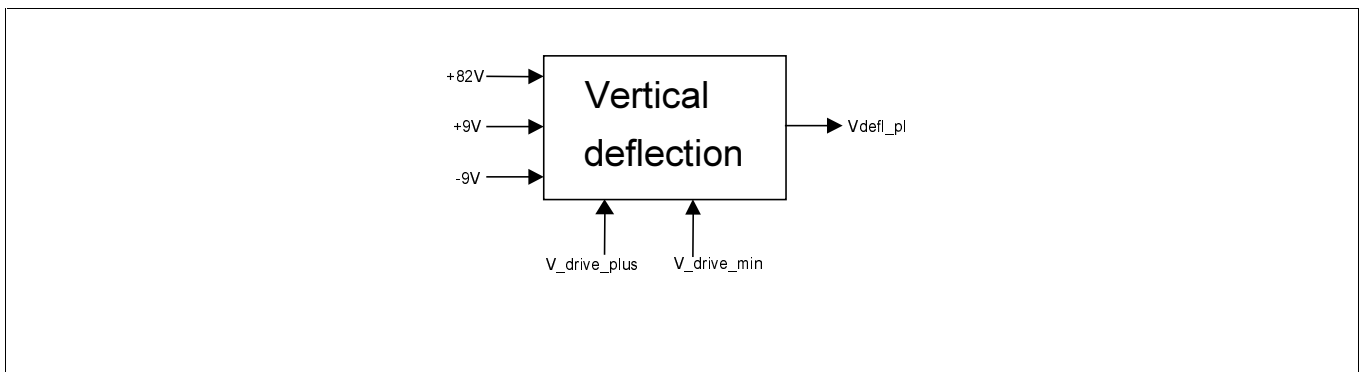

Figure 2-8 Vertical deflection output stage block diagram

Signal name	Type	Connected with	Explanation
+82V	Supply	SMPS, video output	This 82V is locally stabilised to 47V
+9V	Supply	SMPS, Rotation	Positive supply voltage
-9V	Supply	SMPS, Rotation Heater current	Negative supply voltage (substrate ground)
V_drive_plus, V_drive_min	Input	Deflection controller	Differential sawtooth current input for vertical deflection
Vdefl_pl	Output	Grid1 protection circuit	Indicates presence of vertical flyback pulses

The TDA4863J is a half bridge vertical booster for use in vertical deflection systems for frame frequencies up to 200 Hz. The TDA4863J needs a separate flyback supply voltage. This gives the designer the advantage that all supply voltages can be independently chosen for minimum power consumption and optimum flyback time. The circuit provides differential voltage input stages and fits well with the TDA485X / TDA484X monitor deflection controller family.

At the input of the circuit differential input currents are converted to differential input voltages by means of resistors.

Features:

- Power amplifier with differential voltage inputs,
- Output current up to 3 A (peak-to-peak value),
- Output stage with thermal and SOAR protection,
- Deflection frequency up to 200 Hz,
- Excellent linearity,
- Low component count,
- Easy interfacing for voltage or current drive,
- Smaller package,
- Reduced pin count.

For more detailed information see **AN00040** *Vertical booster TDA4863*.

2.6 Dynamic focus amplifier

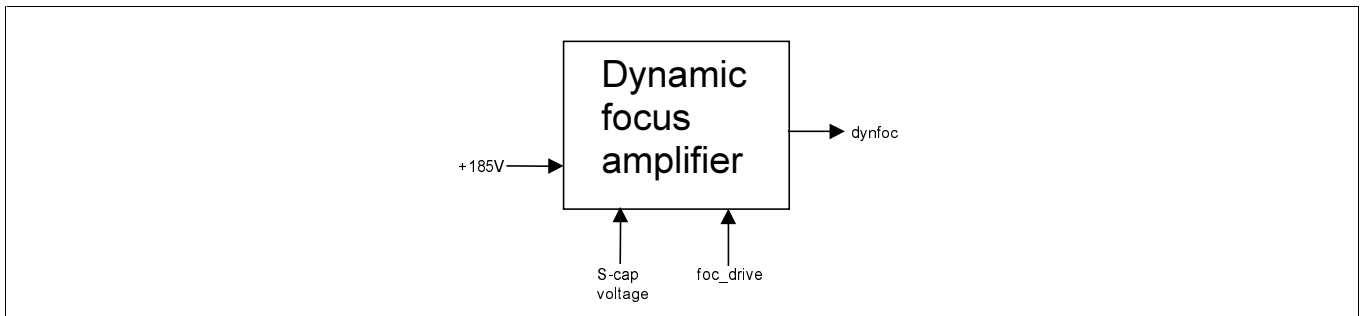

Figure 2-9 Dynamic focus amplifier block diagram

Signal name	Type	Connected with	Explanation
+185V	Supply	SMPS, horizontal deflection output stage, DC restore	
Foc_drive	Input	Deflection controller	Vertical dynamic focus drive voltage
S-cap voltage	Input	Horizontal deflection output stage	Voltage across the linearity capacitors
Dynfoc	Output	Line output transformer	Amplified dynamic focus voltage

The dynamic focus waveform consists of a horizontal parabola and a vertical parabola. The horizontal parabola is made by a voltage transformer which amplifies the voltage over the linearity capacitors (=S-cap's). The vertical focus parabola is made by the deflection controller and is amplified by a one-transistor circuit.

2.7 Rotation

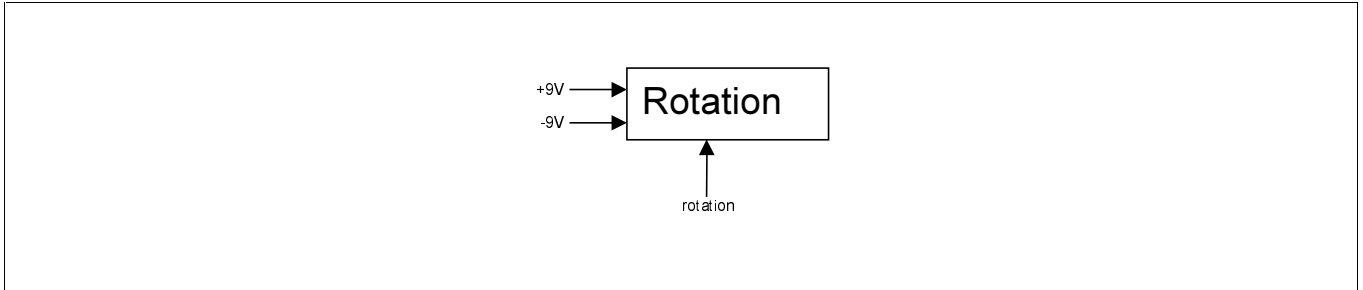

Figure 2-10 Rotation block diagram

Signal name	Type	Connected with	Explanation
+9V	Supply	SMPS, Vertical deflection	
-9V	Supply	SMPS, Vertical deflection, Heater current	
Rotation	Input	μC	Rotation/tilt

The rotation circuit consists of an inverting voltage amplifier. The rotation is adjusted via the micro-controller. There is no north-south (=vertical trapezium) correction.

2.8 Video

2.8.1 Power

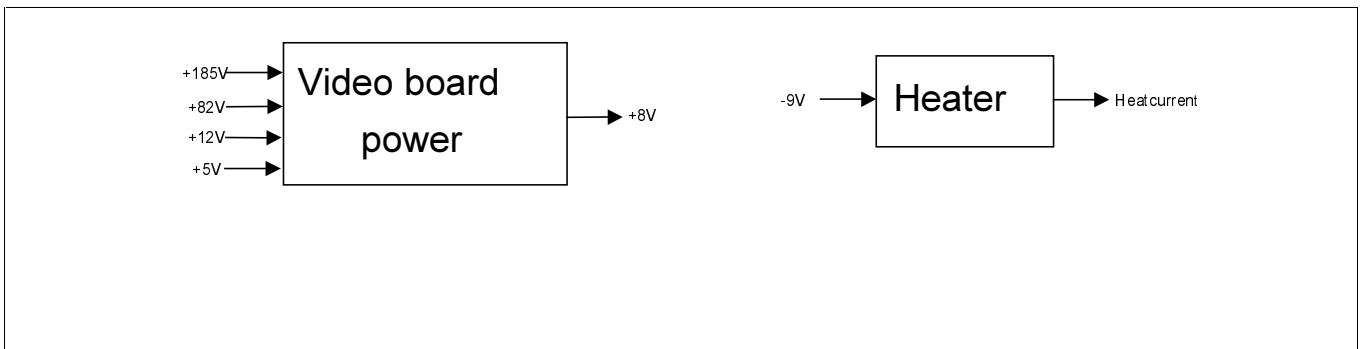

Figure 2-11 Video board power block diagram

Signal name	Type	Connected with	Explanation
+12V	Supply	SMPS, Degauss Deflection controller, Horizontal deflection output stage, EW modulator Beam current measurement Grid1 protection circuit	

+8V	Supply	Video processor, DC restoration circuit, Video output	Locally stabilised out of +12V
+82V	Supply	SMPS, Vertical deflection	
+5V	Supply	SMPS, μ C, EEPROM, OSD generator	
+185V	Supply	SMPS, horizontal deflection output stage, DC restoration, Dynamic focus amplifier	
-9V	Supply	SMPS, Vertical deflection, Rotation, Heater current	Heater supply

The heater supply of $-9V$ is fed to the heater filament via a series resistor. This resistor has a value such that the current through the heater filament is 309 mA.

2.8.2 Processing

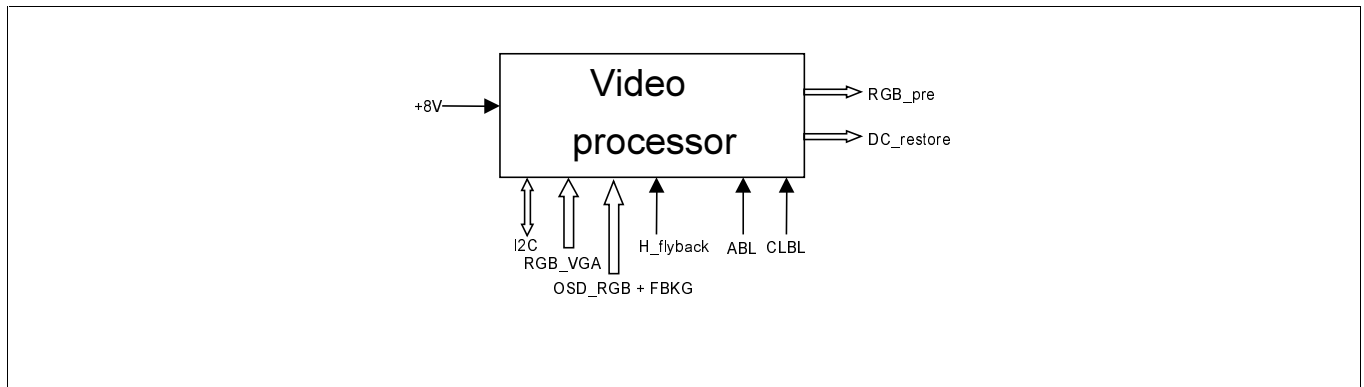

Figure 2-12 Video processing block diagram

Signal name	Type	Connected with	Explanation
+8V	Supply	DC restoration, Video output	Stabilised out of +12V
I2C	I/O	Deflection controller EEPROM Micro processor OSD generator	Inter IC Communication bus
RGB_VGA	Input	VGA connector	RGB input terminated with 75 ohm
OSD_RGB+FBKG	Input	OSD generator	OSD video information
H_flyback	Input	Horizontal deflection output stage, Deflection controller, OSD generator	Horizontal flyback signal used as output blanking signal
ABL	Input	Beam current measurement	Beam current limiting if EHT current is too high

CLBL	Input	Deflection controller	Two-level sandcastle pulse. Upper level is video clamping. Lower level is vertical blanking pulse.
RGB_pre	Output	Video booster	Processed RGB signals
DC_restore	Output	Video booster	DAC outputs for black level restoration

TDA4887PS is a monolithic integrated RGB pre-amplifier for colour monitor systems (e.g. 15" and 17") with I²C-bus control and OSD. In addition to bus control, beam current limiting and contrast modulation are possible. The IC offers brightness control with grey scale tracking and without grey scale tracking for easy alignment. The signals are amplified in order to drive commonly used video modules or discrete solutions. Individual black level control with negative feedback from the cathode (DC coupling) or black level control with positive feedback and 3 DAC outputs for external cut-off control (AC coupling) is possible.

In this monitor the AC coupling mode with positive feedback is used and brightness is done in the signal path with grey scale tracking.

2.8.3 OSD

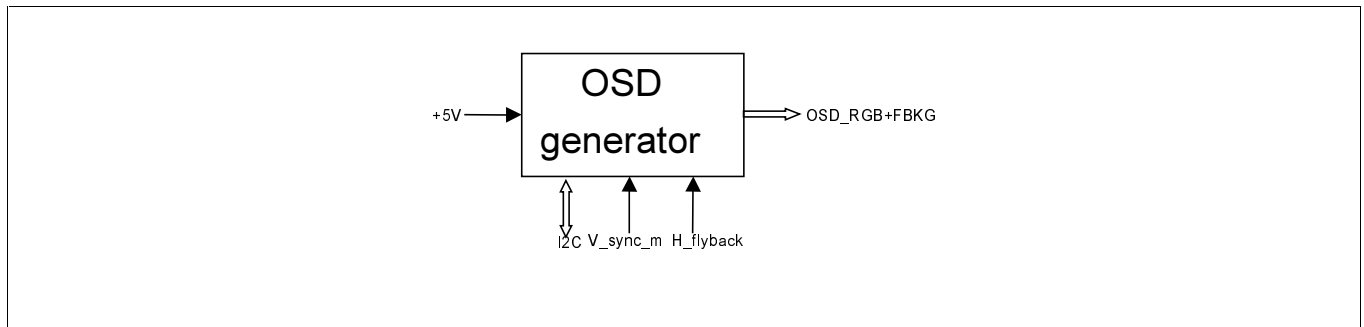

Figure 2-13 OSD generator block diagram

Signal name	Type	Connected with	Explanation
+5V	Supply	SMPS, μ C, EEPROM	Stabilised out of +12V
I2C	I/O	Deflection controller EEPROM Micro processor Video processor	Inter IC Communication bus
V_sync_m	Input	μ C Deflection controller	Vertical sync processed by μ C
H_flyback	Input	Horizontal deflection output stage, Deflection controller Video processor	Horizontal flyback signal
OSD_RGB+FBKG	Output	Video processor	OSD video information

2.8.4 Output stage

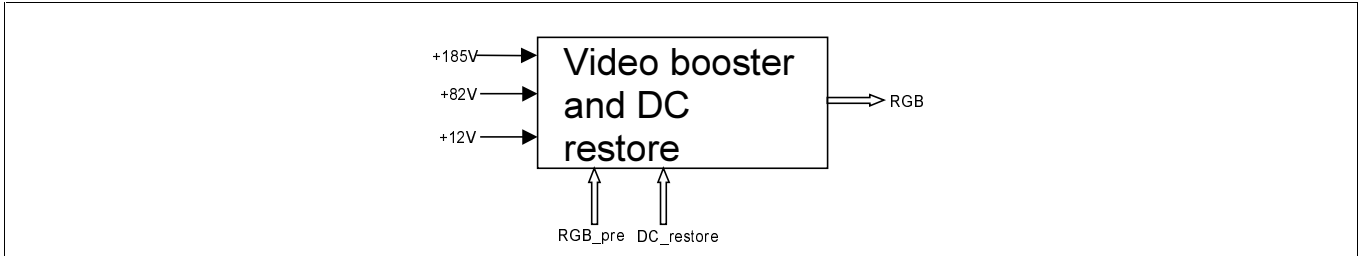

Figure 2-14 Output stage block diagram

Signal name	Type	Connected with	Explanation
+185V	Supply	SMPS, Horizontal deflection output stage, Dynamic focus amplifier	Supply voltage for DC restore circuit
+12V	Supply	SMPS, Degauss Deflection controller, Horizontal deflection output stage, EW modulator Beam current measurement Grid1 protection circuit	
+82V	Supply	SMPS, Vertical deflection	
RGB_pre	Input	Video processor	Processed RGB signals
DC_restore	Input	Video processor	Blacklevels
RGB	Out	CRT	Amplified, inverted & DC restored video signal

The output consists of an AC coupled class A monolithic video booster and DC restoration circuit.

2.8.5 CRT

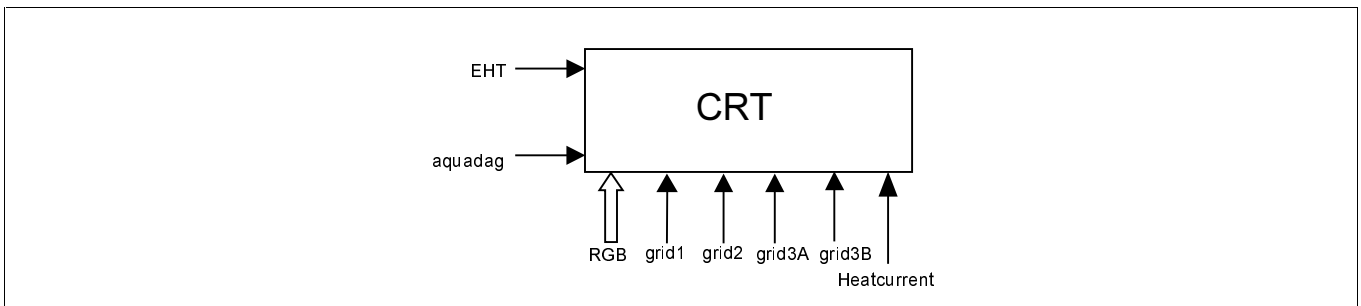

Figure 2-15 CRT block diagram

Signal name	Type	Connected with	Explanation
EHT	Supply	Line output transformer	26kV
Aquadag	Ground	Ground	Ground

RGB	Input	Video booster and DC restore	Amplified, inverted & processed video signal including OSD
Grid1	Input	Grid 1 protection circuit	Grid 1 voltage and also used for spot suppression
Grid2	Input	Line output transformer	Grid 2 voltage
Grid3A	Input	Line output transformer	Static focus x voltage
Grid3B	Input	Line output transformer	Static focus y and dynamic horizontal + vertical focus voltage
Heatcurrent	Input	-9 Supply voltage	Heater current.

Picture tube M41EHN323X160/G341BA:

High resolution; higher pixel density possible up to 1280x1024 pixels (non-interlaced) displayable conforms to ISO 9241 with:	<ul style="list-style-type: none"> - high definition gun - 0.27 mm dot triplet pitch
High brightness and contrast:	<ul style="list-style-type: none"> - optimised black matrix process
Excellent white uniformity and colour purity	<ul style="list-style-type: none"> - invar shadow mask - axial 3-pin suspension - inner magnetic shielding
Accurate convergence and raster geometry	<ul style="list-style-type: none"> - double mussel coil technology - internal magnetostatic beam alignment - additional vertical symmetry adjustment for optional and easy convergence touch-up
Deflection coil data	<ul style="list-style-type: none"> - horizontal coil inductance = 180 μH - vertical coil resistance = 6.3 Ω - vertical coil inductance = 6.3 mH - maximum advised horizontal frequency = 66 kHz

3. SCHEMATICS

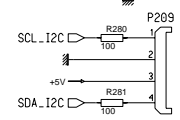
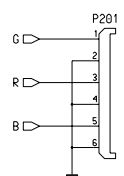
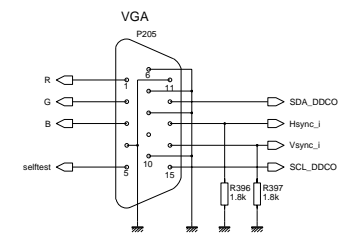
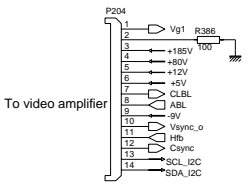
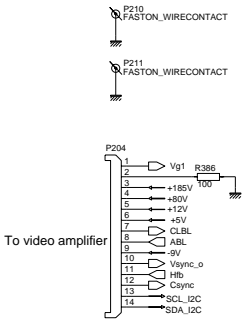
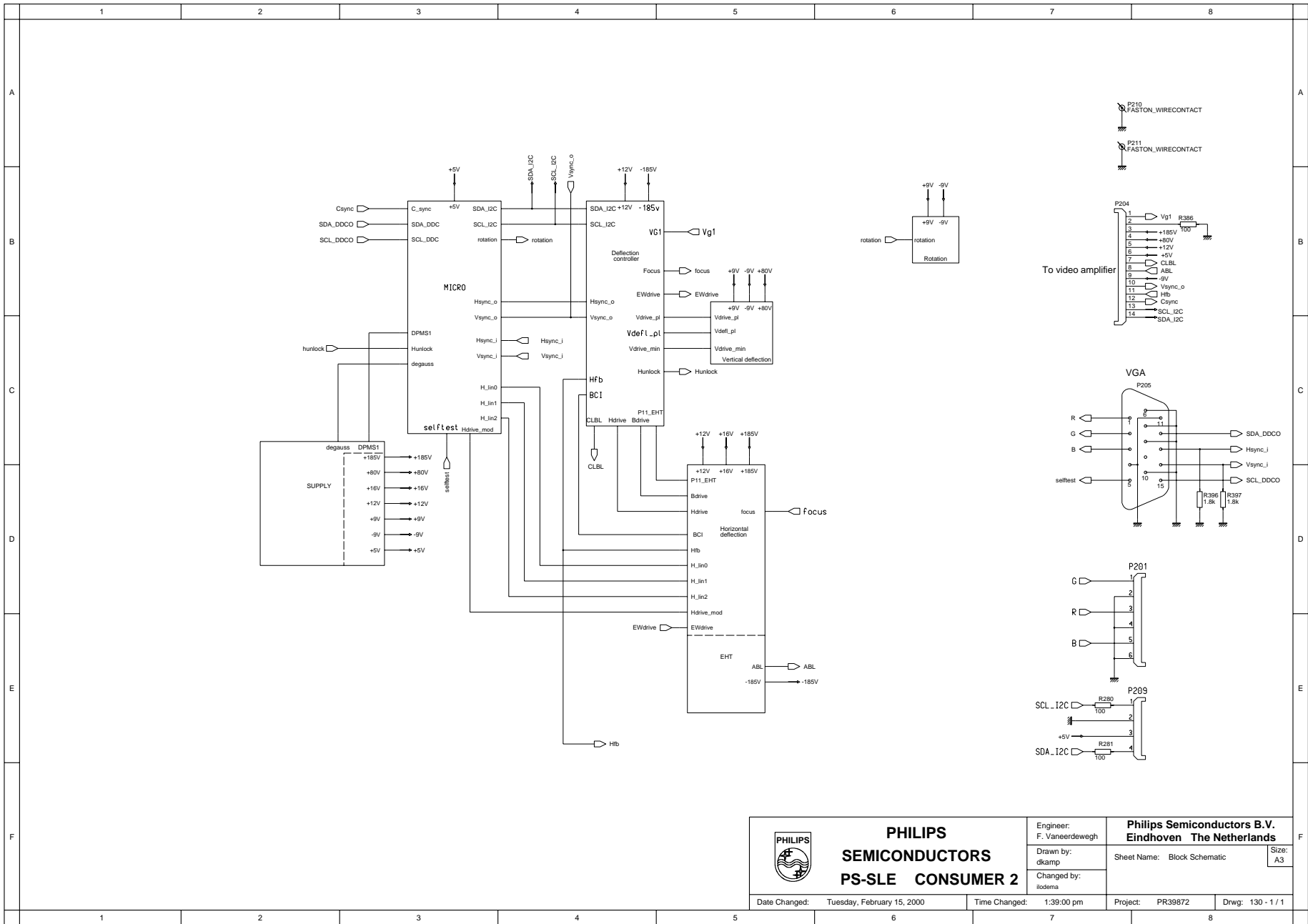

	PHILIPS SEMICONDUCTORS		Engineer: F. Vaneerdewegh		Philips Semiconductors B.V.	
	PS-SLE CONSUMER 2		Drawn by: dkamp		Eindhoven The Netherlands	
			Changed by: ilodema		Sheet Name: Block Schematic	
Date Changed: Tuesday, February 15, 2000		Time Changed: 1:39:00 pm		Project: PR39872		Size: A3
				Drwg: 130 - 1 / 1		

3.1 Switch Mode Power Supply

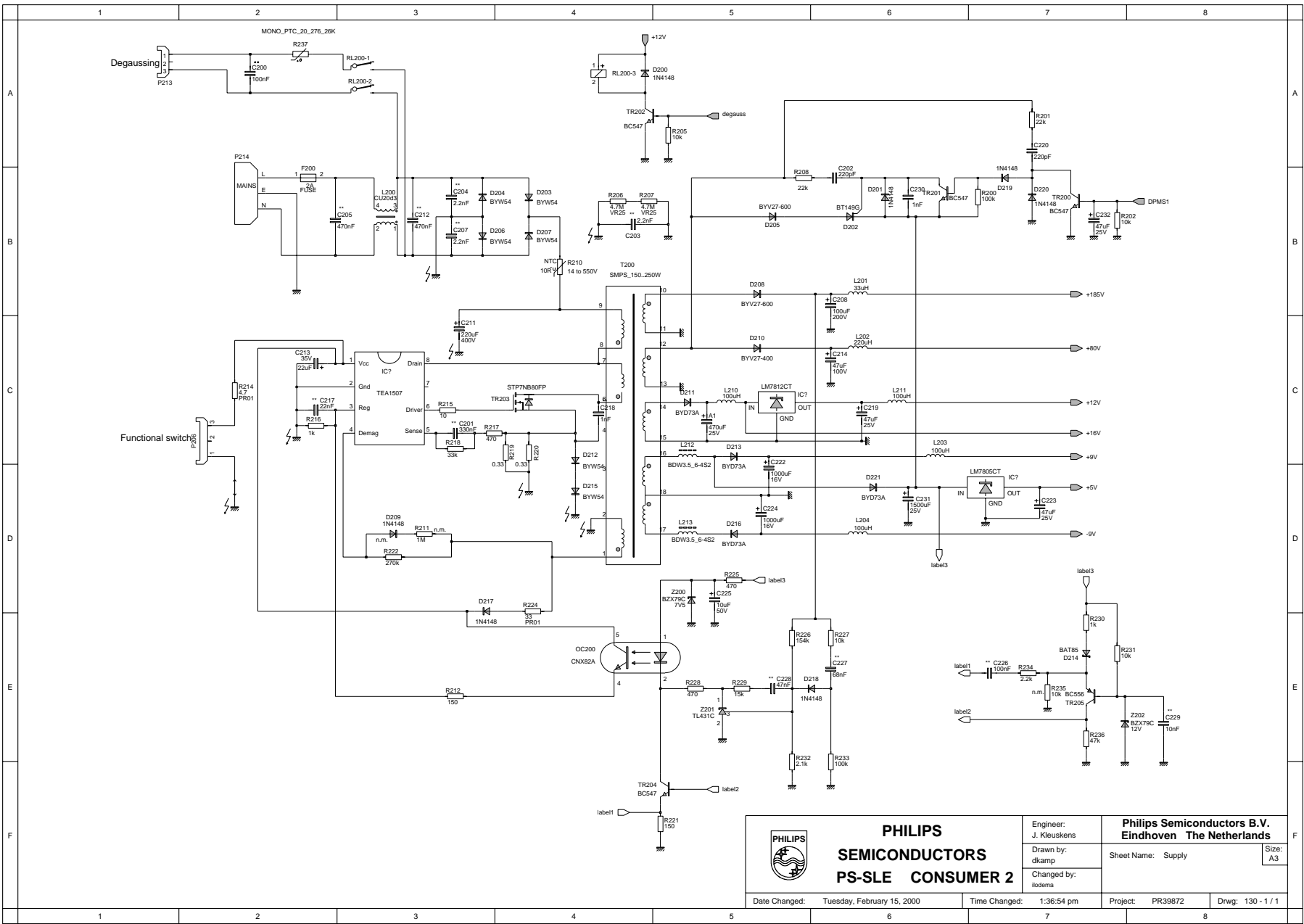

 <p>PHILIPS SEMICONDUCTORS PS-SLE CONSUMER 2</p>	<p>Engineer: J. Kleuskens</p>	<p>Philips Semiconductors B.V. Eindhoven The Netherlands</p>		
	<p>Drawn by: dkamp</p>	<p>Sheet Name: Supply</p>		<p>Size: A3</p>
<p>Changed by: Iodema</p>	<p>Date Changed: Tuesday, February 15, 2000</p>	<p>Time Changed: 1:36:54 pm</p>	<p>Project: PR39872</p>	<p>Drwg: 130 - 1 / 1</p>

3.2 Micro controller

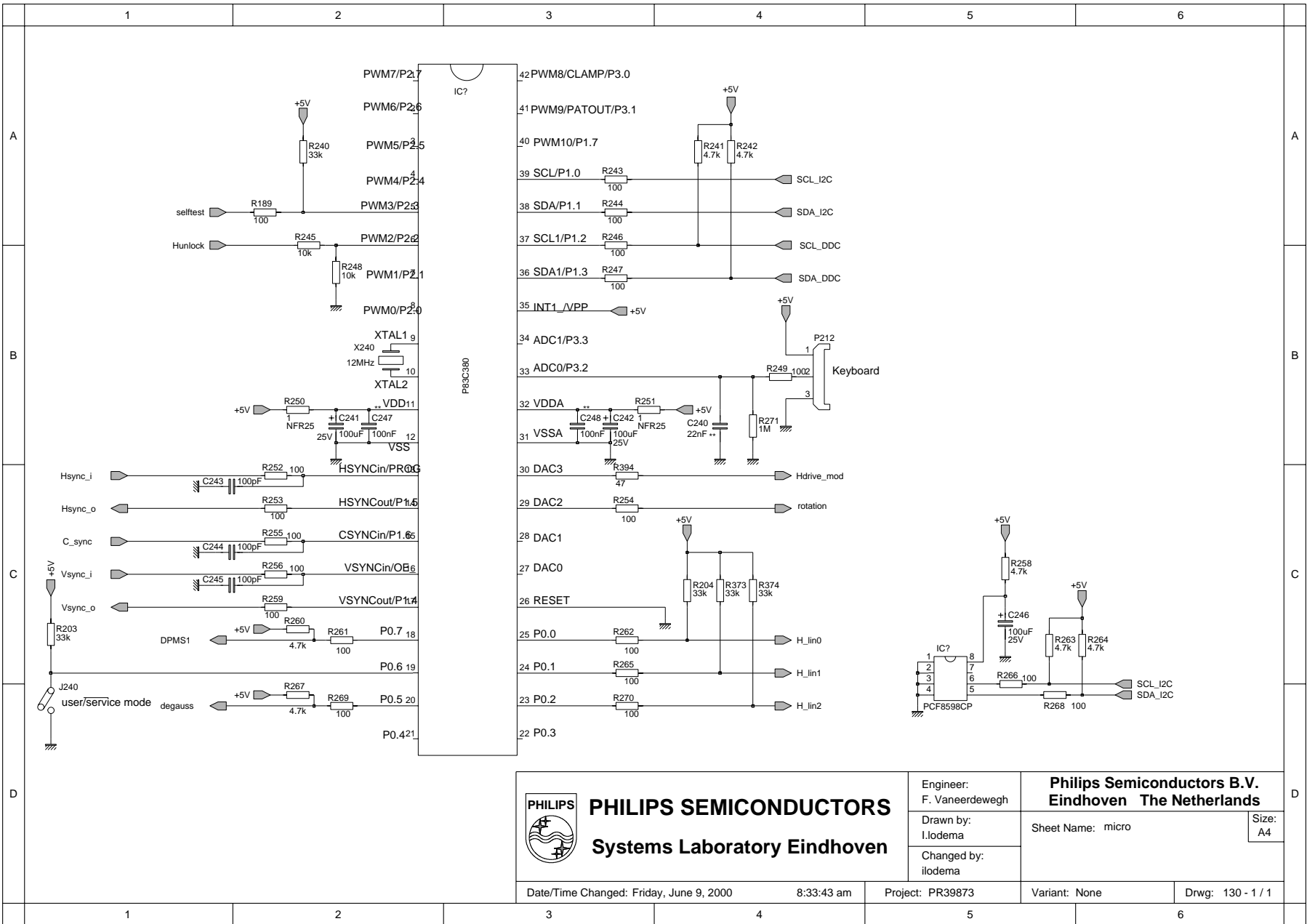

PHILIPS SEMICONDUCTORS
Systems Laboratory Eindhoven

Engineer:
F. Vaneerdewegh

Drawn by:
I.lodema

Changed by:
ilodema

Philips Semiconductors B.V.
Eindhoven The Netherlands

Sheet Name: micro

Size:
A4

Date/Time Changed: Friday, June 9, 2000

8:33:43 am

Project: PR39873

Variant: None

Drwg: 130 - 1 / 1

3.3 Deflection controller

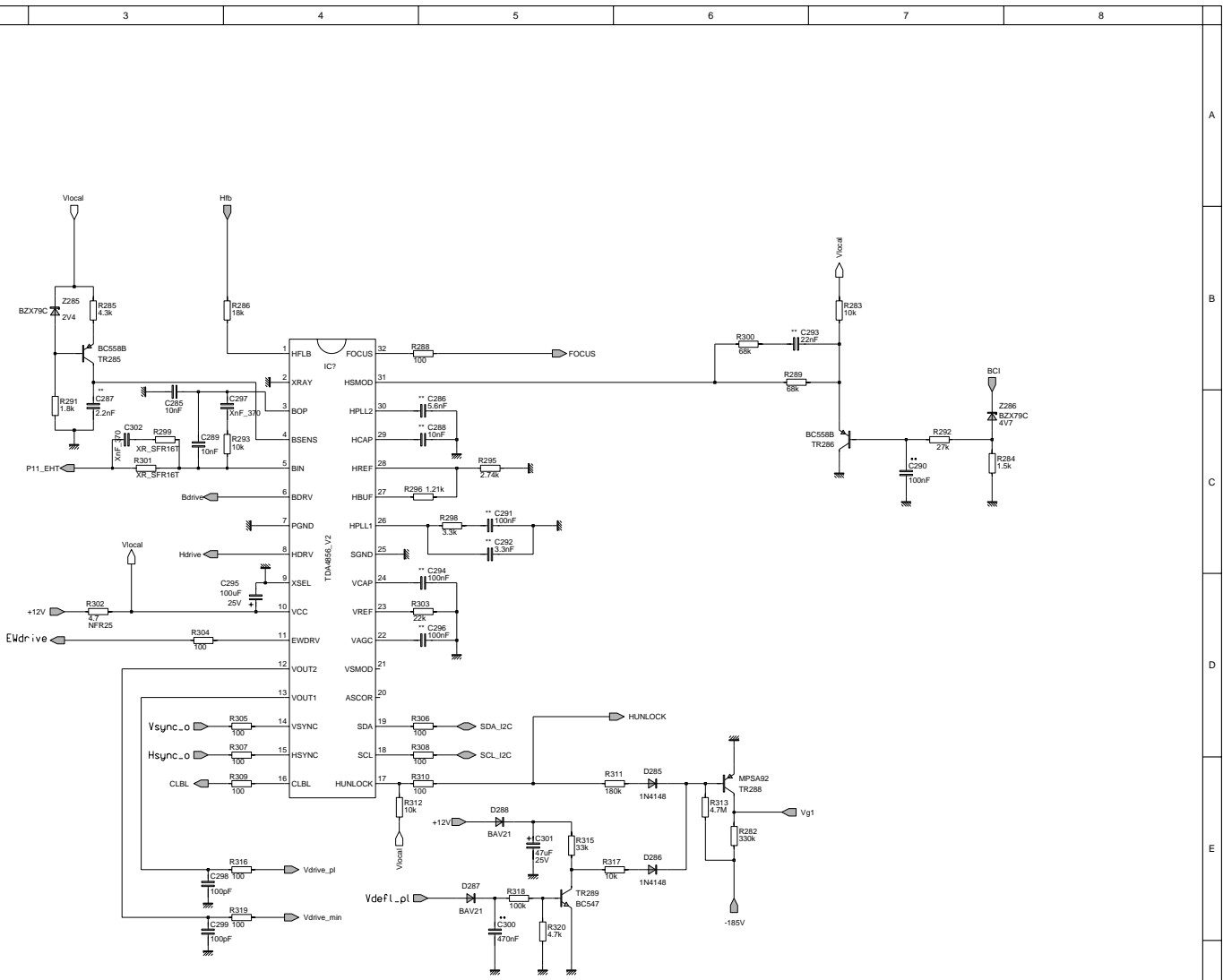

 <p>PHILIPS SEMICONDUCTORS PS-SLE CONSUMER 2</p>	<p>Engineer: F. Vaneerdewegh</p>	<p>Philips Semiconductors B.V. Eindhoven The Netherlands</p>
	<p>Drawn by: Iodema</p>	<p>Sheet Name: deflection_controller</p>
<p>Changed by: Iodema</p>	<p>Date/Time Changed: Tuesday, February 15, 2000 1:42:22 pm</p>	<p>Project: PR39872</p>
<p>Variant: None</p>	<p>Drwg: 130 - 1 / 1</p>	

3.4 Rotation circuit

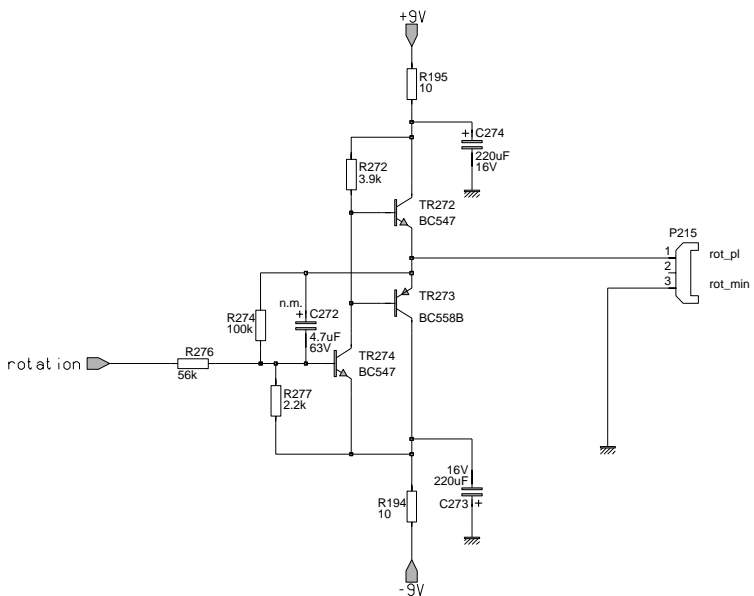

PHILIPS
SEMICONDUCTORS
PS-SLE CONSUMER 2

Engineer:
F. Vaneerdewegh

Drawn by:
dkamp

Changed by:
ilodema

Philips Semiconductors B.V.
Eindhoven The Netherlands

Sheet Name: Rotation circuit

Size:
A4

Date Changed: Wednesday, December 8, 1999

Time Changed: 9:31:32 am

Project: DESIGN

Drwg: 130 - 1 / 1

3.5 Horizontal deflection circuit

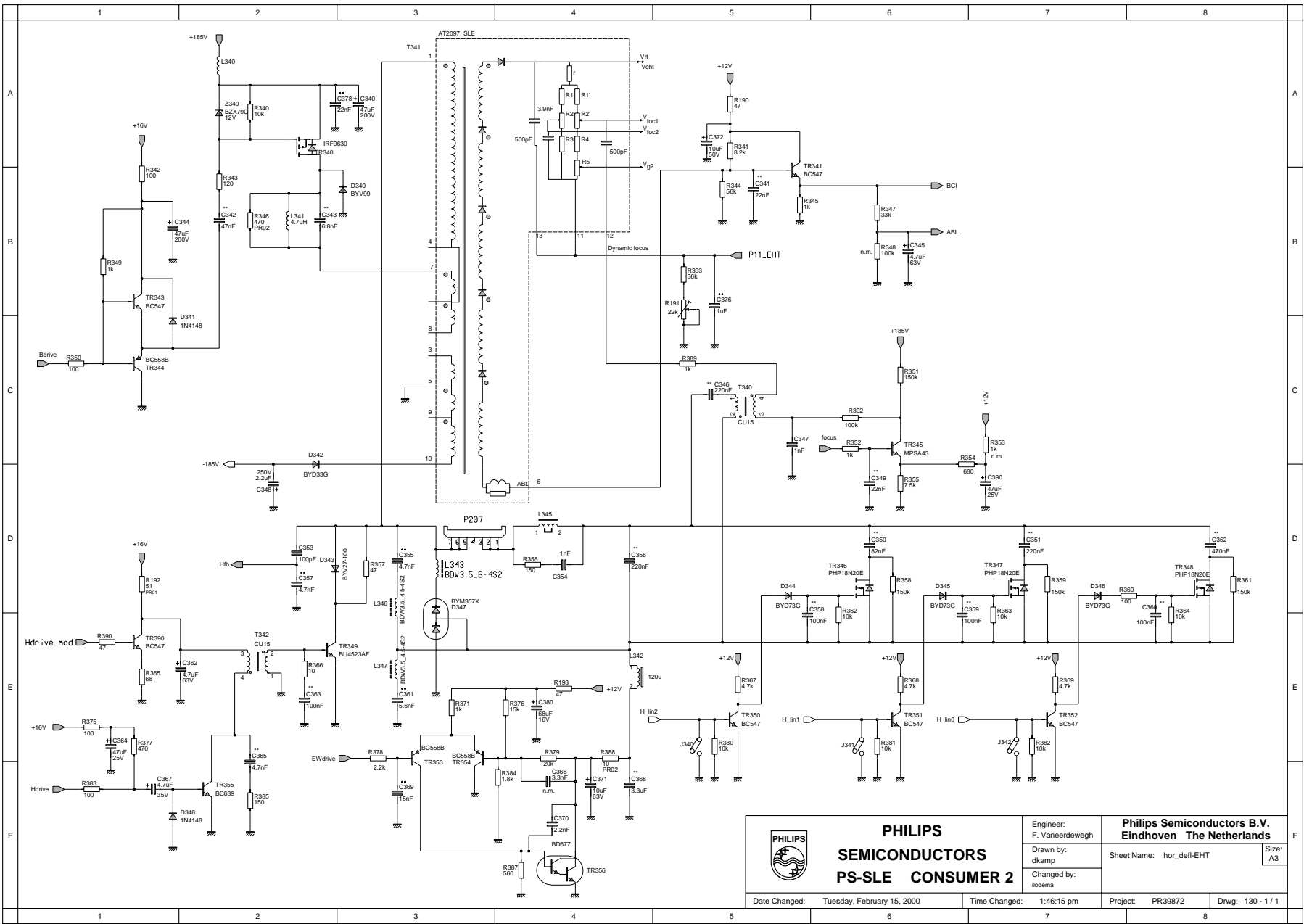

 PHILIPS SEMICONDUCTORS PS-SLE CONSUMER 2	Engineer: F. Vaneerdewegh	Philips Semiconductors B.V. Eindhoven The Netherlands
	Drawn by: dkamp	Sheet Name: hor_defl-EHT
Date Changed: Tuesday, February 15, 2000	Time Changed: 1:46:15 pm	Project: PR39872
		Drwg: 130 - 1 / 1

3.6 Vertical deflection circuit

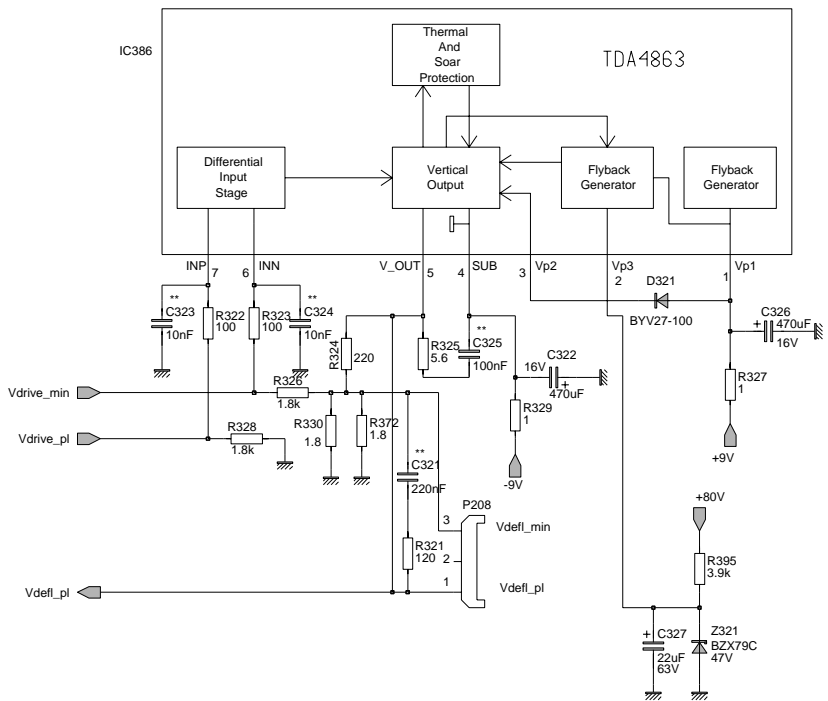

 PHILIPS SEMICONDUCTORS PS-SLE CONSUMER 2	Engineer: F. Vaneerdewegh	Philips Semiconductors B.V. Eindhoven The Netherlands	
	Drawn by: dkamp	Sheet Name: Vertical Deflection	Size: A4
	Changed by: iodema		
Date Changed: Tuesday, February 15, 2000	Time Changed: 1:43:51 pm	Project: PR39872	Drwg: 130 - 1 / 1

3.7 Video

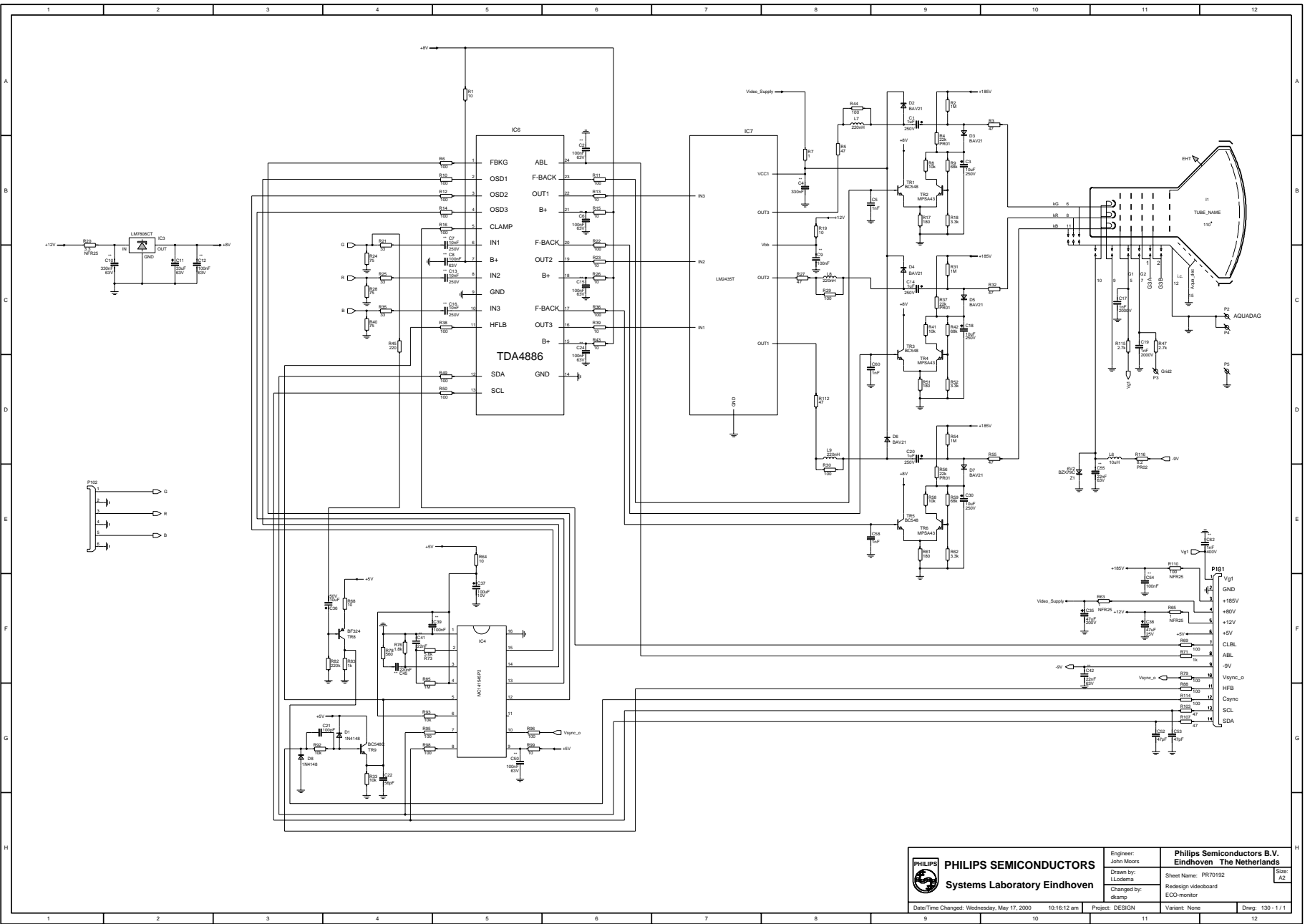

PHILIPS SEMICONDUCTORS
Systems Laboratory Eindhoven

Engineer: John Meers
 Drawn by: I.Lodema
 Changed by: dkamp
 Philips Semiconductors B.V.
 Eindhoven The Netherlands
 Sheet Name: PR70192
 Redesign videoboard
 ECO-Monitor
 Variant: None

Date/Time Changed: Wednesday, May 17, 2000 10:16:12 am
 Project: DESIGN
 Drawn: 130 - 1 / 1

4. BOARD COMPONENT PLACEMENT

4.1 Main board

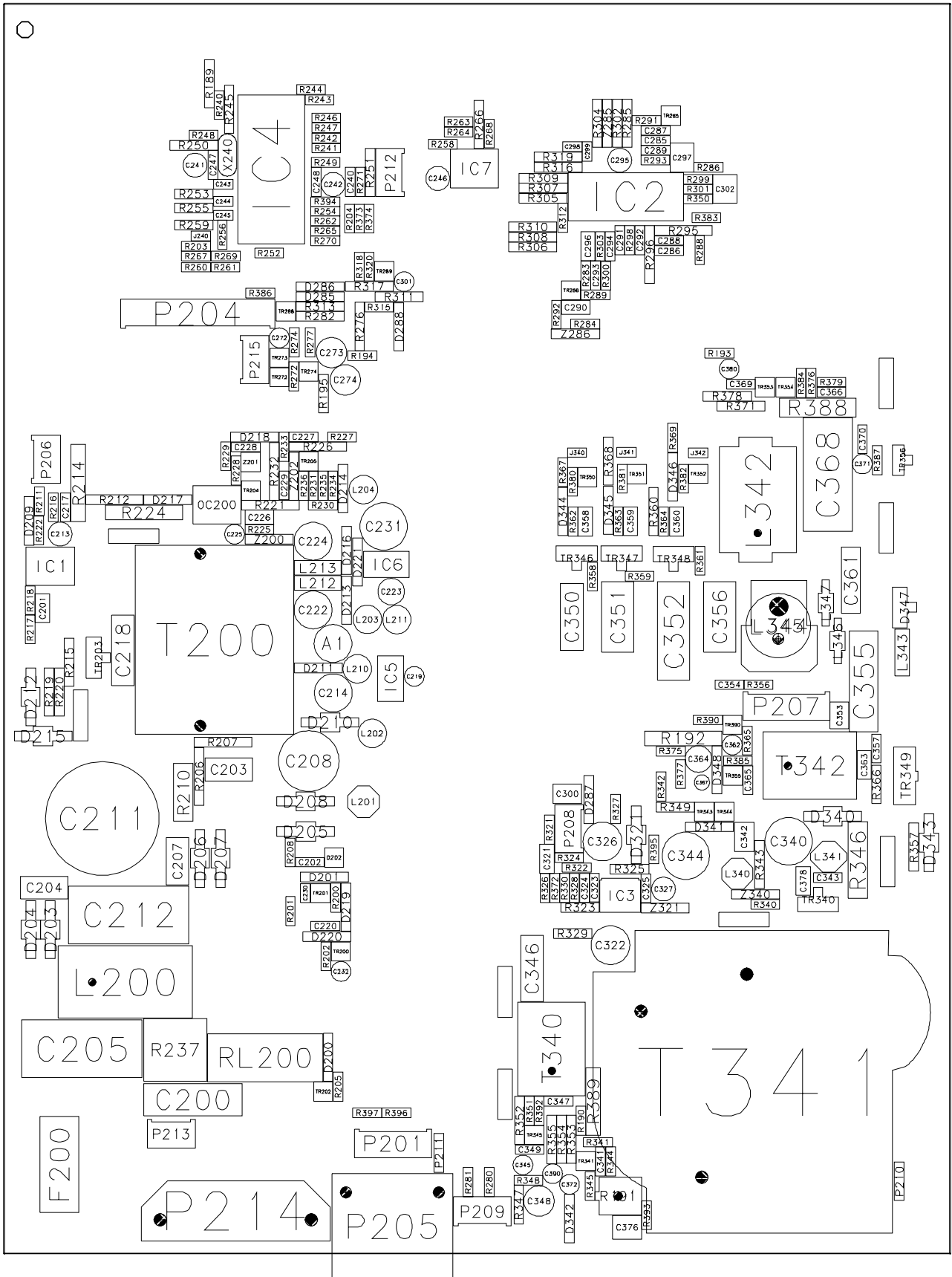

4.2 Video board

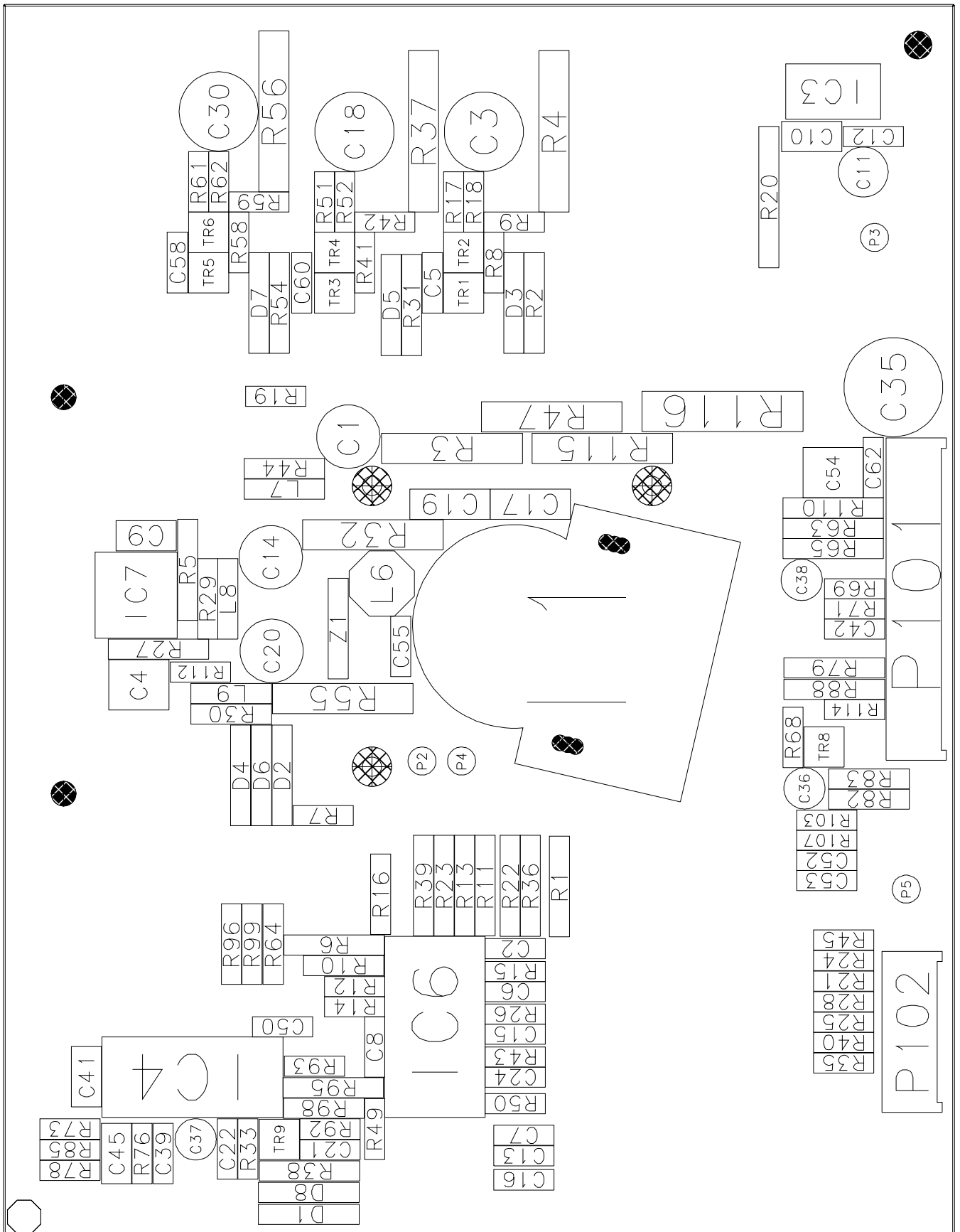

5. PCB LAYOUT

5.1 Main board

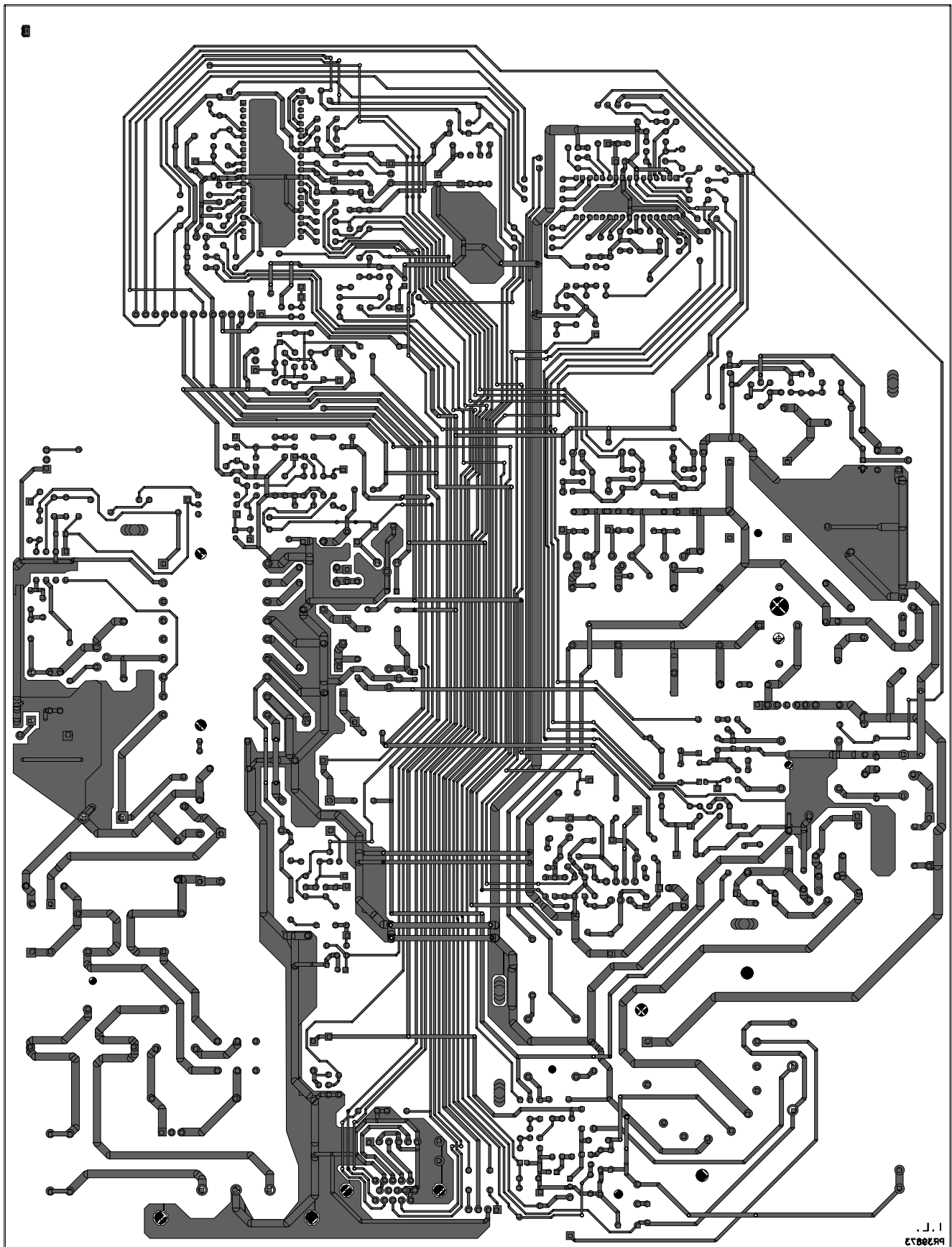

5.2 Video board

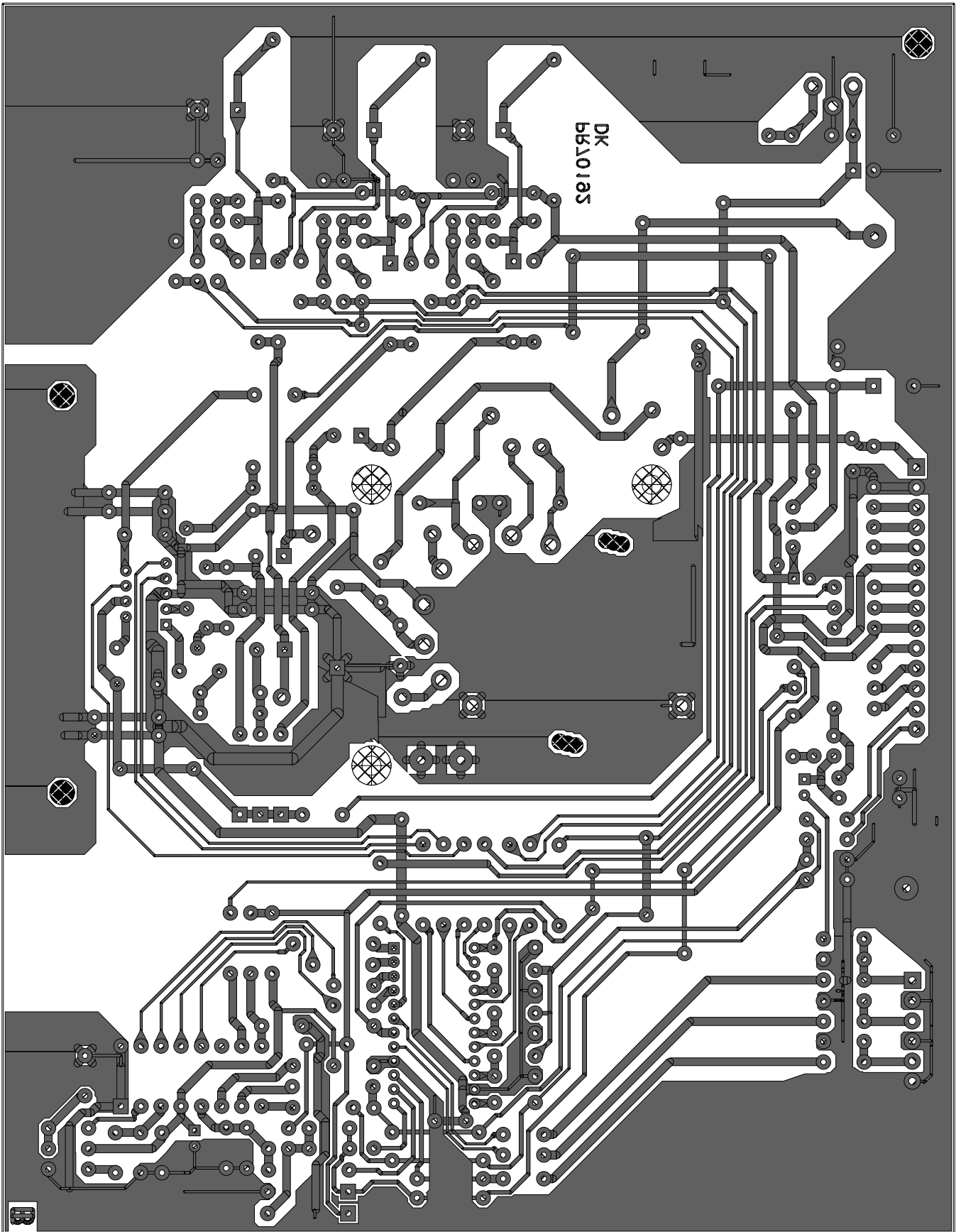

6. BILL OF MATERIALS**Bill of materials of SLE ECO monitor design.****Date:19 juni 2000****6.1 Main board**

REF.	PART_NO	COMPONENT	SERIES	RATING	TOL.	VENDOR
C200	2222-378-64104	100nF	MKP/MKP 378	630V	5%	BC
C201	2222-370-75334	330nF	MKT 370	63V	10%	BC
C202	2222-655-09221	220pF	C655	500V	10%	BC
C203	2222-336-60222	2.2nF	MKP 336_Y2	250V	20%	BC
C204	2222-336-60222	2.2nF	MKP 336_Y2	250V	20%	BC
C205	2222-336-10474	470nF	MKP 336_X1	275V	20%	BC
C207	2222-336-60222	2.2nF	MKP 336_Y2	250V	20%	BC
C208	2222-151-62101	100uF	RLH 151	200V	20%	BC
C209	2222-136-66471	470uF	RVI136	25V	20%	BC
C211	2222-057-36221	220uF	PSM-SI 057	400V	20%	BC
C212	2222-336-10474	470nF	MKP 336_X1	275V	20%	BC
C213	2222-134-50229	22uF	RLP5 134	35V	20%	BC
C214	2222-037-59479	47uF	RSM 037	100V	20%	BC
C217	2222-370-85223	22nF	MKT 370	100V	10%	BC
C218	2222-375-44102	1nF	KP/MKP 375	2000V	5%	BC
C219	2222-037-56479	n.m.	RSM 037	25V	20%	BC
C220	2222-655-09221	220pF	C655	500V	10%	BC
C222	2222-037-65102	1000uF	RSM 037	16V	20%	BC
C223	2222-097-56479	n.m.	RLP7 097	25V	20%	BC
C224	2222-037-65102	1000uF	RSM 037	16V	20%	BC
C225	2222-037-51109	10uF	RSM 037	50V	20%	BC
C226	2222-370-85104	100nF	MKT 370	100V	10%	BC
C227	2222-370-75683	68nF	MKT 370	63V	10%	BC
C228	2222-370-85473	47nF	MKT 370	100V	10%	BC
C229	2222-370-76103	10nF	MKT 370	250V	5%	BC
C230	2222-630-09102	1nF	C630	100V	10%	BC
C231	2222-037-66152	1500uF	RSM 037	25V	20%	BC
C232	2222-037-56479	47uF	RSM 037	25V	20%	BC
C240	2222-370-85223	22nF	MKT 370	100V	10%	BC
C241	2222-037-90047	100uF	RSM 037	25V	20%	BC
C242	2222-037-90047	100uF	RSM 037	25V	20%	BC
C243	2222-681-10101	100pF	C631-NP0	100V	2%	BC
C244	2222-681-10101	100pF	C631-NP0	100V	2%	BC
C245	2222-681-10101	100pF	C631-NP0	100V	2%	BC
C246	2222-037-90047	100uF	RSM 037	25V	20%	BC
C247	2222-370-75104	100nF	MKT 370	63V	10%	BC
C248	2222-370-75104	100nF	MKT 370	63V	10%	BC
C272	2222-037-58478	n.m.	RSM 037	63V	20%	BC
C273	2222-037-65221	220uF	RSM 037	16V	20%	BC
C274	2222-037-65221	220uF	RSM 037	16V	20%	BC
C285	2222-629-09103	10nF	C629	63V	-20+80%	BC
C286	2222-370-35562	5.6nF	MKT 370	250V	10%	BC
C287	2222-370-52222	2.2nF	MKT 370	400V	5%	BC
C288	2222-370-76103	10nF	MKT 370	250V	5%	BC
C289	2222-629-09103	10nF	C629	63V	-20+80%	BC
C290	2222-370-85104	100nF	MKT 370	100V	10%	BC
C291	2222-370-75104	100nF	MKT 370	63V	10%	BC
C292	2222-370-65332	3.3nF	MKT 370	400V	10%	BC
C293	2222-370-85223	22nF	MKT 370	100V	10%	BC
C294	2222-370-76104	100nF	MKT 370	63V	5%	BC
C295	2222-037-90047	100uF	RSM 037	25V	20%	BC
C296	2222-370-85104	100nF	MKT 370	100V	10%	BC

REF.	PART_NO	COMPONENT	SERIES	RATING	TOL.	VENDOR
C297	2222-370-75XXX	XnF_370	MKT 370	63V	10%	BC
C298	2222-681-10101	100pF	C631-NP0	100V	2%	BC
C299	2222-681-10101	100pF	C631-NP0	100V	2%	BC
C300	2222-370-75474	470nF	MKT 370	63V	10%	BC
C301	2222-037-56479	47uF	RSM 037	25V	20%	BC
C302	2222-370-75XXX	XnF_370	MKT 370	63V	10%	BC
C321	2222-370-75224	220nF	MKT 370	63V	10%	BC
C322	2222-037-65471	470uF	RSM 037	16V	20%	BC
C323	2222-370-35103	10nF	MKT 370	250V	10%	BC
C324	2222-370-35103	10nF	MKT 370	250V	10%	BC
C325	2222-370-75104	100nF	MKT 370	63V	10%	BC
C326	2222-037-65471	470uF	RSM 037	16V	20%	BC
C327	2222-037-58229	22uF	RSM 037	63V	20%	BC
C340	2222-151-62479	47uF	RLH 151	200V	20%	BC
C341	2222-370-85223	22nF	MKT 370	100V	10%	BC
C342	2222-370-35473	47nF	MKT 370	250V	10%	BC
C343	2222-370-35682	6.8nF	MKT 370	250V	10%	BC
C344	2222-151-62479	47uF	RLH 151	200V	20%	BC
C345	2222-037-58478	4.7uF	RSM 037	63V	20%	BC
C346	2222-379-44224	220nF	MKP 379	250V	5%	BC
C347	2222-655-09102	1nF	C655	500V	10%	BC
C348	2222-044-90015	2.2uF	RSH 044	250V	20%	BC
C349	2222-370-85223	22nF	MKT 370	100V	10%	BC
C350	2222-379-54823	82nF	MKP 379	400V	5%	BC
C351	2222-379-54224	220nF	MKP 379	400V	5%	BC
C352	2222-379-54474	470nF	MKP 379	400V	5%	BC
C353	DE0405-B-101K2K	100pF	Hi_voltage	2000V	10%	muRata
C354	2222-655-09102	1nF	C655	500V	10%	BC
C355	2222-376-92472	4.7nF	KP/MMKP 376	2000V	5%	BC
C356	2222-379-54224	220nF	MKP 379	400V	5%	BC
C357	2222-370-65472	4.7nF	MKT 370	400V	10%	BC
C358	2222-370-85104	100nF	MKT 370	100V	10%	BC
C359	2222-370-85104	100nF	MKT 370	100V	10%	BC
C360	2222-370-85104	100nF	MKT 370	100V	10%	BC
C361	2222-376-72562	5.6nF	KP/MMKP 376	1000V	5%	BC
C362	2222-037-58478	4.7uF	RSM 037	63V	20%	BC
C363	2222-370-85104	100nF	MKT 370	100V	10%	BC
C364	2222-097-56479	47uF	RLP7 097	25V	20%	BC
C365	2222-370-35472	4.7nF	MKT 370	250V	10%	BC
C366	2222-630-09332	3.3nF	C630	100V	10%	BC
C367	2222-097-50478	4.7uF	RLP7 097	35V	20%	BC
C368	2222-479-34335	3.3uF	MKP 479	160V	5%	BC
C369	2222-370-85153	15nF	MKT 370	100V	10%	BC
C370	2222-630-09222	2.2nF	C630	100V	10%	BC
C371	2222-037-58109	10uF	RSM 037	63V	20%	BC
C372	2222-037-51109	10uF	RSM 037	50V	20%	BC
C376	2222-370-75105	1uF	MKT 370	63V	10%	BC
C378	2222-370-35223	22nF	MKT 370	250V	10%	BC
C380	2222-037-65689	68uF	RSM 037	16V	20%	BC
C390	2222-037-56479	47uF	RSM 037	25V	20%	BC
D200	9330-839-90153	1N4148	Gen_Purpose	75V	-	PHILIPS
D201	9330-839-90153	1N4148	Gen_Purpose	75V	-	PHILIPS
D202	9333-984-40112	BT149G	Thyr_Triac	600G	-	PHILIPS
D203	9333-636-10113	BYW54	Rectifier	600V	-	PHILIPS
D204	9333-636-10113	BYW54	Rectifier	600V	-	PHILIPS
D205	9340-418-70113	BYV27-600	Rectifier	600V	-	PHILIPS
D206	9333-636-10113	BYW54	Rectifier	600V	-	PHILIPS
D207	9333-636-10113	BYW54	Rectifier	600V	-	PHILIPS
D208	9340-418-70113	BYV27-600	Rectifier	600V	-	PHILIPS

REF.	PART_NO	COMPONENT	SERIES	RATING	TOL.	VENDOR
D209	9330-839-90153	n.m.	Gen_Purpose	75V	-	PHILIPS
D210	9340-366-90133	BYV27-400	Rectifier	400V	-	PHILIPS
D211	9337-537-40113	BYD73A	Rectifier	50V	-	PHILIPS
D212	9333-636-10113	BYW54	Rectifier	600V	-	PHILIPS
D213	9337-537-40113	BYD73A	Rectifier	50V	-	PHILIPS
D214	9336-247-60112	BAT85	Schottky	-	-	PHILIPS
D215	9333-636-10113	BYW54	Rectifier	600V	-	PHILIPS
D216	9337-537-40113	BYD73A	Rectifier	50V	-	PHILIPS
D217	9330-839-90153	1N4148	Gen_Purpose	75V	-	PHILIPS
D218	9330-839-90153	1N4148	Gen_Purpose	75V	-	PHILIPS
D219	9330-839-90153	1N4148	Gen_Purpose	75V	-	PHILIPS
D220	9330-839-90153	1N4148	Gen_Purpose	75V	-	PHILIPS
D221	9337-537-40113	BYD73A	Rectifier	50V	-	PHILIPS
D285	9330-839-90153	1N4148	Gen_Purpose	75V	-	PHILIPS
D286	9330-839-90153	1N4148	Gen_Purpose	75V	-	PHILIPS
D287	9331-892-10153	BAV21	Gen_Purpose	-	-	PHILIPS
D288	9331-892-10153	BAV21	Gen_Purpose	-	-	PHILIPS
D321	9335-435-00133	BYV27-100	Rectifier	100V	-	PHILIPS
D340	9340-215-20113	BYV99	Rectifier	-	-	PHILIPS
D341	9330-839-90153	1N4148	Gen_Purpose	75V	-	PHILIPS
D342	9337-234-10113	BYD33G	Rectifier	400V	-	PHILIPS
D343	9335-435-00133	BYV27-100	Rectifier	100V	-	PHILIPS
D344	9337-538-00113	BYD73G	Rectifier	400V	-	PHILIPS
D345	9337-538-00113	BYD73G	Rectifier	400V	-	PHILIPS
D346	9337-538-00113	BYD73G	Rectifier	400V	-	PHILIPS
D347	9340-560-30127	BYM357X	Gen_Purpose	-	-	PHILIPS
D348	9330-839-90153	1N4148	Gen_Purpose	75V	-	PHILIPS
F200	2412-086-28196	2A	FAST	-	-	PHILIPS
IC1	PN-TEA1507	TEA1507	SMPS controller	-	-	PHILIPS
IC2	9352-674-52112	TDA4856_V3	Deflection contr.	-	-	PHILIPS
IC3	9352-637-54112	TDA4863J_V1	Vertical booster	-	-	PHILIPS
IC4	PN-P83C380	P83C380	Microprocessor	-	-	PHILIPS
IC5	PN-LM7812CT	LM7812CT	Stab_Pos	-	-	NS
IC6	PN-LM7805CT	LM7805CT	Stab_Pos	-	-	NS
IC7	9350-646-00112	PCF8598CP	EEPROMs	-	-	PHILIPS
J240	2422-021-98731	JUMPER_2p	print_switch	-	-	PHILIPS
J340	2422-021-98731	JUMPER_2p	print_switch	-	-	PHILIPS
J341	2422-021-98731	JUMPER_2p	print_switch	-	-	PHILIPS
J342	2422-021-98731	JUMPER_2p	print_switch	-	-	PHILIPS
L200	3112-338-31902	CU20d3	Chokes	-	-	PHILIPS
L201	TSL0709-33K1R9	33uH	TSL0709	-	10%	TDK
L202	TSL0709RA- 221KR44	220uH	TSL0709	-	20%	TDK
L203	TSL0709-101KR66	100uH	TSL0709	-	20%	TDK
L204	TSL0709-101KR66	100uH	TSL0709	-	20%	TDK
L210	TSL0709-101KR66	100uH	TSL0709	-	20%	TDK
L211	TSL0709-101KR66	100uH	TSL0709	-	20%	TDK
L212	4330-030-38741	BDW3.5_6-4S2	BDW	-	-	PHILIPS
L213	4330-030-38741	BDW3.5_6-4S2	BDW	-	-	PHILIPS
L340	TSL0709-33K1R9	68uH	TSL0709	-	10%	TDK
L341	TSL0709-4R7M2R6	4.7uH	TSL0709	-	20%	TDK
L342	8228-001-35832	CU20	DC05	-	-	PHILIPS
L343	4330-030-38741	BDW3.5_6-4S2	BDW	-	-	PHILIPS
L344	3122-138-57081	AT4042_32A	Adj_Corr	-	-	PHILIPS
L345	B78108-S1824-J	820uH	B78108-S	-	5%	SIEMENS
L346	4330-030-38731	BDW3.5_4.5-4S2	BDW	-	-	PHILIPS
L347	4330-030-38731	BDW3.5_4.5-4S2	BDW	-	-	PHILIPS
OC200	9338-846-80127	CNX82A	CNX	-	-	PHILIPS
P201	MKS3736-1-0-606	MKS3730_6p	MKS3730	-	-	STOCKO

REF.	PART_NO	COMPONENT	SERIES	RATING	TOL.	VENDOR
P204	MKS3744-1-0-1414	MKS3730_14p	MKS3730	-	-	STOCKO
P205	210-535	VGA_BUS_15p_sqr	DCONN	-	-	FARNELL
P206	MKS3733-1-0-303	MKS3730_3p	MKS3730	-	-	STOCKO
P207	MKS3737-1-0-707	MKS3730_7p	MKS3730	-	-	STOCKO
P208	MKS3733-1-0-303	MKS3730_3p	MKS3730	-	-	STOCKO
P209	MKS3734-1-0-404	MKS3730_4p	MKS3730	-	-	STOCKO
P210	2422-015-12986	FASTON_WIRECONTACT	-	-	-	*
P211	2422-015-12986	FASTON_WIRECONTACT	-	-	-	*
P212	MKS3733-1-0-303	MKS3730_3p	MKS3730	-	-	STOCKO
P213	MKS3733-1-0-303	MKS3730_3p	MKS3730	-	-	STOCKO
P214	PCB-EXP-GEOM	Mains_inlet	-	-	-	*
P215	MKS3733-1-0-303	MKS3730_3p	MKS3730	-	-	STOCKO
R189	2322-187-53101	100	SFR16S	-	5%	BC
R190	2322-187-53479	47	SFR16S	-	5%	BC
R191	2322-484-75223	22k	EMP10	-	10%	BC
R192	2322-193-14519	51	PR01	-	5%	BC
R193	2322-187-53479	47	SFR16S	-	5%	BC
R194	2322-187-53109	10	SFR16S	-	5%	BC
R195	2322-187-53109	10	SFR16S	-	5%	BC
R200	2322-187-53104	100k	SFR16S	-	5%	BC
R201	2322-187-53223	22k	SFR16S	-	5%	BC
R202	2322-187-53103	10k	SFR16S	-	5%	BC
R203	2322-187-53333	33k	SFR16S	-	5%	BC
R204	2322-187-53333	33k	SFR16S	-	5%	BC
R205	2322-187-53103	10k	SFR16S	-	5%	BC
R206	2322-241-13475	4.7M	VR25	-	5%	BC
R207	2322-241-13475	4.7M	VR25	-	5%	BC
R208	2322-187-53223	22k	SFR16S	-	5%	BC
R210	2322-594-XXXXX	14 to 550V	VDR	-	-	BC
R211	2322-187-53105	n.m.	SFR16S	-	5%	BC
R212	2322-156-21501	150	MRS25	-	1%	BC
R214	2322-193-14478	4.7	PR01	-	5%	BC
R215	2322-187-53109	10	SFR16S	-	5%	BC
R216	2322-187-53102	1k	SFR16S	-	5%	BC
R217	2322-187-53471	470	SFR16S	-	5%	BC
R218	2322-187-53333	33k	SFR16S	-	5%	BC
R219	2322-193-14337	PR01/0.33	PR01	-	5%	BC
R220	2322-193-14337	PR01/0.33	PR01	-	5%	BC
R221	2322-156-21501	150	MRS25	-	1%	BC
R222	2322-187-53274	270k	SFR16S	-	5%	BC
R224	2322-193-14339	33	PR01	-	5%	BC
R225	2322-187-53471	470	SFR16S	-	5%	BC
R226	2322-156-21544	154k	MRS25	-	1%	BC
R227	2322-187-53103	10k	SFR16S	-	5%	BC
R228	2322-187-53471	470	SFR16S	-	5%	BC
R229	2322-187-53153	15k	SFR16S	-	5%	BC
R230	2322-187-53102	1k	SFR16S	-	5%	BC
R231	2322-187-53103	10k	SFR16S	-	5%	BC
R232	2322-156-22102	2.1k	MRS25	-	1%	BC
R233	2322-187-53104	100k	SFR16S	-	5%	BC
R234	2322-187-53222	2.2k	SFR16S	-	5%	BC
R235	2322-187-53103	n.m.	SFR16S	-	5%	BC
R236	2322-187-53473	47k	SFR16S	-	5%	BC
R237	2322-662-96687	MONO_PTC_20_276_26K	PTC	-	5%	BC
R240	2322-187-53333	33k	SFR16S	-	5%	BC
R241	2322-187-53472	4.7k	SFR16S	-	5%	BC
R242	2322-187-53472	4.7k	SFR16S	-	5%	BC
R243	2322-187-53101	100	SFR16S	-	5%	BC
R244	2322-187-53101	100	SFR16S	-	5%	BC

REF.	PART_NO	COMPONENT	SERIES	RATING	TOL.	VENDOR
R245	2322-187-53103	10k	SFR16S	-	5%	BC
R246	2322-187-53101	100	SFR16S	-	5%	BC
R247	2322-187-53101	100	SFR16S	-	5%	BC
R248	2322-187-53103	10k	SFR16S	-	5%	BC
R249	2322-187-53101	100	SFR16S	-	5%	BC
R250	2322-205-33108	1	NFR25	-	5%	BC
R251	2322-205-33108	1	NFR25	-	5%	BC
R252	2322-187-53101	100	SFR16S	-	5%	BC
R253	2322-187-53101	100	SFR16S	-	5%	BC
R254	2322-187-53101	100	SFR16S	-	5%	BC
R255	2322-187-53101	100	SFR16S	-	5%	BC
R256	2322-187-53101	100	SFR16S	-	5%	BC
R258	2322-187-53472	4.7k	SFR16S	-	5%	BC
R259	2322-187-53101	100	SFR16S	-	5%	BC
R260	2322-187-53472	4.7k	SFR16S	-	5%	BC
R261	2322-187-53101	100	SFR16S	-	5%	BC
R262	2322-187-53101	100	SFR16S	-	5%	BC
R263	2322-187-53472	4.7k	SFR16S	-	5%	BC
R264	2322-187-53472	4.7k	SFR16S	-	5%	BC
R265	2322-187-53101	100	SFR16S	-	5%	BC
R266	2322-186-76101	100	SFR25H	-	5%	BC
R267	2322-187-53472	4.7k	SFR16S	-	5%	BC
R268	2322-187-53101	100	SFR16S	-	5%	BC
R269	2322-187-53101	100	SFR16S	-	5%	BC
R270	2322-187-53101	100	SFR16S	-	5%	BC
R271	2322-187-53105	1M	SFR16S	-	5%	BC
R272	2322-187-53392	3.9k	SFR16S	-	5%	BC
R274	2322-187-53104	100k	SFR16S	-	5%	BC
R276	2322-187-53563	56k	SFR16S	-	5%	BC
R277	2322-187-53222	2.2k	SFR16S	-	5%	BC
R280	2322-187-53101	100	SFR16S	-	5%	BC
R281	2322-187-53101	100	SFR16S	-	5%	BC
R282	2322-187-53334	330k	SFR16S	-	5%	BC
R283	2322-187-53103	10k	SFR16S	-	5%	BC
R284	2322-187-53152	1.5k	SFR16S	-	5%	BC
R285	2322-187-53432	4.3k	SFR16S	-	5%	BC
R286	2322-187-53183	18k	SFR16S	-	5%	BC
R288	2322-187-53101	100	SFR16S	-	5%	BC
R289	2322-187-53683	68k	SFR16S	-	5%	BC
R291	2322-187-53182	1.8k	SFR16S	-	5%	BC
R292	2322-187-53273	27k	SFR16S	-	5%	BC
R293	2322-187-53103	10k	SFR16S	-	5%	BC
R295	2322-156-22742	2.74k	MRS25	-	1%	BC
R296	2322-156-21212	1.21k	MRS25	-	1%	BC
R298	2322-187-53332	3.3k	SFR16S	-	5%	BC
R299	2322-187-53XXX	XR_SFR16S	SFR16S	-	5%	BC
R300	2322-187-53683	68k	SFR16S	-	5%	BC
R301	2322-187-53XXX	XR_SFR16S	SFR16S	-	5%	BC
R302	2322-205-33478	4.7	NFR25	-	5%	BC
R303	2322-187-53223	22k	SFR16S	-	5%	BC
R304	2322-187-53101	100	SFR16S	-	5%	BC
R305	2322-187-53101	100	SFR16S	-	5%	BC
R306	2322-187-53101	100	SFR16S	-	5%	BC
R307	2322-187-53101	100	SFR16S	-	5%	BC
R308	2322-187-53101	100	SFR16S	-	5%	BC
R309	2322-187-53101	100	SFR16S	-	5%	BC
R310	2322-187-53101	100	SFR16S	-	5%	BC
R311	2322-187-53184	180k	SFR16S	-	5%	BC
R312	2322-187-53103	10k	SFR16S	-	5%	BC

REF.	PART_NO	COMPONENT	SERIES	RATING	TOL.	VENDOR
R313	2322-186-76475	4.7M	SFR25H	-	5%	BC
R315	2322-187-53333	33k	SFR16S	-	5%	BC
R316	2322-187-53101	100	SFR16S	-	5%	BC
R317	2322-186-76103	10k	SFR25H	-	5%	BC
R318	2322-187-53104	100k	SFR16S	-	5%	BC
R319	2322-187-53101	100	SFR16S	-	5%	BC
R320	2322-187-53472	4.7k	SFR16S	-	5%	BC
R321	2322-187-53121	120	SFR16S	-	5%	BC
R322	2322-187-53101	100	SFR16S	-	5%	BC
R323	2322-187-53101	100	SFR16S	-	5%	BC
R324	2322-187-53221	220	SFR16S	-	5%	BC
R325	2322-187-53568	5.6	SFR16S	-	5%	BC
R326	2322-187-53182	1.8k	SFR16S	-	5%	BC
R327	2322-187-53108	1	SFR16S	-	5%	BC
R328	2322-187-53182	1.8k	SFR16S	-	5%	BC
R329	2322-187-53108	1	SFR16S	-	5%	BC
R330	2322-187-53188	1.8	SFR16S	-	5%	BC
R340	2322-187-53103	10k	SFR16S	-	5%	BC
R341	2322-187-53822	8.2k	SFR16S	-	5%	BC
R342	2322-187-53101	100	SFR16S	-	5%	BC
R343	2322-187-53121	120	SFR16S	-	5%	BC
R344	2322-187-53563	56k	SFR16S	-	5%	BC
R345	2322-187-53102	1k	SFR16S	-	5%	BC
R346	2322-194-14471	470	PR02	-	5%	BC
R347	2322-187-53333	33k	SFR16S	-	5%	BC
R348	2322-187-53104	100k	SFR16S	-	5%	BC
R349	2322-187-53102	1k	SFR16S	-	5%	BC
R350	2322-187-53101	100	SFR16S	-	5%	BC
R351	2322-187-53154	150k	SFR16S	-	5%	BC
R352	2322-186-76102	1k	SFR25H	-	5%	BC
R353	2322-186-76102	1k	SFR25H	-	5%	BC
R354	2322-186-76681	680	SFR25H	-	5%	BC
R355	2322-186-76752	7.5k	SFR25H	-	5%	BC
R356	2322-187-53151	150	SFR16S	-	5%	BC
R357	2322-187-53479	47	SFR16S	-	5%	BC
R358	2322-187-53154	150k	SFR16S	-	5%	BC
R359	2322-187-53154	150k	SFR16S	-	5%	BC
R360	2322-187-53101	100	SFR16S	-	5%	BC
R361	2322-187-53154	150k	SFR16S	-	5%	BC
R362	2322-187-53103	10k	SFR16S	-	5%	BC
R363	2322-187-53103	10k	SFR16S	-	5%	BC
R364	2322-187-53103	10k	SFR16S	-	5%	BC
R365	2322-187-53689	68	SFR16S	-	5%	BC
R366	2322-187-53109	10	SFR16S	-	5%	BC
R367	2322-187-53472	4.7k	SFR16S	-	5%	BC
R368	2322-187-53472	4.7k	SFR16S	-	5%	BC
R369	2322-187-53472	4.7k	SFR16S	-	5%	BC
R371	2322-187-53102	1k	SFR16S	-	5%	BC
R372	2322-187-53188	1.8	SFR16S	-	5%	BC
R373	2322-187-53333	33k	SFR16S	-	5%	BC
R374	2322-187-53333	33k	SFR16S	-	5%	BC
R375	2322-187-53101	100	SFR16S	-	5%	BC
R376	2322-187-53153	15k	SFR16S	-	5%	BC
R377	2322-187-53471	470	SFR16S	-	5%	BC
R378	2322-187-53222	2.2k	SFR16S	-	5%	BC
R379	2322-187-53203	20k	SFR16S	-	5%	BC
R380	2322-187-53103	10k	SFR16S	-	5%	BC
R381	2322-187-53103	10k	SFR16S	-	5%	BC
R382	2322-187-53103	10k	SFR16S	-	5%	BC

REF.	PART_NO	COMPONENT	SERIES	RATING	TOL.	VENDOR
R383	2322-187-53101	100	SFR16S	-	5%	BC
R384	2322-187-53182	1.8k	SFR16S	-	5%	BC
R385	2322-187-53151	150	SFR16S	-	5%	BC
R386	2322-187-53101	100	SFR16S	-	5%	BC
R387	2322-187-53561	560	SFR16S	-	5%	BC
R388	2322-194-14109	10	PR02	-	5%	BC
R389	AB-EB1025	1k	EBx	-	5%	A-BRADLEY
R390	2322-187-53479	47	SFR16S	-	5%	BC
R392	2322-187-53104	100k	SFR16S	-	5%	BC
R393	2322-187-53363	36k	SFR16S	-	5%	BC
R394	2322-187-53479	47	SFR16S	-	5%	BC
R395	2322-187-53392	3.9k	SFR16S	-	5%	BC
R396	2322-187-53182	1.8k	SFR16S	-	5%	BC
R397	2322-187-53182	1.8k	SFR16S	-	5%	BC
RL200	625-589	RTE24 12Vdc 2x ch	RTE24	-	-	Farnell
T200	8228-001-3565C	CE423V	Switch_Mode	-	-	PHILIPS
T340	3128-138-35672	CU15/50	Line_driver	-	-	PHILIPS
T341	3138-138-31951	AT2097_32B	Line_Output	-	-	PHILIPS
T342	8228-001-38041	CU15	Dyn_foc	-	-	PHILIPS
TR200	9331-976-10112	BC547	Gen_Purpose	-	-	PHILIPS
TR201	9331-976-10112	BC547	Gen_Purpose	-	-	PHILIPS
TR202	9331-976-10112	BC547	Gen_Purpose	-	-	PHILIPS
TR203	STP7NB80FP	STP7NB80FP	fets	-	-	ST
TR204	9331-976-10112	BC547	Gen_Purpose	-	-	PHILIPS
TR205	9332-055-40112	BC556	Gen_Purpose	-	-	PHILIPS
TR272	9331-976-10112	BC547	Gen_Purpose	-	-	PHILIPS
TR273	9332-026-20112	BC557B	Gen_Purpose	-	-	PHILIPS
TR274	9331-976-10112	BC547	Gen_Purpose	-	-	PHILIPS
TR285	9332-026-20112	BC557B	Gen_Purpose	-	-	PHILIPS
TR286	9332-026-20112	BC557B	Gen_Purpose	-	-	PHILIPS
TR288	9334-311-90116	MPSA92	High_Voltage	-	-	PHILIPS
TR289	9331-976-10112	BC547	Gen_Purpose	-	-	PHILIPS
TR340	PN-IRF9630	IRF9630	fets	-	-	IR
TR341	9331-976-10112	BC547	Gen_Purpose	-	-	PHILIPS
TR343	9331-976-10112	BC547	Gen_Purpose	-	-	PHILIPS
TR344	9332-026-20112	BC557B	Gen_Purpose	-	-	PHILIPS
TR345	9335-354-70116	MPSA43	High_Voltage	-	-	PHILIPS
TR346	9340-557-64127	PHP18NQ20T	fets	-	-	PHILIPS
TR347	9340-557-64127	PHP18NQ20T	fets	-	-	PHILIPS
TR348	9340-557-64127	PHP18NQ20T	fets	-	-	PHILIPS
TR349	9340-548-01127	BU4523AF	Pow_HV_Switch	-	-	PHILIPS
TR350	9331-976-10112	BC547	Gen_Purpose	-	-	PHILIPS
TR351	9331-976-10112	BC547	Gen_Purpose	-	-	PHILIPS
TR352	9331-976-10112	BC547	Gen_Purpose	-	-	PHILIPS
TR353	9332-026-20112	BC557B	Gen_Purpose	-	-	PHILIPS
TR354	9332-026-20112	BC557B	Gen_Purpose	-	-	PHILIPS
TR355	9332-219-40112	BC639	Gen_Purpose	-	-	PHILIPS
TR356	BD677	BD677	Pow_Low_Freq	-	-	ST
TR390	9331-976-10112	BC547	Gen_Purpose	-	-	PHILIPS
X240	9922-520-12MHZ	12MHZ	Crystal	-	-	PHILIPS
Z200	9331-177-60153	BZX79C	BZX79C	7V5	-	PHILIPS
Z201	TL431C	TL431C	Misc	-	-	TI
Z202	9331-178-10153	BZX79C	BZX79C	12V	-	PHILIPS
Z285	9334-146-80153	BZX79C	BZX79C	2V4	-	PHILIPS
Z286	9331-177-10153	BZX79C	BZX79C	4V7	-	PHILIPS
Z321	9331-179-50153	BZX79C	BZX79C	47V	-	PHILIPS
Z340	9331-178-10153	BZX79C	BZX79C	12V	-	PHILIPS

6.2 Video board

REF.	PART_NO	COMPONENT	SERIES	RATING	TOL.	VENDOR
C1	2222-044-90501	1uF	RSH 044	250V	20%	BC
C2	2222-370-75104	100nF	MKT 370	63V	10%	BC
C3	2222-044-63109	10uF	RSH 044	250V	20%	BC
C4	2222-370-85334	330nF	MKT 370	100V	10%	BC
C5	2222-629-09102	1nF	C629	63V	-20 +80%	BC
C6	2222-370-75104	100nF	MKT 370	63V	10%	BC
C7	2222-370-35103	10nF	MKT 370	250V	10%	BC
C8	2222-370-75104	100nF	MKT 370	63V	10%	BC
C9	2222-370-85104	100nF	MKT 370	100V	10%	BC
C10	2222-370-75334	330nF	MKT 370	63V	10%	BC
C11	2222-037-58339	33uF	RSM 037	63V	20%	BC
C12	2222-370-75104	100nF	MKT 370	63V	10%	BC
C13	2222-370-35103	10nF	MKT 370	250V	10%	BC
C14	2222-044-90501	1uF	RSH 044	250V	20%	BC
C15	2222-370-75104	100nF	MKT 370	63V	10%	BC
C16	2222-370-35103	10nF	MKT 370	250V	10%	BC
C17	DE0807102K	1nF	Hi_voltage	2000V	10%	muRata
C18	2222-044-63109	10uF	RSH 044	250V	20%	BC
C19	DE0807102K	1nF	Hi_voltage	2000V	10%	muRata
C20	2222-044-90501	1uF	RSH 044	250V	20%	BC
C21	2222-681-10101	100pF	C638-NP0	100V	2%	BC
C22	2222-681-10569	56pF	C638-NP0	100V	2%	BC
C24	2222-370-75104	100nF	MKT 370	63V	10%	BC
C30	2222-044-63109	10uF	RSH 044	250V	20%	BC
C35	2222-044-32479	47uF	RSH 044	200V	20%	BC
C36	2222-037-51109	10uF	RSM 037	50V	20%	BC
C37	2222-037-54101	100uF	RSM 037	10V	20%	BC
C38	2222-037-56479	47uF	RSM 037	25V	20%	BC
C39	2222-370-75104	100nF	MKT 370	63V	10%	BC
C41	2222-370-35223	22nF	MKT 370	250V	10%	BC
C42	2222-629-09223	22nF	C629	63V	-20+80%	BC
C45	2222-370-75224	220nF	MKT 370	63V	10%	BC
C50	2222-370-75104	100nF	MKT 370	63V	10%	BC
C52	2222-681-10479	47pF	C638-NP0	100V	2%	BC
C53	2222-681-10479	47pF	C638-NP0	100V	2%	BC
C54	2222-370-35104	100nF	MKT 370	250V	10%	BC
C55	2222-629-09223	22nF	C629	63V	-20+80%	BC
C58	2222-629-09102	1nF	C629	63V	-20+80%	BC
C60	2222-629-09102	1nF	C629	63V	-20+80%	BC
C62	2222-370-65102	1nF	MKT 370	400V	10%	BC
D1	9330-839-90153	1N4148	Gen_Purpose	75V	-	PHILIPS
D2	9331-892-10153	BAV21	Gen_Purpose	-	-	PHILIPS
D3	9331-892-10153	BAV21	Gen_Purpose	-	-	PHILIPS
D4	9331-892-10153	BAV21	Gen_Purpose	-	-	PHILIPS
D5	9331-892-10153	BAV21	Gen_Purpose	-	-	PHILIPS
D6	9331-892-10153	BAV21	Gen_Purpose	-	-	PHILIPS
D7	9331-892-10153	BAV21	Gen_Purpose	-	-	PHILIPS
D8	9330-839-90153	1N4148	Gen_Purpose	75V	-	PHILIPS
I1	CVT3280-2202	CVT3280_CRT	-	-	-	SMK
IC3	PN-LM7808CT	LM7808CT	Stab_Pos	-	-	NS
IC4	PN-MC141545P2	MC141545P2	OSD generator	-	-	MOTOROLA
IC6	9352-640-61112	TDA4887PS	Video preamp	-	-	PHILIPS
IC7	PN-LM2435T	LM2435T	Video_amp	-	-	NS
L6	TSL0709-100K1R9	10uH	TSL0709	-	10%	TDK
L7	LAL03NAR22M	220nH	LAL03NA	-	10%	TAIYO_YUDEN

REF.	PART_NO	COMPONENT	SERIES	RATING	TOL.	VENDOR
L8	LAL03NAR22M	220nH	LAL03NA	-	10%	TAIYO_YUDEN
L9	LAL03NAR22M	220nH	LAL03NA	-	10%	TAIYO_YUDEN
P2	4022-007-45420	SOLDER-PIN_large	-	-	-	PHILIPS
P3	4022-007-45420	SOLDER-PIN_large	-	-	-	PHILIPS
P4	4022-007-45420	SOLDER-PIN_large	-	-	-	PHILIPS
P5	4022-007-45420	SOLDER-PIN_large	-	-	-	PHILIPS
P101	MKS3744-1-0-1414	MKS3730_14p	MKS3730	-	-	STOCKO
P102	MKS3736-1-0-606	MKS3730_6p	MKS3730	-	-	STOCKO
R1	2322-187-53109	10	SFR16S	-	5%	BC
R2	2322-187-53105	1M	SFR16S	-	5%	BC
R3	ERC12GJ470C	47	ERC12	-	5%	MATSUSHITA
R4	2322-193-14223	22k	PR01	-	5%	BC
R5	2322-187-53479	47	SFR16S	-	5%	BC
R6	2322-187-53101	100	SFR16S	-	5%	BC
R7	2322-187-53108	1	SFR16S	-	5%	BC
R8	2322-187-53103	10k	SFR16S	-	5%	BC
R9	2322-187-53683	68k	SFR16S	-	5%	BC
R10	2322-187-53101	100	SFR16S	-	5%	BC
R11	2322-187-53101	100	SFR16S	-	5%	BC
R12	2322-187-53101	100	SFR16S	-	5%	BC
R13	2322-187-53109	10	SFR16S	-	5%	BC
R14	2322-187-53101	100	SFR16S	-	5%	BC
R15	2322-187-53109	10	SFR16S	-	5%	BC
R16	2322-187-53101	100	SFR16S	-	5%	BC
R17	2322-187-53181	180	SFR16S	-	5%	BC
R18	2322-187-53332	3.3k	SFR16S	-	5%	BC
R19	2322-187-53109	10	SFR16S	-	5%	BC
R20	2322-205-33338	3.3	NFR25	-	5%	BC
R21	2322-187-53339	33	SFR16S	-	5%	BC
R22	2322-187-53101	100	SFR16S	-	5%	BC
R23	2322-187-53109	10	SFR16S	-	5%	BC
R24	2322-187-53759	75	SFR16S	-	5%	BC
R25	2322-187-53339	33	SFR16S	-	5%	BC
R26	2322-187-53109	10	SFR16S	-	5%	BC
R27	2322-187-53479	47	SFR16S	-	5%	BC
R28	2322-187-53759	75	SFR16S	-	5%	BC
R29	2322-187-53101	100	SFR16S	-	5%	BC
R30	2322-187-53101	100	SFR16S	-	5%	BC
R31	2322-187-53105	1M	SFR16S	-	5%	BC
R32	ERC12GJ470C	47	ERC12	-	5%	MATSUSHITA
R33	2322-187-53103	10k	SFR16S	-	5%	BC
R35	2322-187-53339	33	SFR16S	-	5%	BC
R36	2322-187-53101	100	SFR16S	-	5%	BC
R37	2322-193-14223	22k	PR01	-	5%	BC
R38	2322-187-53101	100	SFR16S	-	5%	BC
R39	2322-187-53109	10	SFR16S	-	5%	BC
R40	2322-187-53759	75	SFR16S	-	5%	BC
R41	2322-187-53103	10k	SFR16S	-	5%	BC
R42	2322-187-53683	68k	SFR16S	-	5%	BC
R43	2322-187-53109	10	SFR16S	-	5%	BC
R44	2322-187-53101	100	SFR16S	-	5%	BC
R45	2322-187-53221	220	SFR16S	-	5%	BC
R47	ERC12GJ272C	2.7k	ERC12	-	5%	MATSUSHITA
R49	2322-187-53101	100	SFR16S	-	5%	BC
R50	2322-187-53101	100	SFR16S	-	5%	BC
R51	2322-187-53181	180	SFR16S	-	5%	BC
R52	2322-187-53332	3.3k	SFR16S	-	5%	BC
R54	2322-187-53105	1M	SFR16S	-	5%	BC
R55	ERC12GJ470C	47	ERC12	-	5%	MATSUSHITA

REF.	PART_NO	COMPONENT	SERIES	RATING	TOL.	VENDOR
R56	2322-193-14223	22k	PR01	-	5%	BC
R58	2322-187-53103	10k	SFR16S	-	5%	BC
R59	2322-187-53683	68k	SFR16S	-	5%	BC
R61	2322-187-53181	180	SFR16S	-	5%	BC
R62	2322-187-53332	3.3k	SFR16S	-	5%	BC
R63	2322-205-33108	1	NFR25	-	5%	BC
R64	2322-187-53109	10	SFR16S	-	5%	BC
R65	2322-205-33108	1	NFR25	-	5%	BC
R68	2322-187-53109	10	SFR16S	-	5%	BC
R69	2322-187-53101	100	SFR16S	-	5%	BC
R71	2322-187-53102	1k	SFR16S	-	5%	BC
R73	2322-187-53562	5.6k	SFR16S	-	5%	BC
R76	2322-187-53182	1.8k	SFR16S	-	5%	BC
R78	2322-187-53561	560	SFR16S	-	5%	BC
R79	2322-187-53101	100	SFR16S	-	5%	BC
R82	2322-187-53224	220k	SFR16S	-	5%	BC
R83	2322-187-53102	1k	SFR16S	-	5%	BC
R85	2322-187-53105	1M	SFR16S	-	5%	BC
R88	2322-187-53101	100	SFR16S	-	5%	BC
R92	2322-187-53103	10k	SFR16S	-	5%	BC
R93	2322-187-53103	10k	SFR16S	-	5%	BC
R95	2322-187-53101	100	SFR16S	-	5%	BC
R96	2322-187-53101	100	SFR16S	-	5%	BC
R98	2322-187-53101	100	SFR16S	-	5%	BC
R99	2322-187-53109	10	SFR16S	-	5%	BC
R103	2322-187-53479	47	SFR16S	-	5%	BC
R107	2322-187-53479	47	SFR16S	-	5%	BC
R110	2322-205-33101	100	NFR25	-	5%	BC
R112	2322-187-53479	47	SFR16S	-	5%	BC
R114	2322-187-53101	100	SFR16S	-	5%	BC
R115	ERC12GJ272C	2.7k	ERC12	-	5%	MATSUSHITA
R116	2322-194-14828	8.2	PR02	-	5%	BC
TR1	9331-976-10112	BC547	Gen_Purpose	-	-	PHILIPS
TR2	9335-354-70116	MPSA43	High_Voltage	-	-	PHILIPS
TR3	9331-976-10112	BC547	Gen_Purpose	-	-	PHILIPS
TR4	9335-354-70116	MPSA43	High_Voltage	-	-	PHILIPS
TR5	9331-976-10112	BC547	Gen_Purpose	-	-	PHILIPS
TR6	9335-354-70116	MPSA43	High_Voltage	-	-	PHILIPS
TR8	9331-677-30112	BF324	High_Freq	-	-	PHILIPS
TR9	9332-377-90112	BC547C	Gen_Purpose	-	-	PHILIPS
Z1	9331-177-40153	BZX79C	BZX79C	6V2	-	PHILIPS

NS: National Semiconductor

TI: Texas Instruments

IR: International Rectifier

BC: Beyschlag

ST: SGS-Thomson

7. MODIFICATIONS

Modifications on the main board PR39873:

#	Reference	Old Value	Modification
1.	R395	3.9 kΩ	Change value to 2.7kΩ
2.	C321	220 nF	Change value to 100 nF
3.	L343	Bead on wire	Replace by bridge wire
4.	C369	15 nF	Do not mount
5.	C366	3.3 nF	Do not mount
6.	R384	1.8 kΩ	Change value to 1.5 kΩ
7.	R379	20 kΩ	Change value to 24 kΩ
8.	C352	470 nF	Change value to 560 nF
9.	C350	82 nF	Change value to 150 nF
10.	C351	220 nF	Change value to 270 nF
11.			Place SFR16S resistor of 22 Ohm parallel to L346
12.			Place SFR16S resistor of 22 Ohm parallel to L347

Modifications on the video board PR70192:

#	Reference	Old Value	Modification
13.	C21	100 pF	Do not mount
14.	C22	56 pF	Do not mount
15.	R92	10 kOhm	Change value to 2.2 kOhm
16.	R33	10 kOhm	Change value to 3.3 kOhm

8. ALIGNMENT

8.1 Used equipment

Video generator	With VESA modes
DMM	Fluke PM2421
EHT meter	Brandenburg
Oscilloscope	Tektronix TDS420
Colour analyser	Philips PM5639
PC	Minimum '486' with I2C interface card
Software	I2C menu software version 3.50.xx for TDA4856 and TDA4887

8.2 Jumper settings

Make sure that the jumpers are in the positions as shown in Figure 8-1 PCB overview of jumper settings.

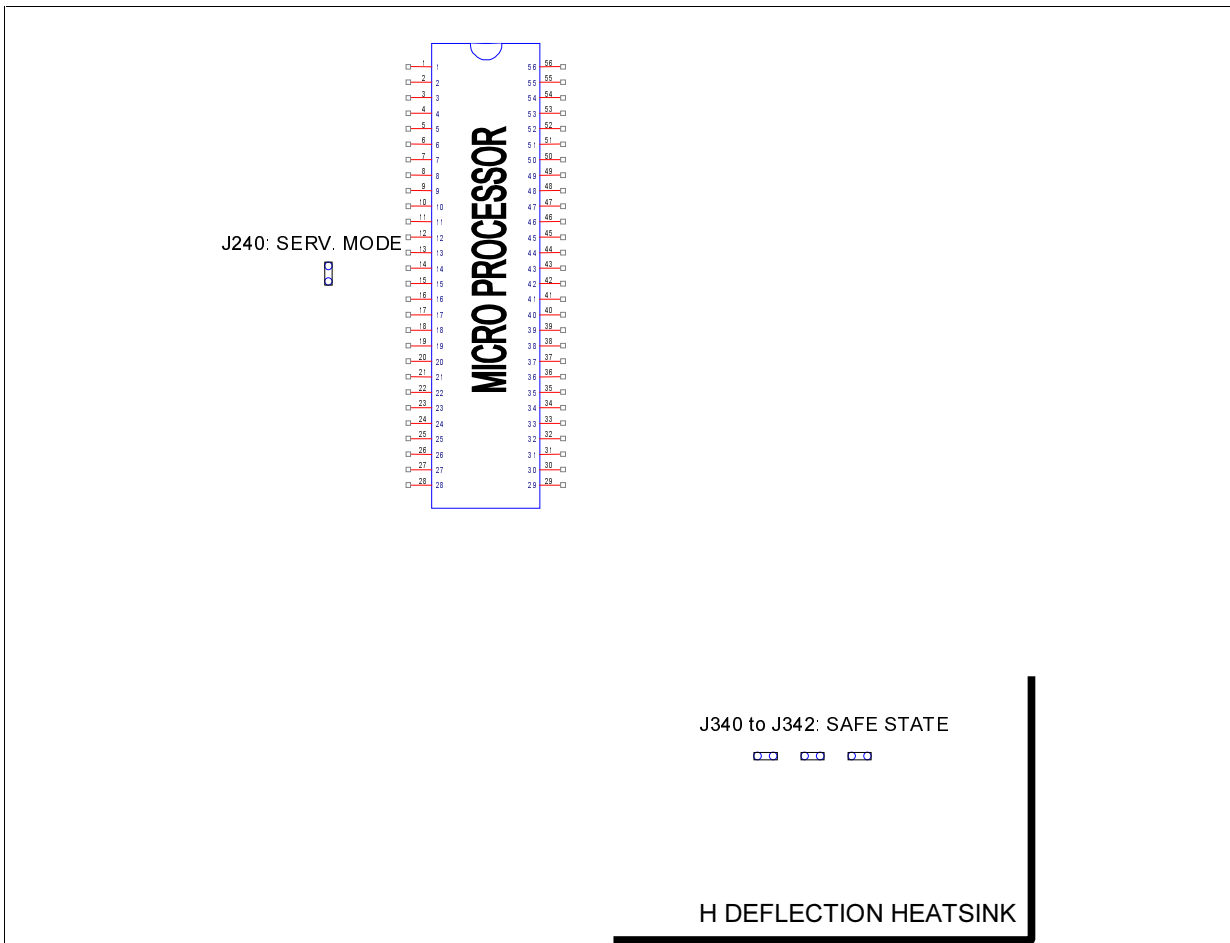

Figure 8-1 PCB overview of jumper settings

8.3 First time adjustment

1. Put in the jumpers on the main board according Figure 8-1 PCB overview of jumper settings.
2. Connect the video generator and apply a signal with 1024x768 pixels at 60Hz refresh rate (Fh=48kHz)
3. Choose SMPTE test pattern
4. Connect the EHT voltmeter between anode and aqua deck of the CRT
5. Load EEPROM file "ECO.epr" into EEPROM with I²C software and switch monitor off and on
6. If possible make use of a separate degaussing device to demagnetise the CRT
7. Connect the mains supply and switch the monitor on with the functional switch
8. Check that the monitor displays a picture after 8 seconds. If not refer to the debug section.
9. Adjust the EHT voltage to 26.0 kV (± 0.2 kV) with potentiometer R191
10. Display a crosshatch pattern
11. Set dynamic V_focus to max with I2C software. The dynamic focus adjustment is done after the colour adjustment.
12. Adjust the static focus with the focus potentiometer on the line output transformer. Set the static focus while looking at screen area shown in Figure 8-2 On screen checking area. The white circle is the area you should adjust for perfect focus.
13. Test a mode change. If the OSD menu displays the correct frequencies turn off monitor and set SAFE STATE off (jumpers J340 to J342).
14. Test the keypad

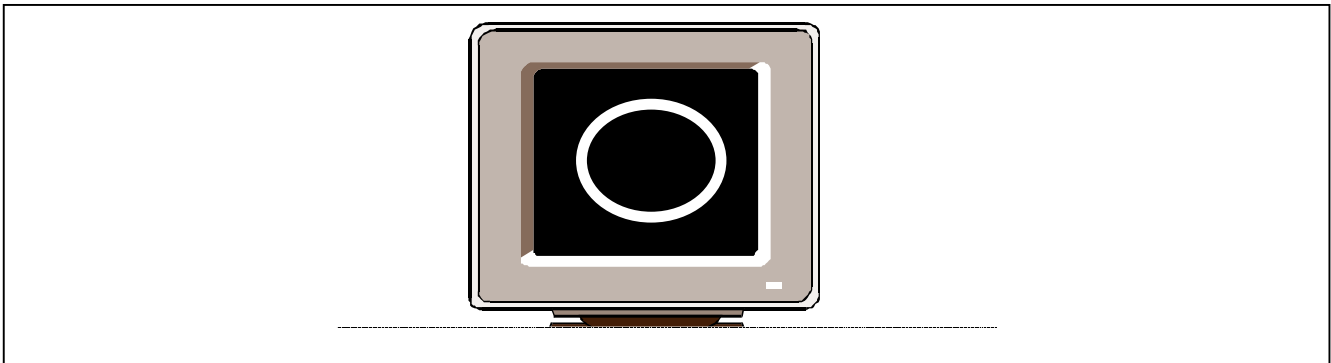

Figure 8-2 On screen checking area of static focus

8.4 Geometrical adjustment

Notes

- *The raster is the area scanned by the deflection and is visible at high setting of brightness.*
 - *The picture is the area with active video, e.g. a crosshatch pattern.*
1. Press the menu button once: check that the OSD shows the mode information and the user control menu is displayed
 2. Linearity adjustments

- 2.1 Set VSIZE=127 and VPOS=63
- 2.2 Adjust VOFFS and VGAIN for edge-to-edge phosphor area raster scanning.
- 2.3 Adjust VLIN and VLINBAL for equal height of all blocks of a crosshatch.
- 2.4 Adjust VPOS and VSIZE for correct vertical position and height of the picture.
- 2.5 Adjust HPOS and HSIZE for correct horizontal position and width of the picture.
- 2.6 Adjust trapezium (HTRAP) and parallelogram (HPARAL) until the middle sections of the vertical borders are vertical.
- 2.7 Adjust pincushion HPIN and pinbalance HPINBAL until the centre sections of the left and right vertical borders become straight.
- 2.8 Adjust the top HCORT and bottom HCORB corners until the whole vertical borders become straight.

8.5 Colour adjustment

(Please contact SLE for factory alignment. The second black level adjustment can be avoided by means of a compensation method in the alignment control software.)

1. Display SMPTE test pattern.
2. If video booster saturates adjust the “Reference voltage” in the I2C software. Default value is 0.75V.
3. Set brightness to 64.
4. Set contrast to 235.
5. Turn black levels (reference levels) to 48 in I2C software.
6. Turn vg2 to minimum with the screen potentiometer on the line output transformer (counter clockwise).
7. Display test pattern with a 1-nit square.
8. Turn up vg2 until the 1-nit square becomes visible.
9. Tune black levels Rb, Bb and Gb to 1 nit (± 0.1). Choose colour temperature 6500K on colour analyser and on I2C software.
10. Display test pattern with a 100-nit square.
11. Tune gain levels Rg, Bg and Gg to 100nit (± 5) with correct balance to colour temperature.
12. Go back to black level adjustment until the black and white levels are according specification.
13. Do the gain level adjustments also for colour temperatures 5500K and 9300K.
14. Save the settings

8.6 Focus adjustment

1. Display a focus pattern (e.g. random text).
2. Adjust static focus
3. Adjust the dynamic focus potentiometer on line output transformer for optimum sharpness on the centre and the edges of the screen.
4. Re-adjust static focus and repeat step 3 if necessary.

8.7 Adjusting other video modes

(Do not change other settings, as they are valid for all modes.)

1. Set video generator to new factory mode.
2. Adjust HPOS, HSIZE, VPOS and VSIZE.

8.8 Programming serial number

The serial number needs to be programmed in the EEPROM via I²C-software.

Go to menu "General I2C Test"

Fill in *Device address* = HAO

Sub address = 373

Value = xx (where xx is the serial number)

Press 'write' button.

The serial number becomes visible when the monitor is turned on with no VGA input signals.

9. DEBUGGING

PROBLEM	CHECK IF
No picture	<ul style="list-style-type: none"> • SMPS voltages +185V, +82V, +16V, +12V_stab, +10V, -10V, +5V_stab are present • +12V ($\pm 0.75V$) on pin 10 of the TDA4856 is present • +5V ($\pm 0.25V$) on pin 11, pin 32 of micro processor (IC240) is present • Supply voltage on video board 8V is present • Keypad is connected • Hsync is present on pin 13 and 14 of micro processor (IC240) • Vsync is present on pin 16 and 17 of micro processor (IC240) • H_unlock on R248 is a pulse between 0 and 1 V and not higher • Collector of TR289 is low • Grid1 voltage is approximately -0.3V • Grid2 voltage is between approximately 500 and 800V • BeamLim voltage > 4.5V on pin 8 of P101 (video board) • Heater current is 0.3A (2.5V voltage drop over R116 of video board) • EHT is 26kV • There is I2C communication during start-up (disconnect external I2C cable)
185 volt not present	<ul style="list-style-type: none"> • Voltage over C211 is approx. 1.4 x mains voltage • DPMS1 on R202 is LOW • L200 is not damaged • Fuse F200 is not blown • Output rectifier D208 is not blown • Horizontal deflection transistors TR340, TR349 are not broken • Supply voltage on pin 1 of SMPS controller (IC200) is about 16 V • Output drive signal pin 6 of SMPS controller (IC200) 13V pulse signal • SMPS switching device TR203 is not broken • Over-current protection level on pin 5 of IC200 is a sawtooth signal with peak value < 750mV
Auxiliary SMPS not present	<ul style="list-style-type: none"> • Output rectifiers D210, D211, D213, D216 are not broken • +12V voltage stabiliser IC201 is not broken • +5V voltage stabiliser IC202 is not broken
Distorted picture	<ul style="list-style-type: none"> • Alignment is ok • Linearity correction switches are not in safe state (jumpers J340 to J342) • Linearity balance corrector has the right value • Vertical flyback signal Tfb=300us ($\pm 50us$); Vpeak = 47V ($\pm 3V$) • All supply voltages do not have excess ripple voltages: 185V (<0.200Vpp); 10V (<1Vpp); -10V (<1Vpp) • Your video mode may not be an interlaced mode

PROBLEM	CHECK IF
No horizontal deflection	<ul style="list-style-type: none"> • TDA4856 is initialised • HDRV (pin 8) and BDRV (pin 6) signals of TDA4856 (both pulse signals) are present • Horizontal deflection transistors T340 and T349 are not broken • Base drive voltage of T349 is present • Gate drive voltage of T340 is present • Hunlock signal is a pulse between 0 and 1 V, not higher
No vertical deflection	<ul style="list-style-type: none"> • TDA4856 is initialised • Vertical drive signals on pin 6 and 7 of TDA4863J (1Vpp) are present • Flyback supply voltage of 47V on pin 2 of TDA4863J is present • Vertical deflection output stage is not broken
No Vgl	<ul style="list-style-type: none"> • Protection signals "Vdefl_pl" pulsed high, "H_unlock" low
No dynamic focus	<ul style="list-style-type: none"> • DAF input on line output transformer pin 12 is a Horizontal & Vertical parabola • Focus signal on pin 32 of TDA4856 is present • Dynamic focus transistor TR345 is OK
No rotation control	<ul style="list-style-type: none"> • resistors R194, R195 are not broken • DC signal Rotation is between 0 and 5.0 volt
No OSD	<ul style="list-style-type: none"> • keypad signal on pin 3 of P87C380 is changed while operating keypad • I2C signals on connector P7 (video board) are present • Hflyback is present on pin 5 of MTV018 (IC4 video board) • Vsync_m is present on pin 10 of MTV018 (IC4 video board) • OSD Menu is not out of visible area (position) • OSD Contrast is high • OSD signals (RGB & enable) are present on video preamp

10. OSCILLOGRAMS

Measurements were done at two video modes:

640x480 at 60 Hz refresh rate, horizontal frequency is 31 kHz,

1024x768 at 85 Hz refresh rate, horizontal frequency is 68 kHz.

Both modes are depicted in one oscillogram, except for Figure 10-6 and Figure 10-9.

10.1 Horizontal Deflection

Line output transistor = TR349

Line driver transistor = TR355

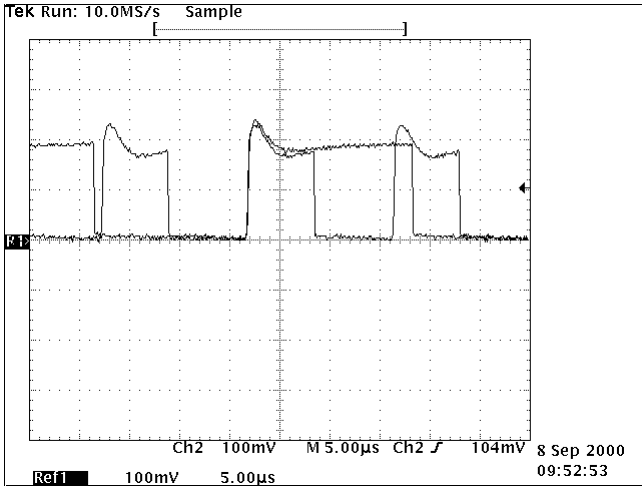

Figure 10-1: Collector voltage of TR355

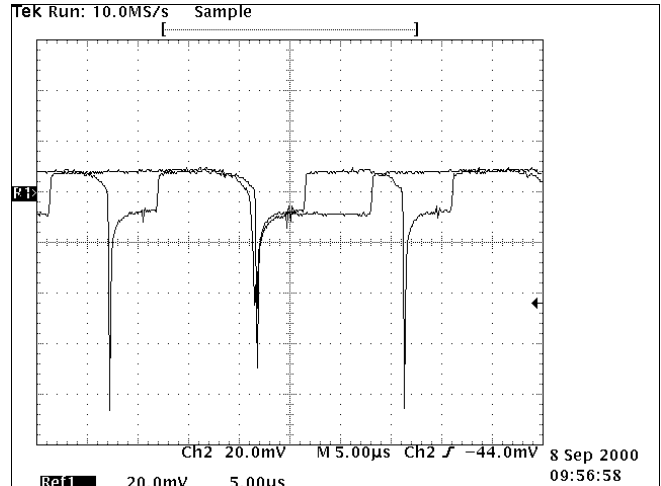

Figure 10-2: Base voltage of TR349

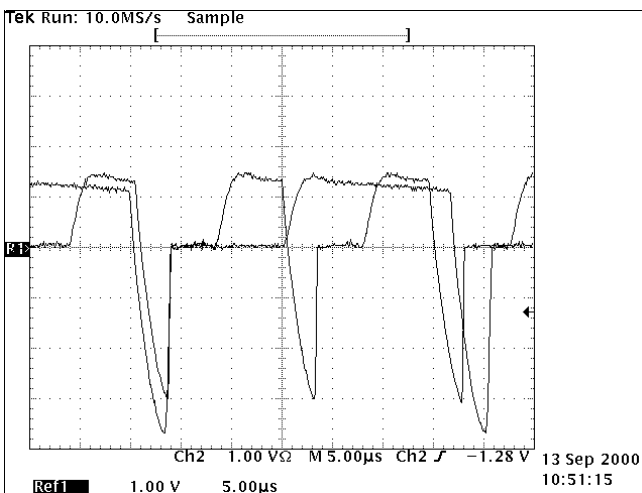

Figure 10-3: Base current of TR349

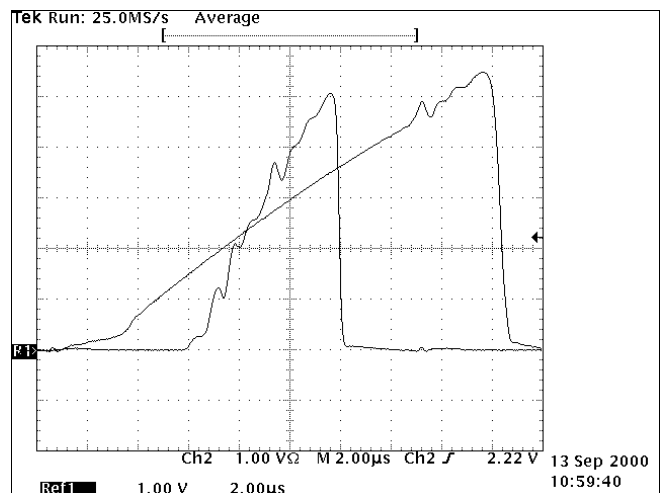

Figure 10-4: Collector current of TR349

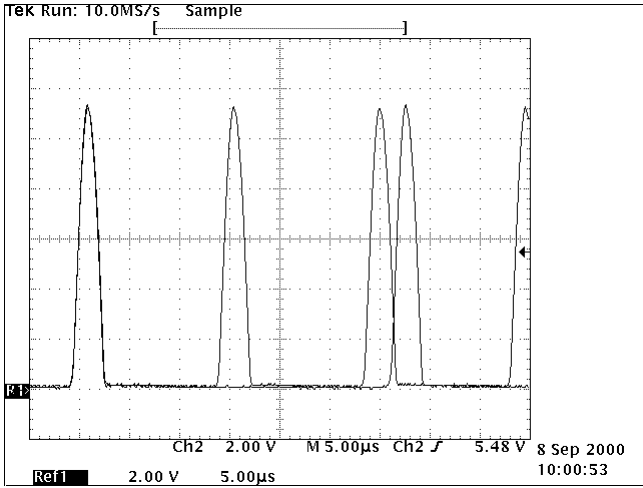

Figure 10-5: Collector voltage of TR349 (=flyback voltage)

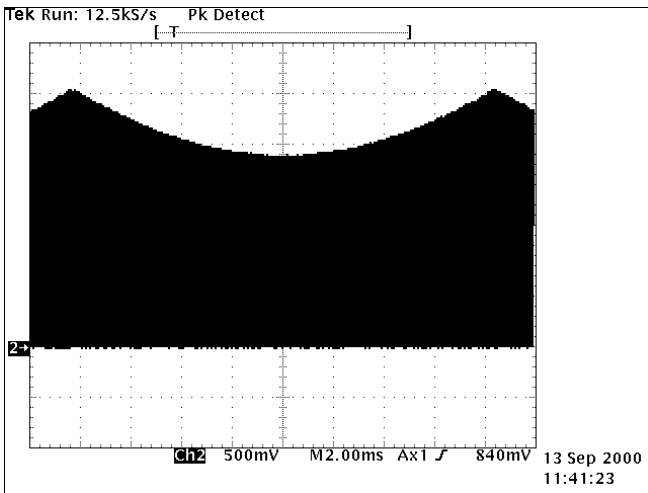
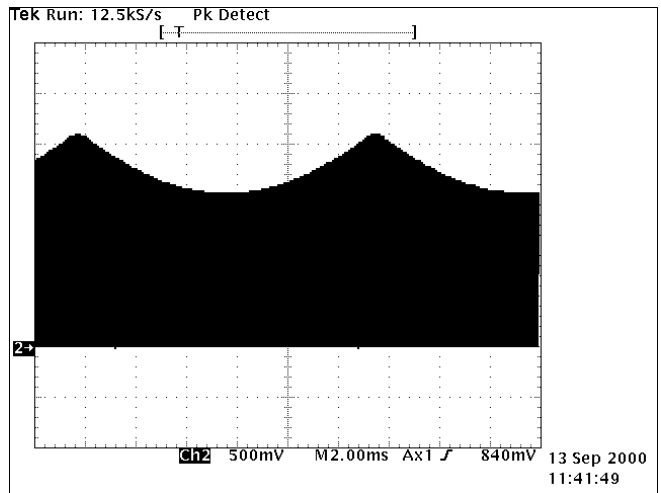

Figure 10-6: EW modulator diode voltage



10.2 Vertical deflection

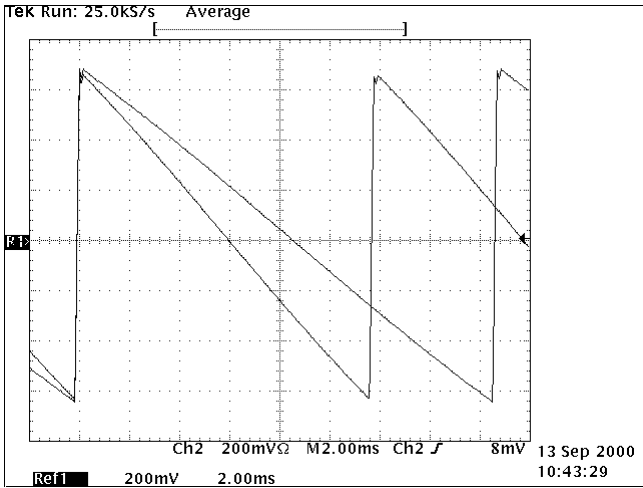

Figure 10-7: Vertical deflection current

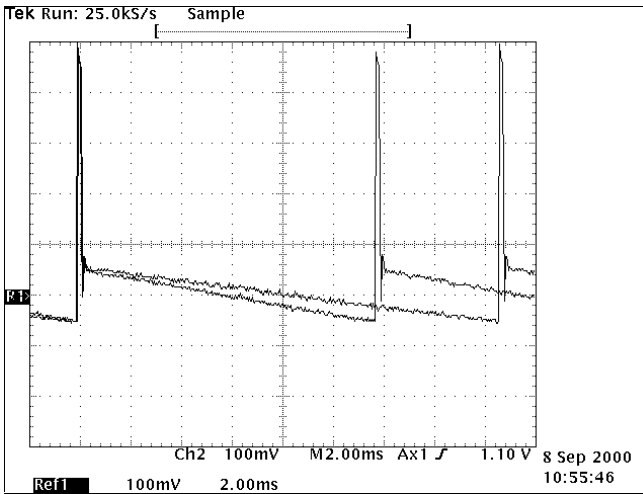

Figure 10-8: Vertical deflection output voltage

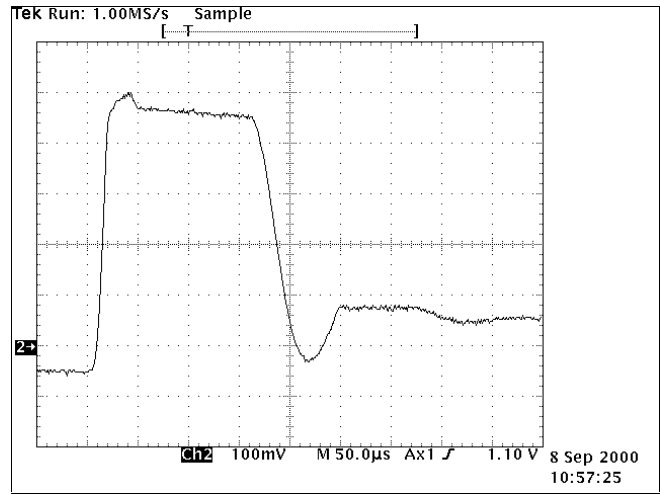

Figure 10-9: Vertical flyback voltage

10.3 Dynamic focus

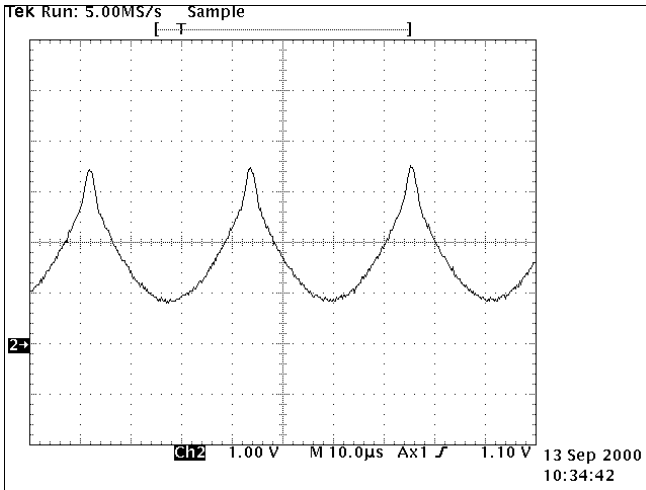

Figure 10-10: Horizontal dynamic focus at 31 kHz

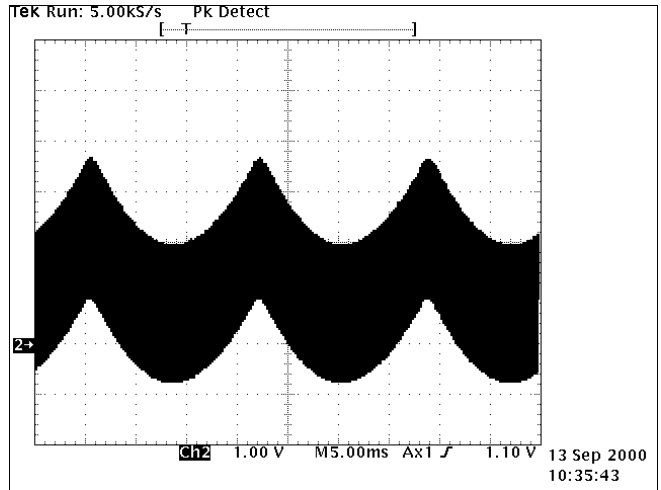

Figure 10-11: Vertical (+ horizontal) dynamic focus at 60 Hz

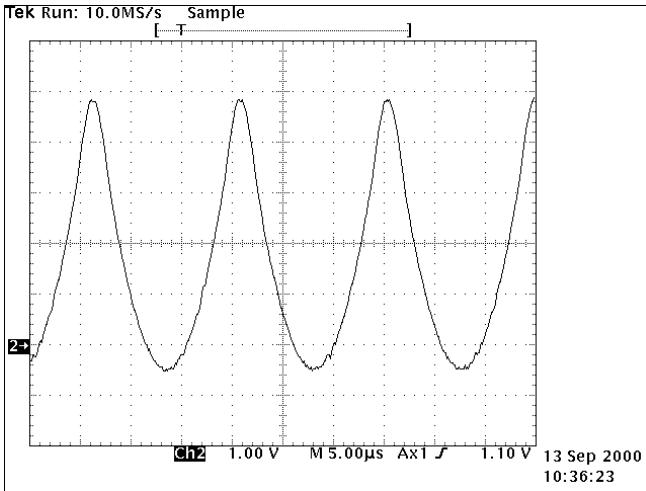

Figure 10-12: Horizontal dynamic focus at 68 kHz

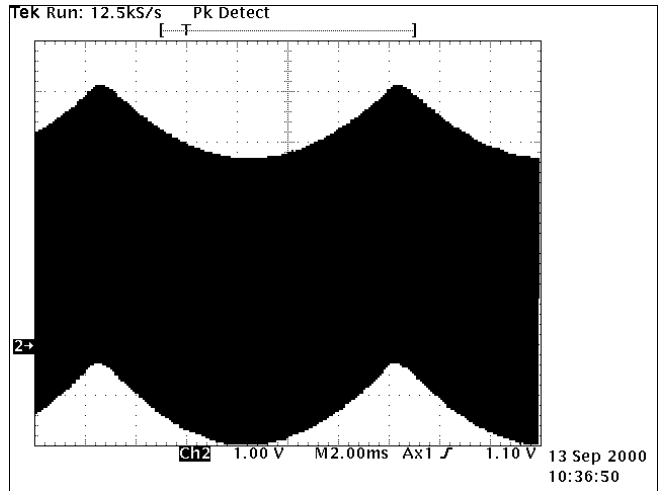

Figure 10-13: Vertical (+ horizontal) dynamic focus at 85 Hz

11. DESIGN & EMC CONSIDERATIONS

11.1 EMC

The ECO Monitor has passed the EN55022 as mentioned in **AN00038** *EMC of Monitors*.

- The heatsinks are mounted on the PCB with special mounting studs. Some of these studs are connected to the ground plane of the circuit. This grounding provides also EMI shielding.
- The ferrite core provides HF decoupling in the video cable.
- The aquadag is directly connected to the groundplane of the video board by means of a thick wire. In this way the HF video currents are kept local.
- An extra grounding wire from the LOT to the video board groundplane provides a low ohmic path to the EHT source, which is also crucial for flashes.

11.2 TCO'99

The ECO is not prepared for TCO'99.

Alternating electrical field:

30cm in front of screen:	The RMS value of the alternating electrical field 30cm in front of screen is \leq ??? V/m.
50cm around monitor:	Without extra effort the left side of monitor does not comply with TCO requirements. All other sides comply with TCO. No extra effort was taken in order to keep good serviceability of the deflection parts.

Advice for cancelling alternating electrical field around the monitor:

- place the horizontal output transistor and the flyback diode (parts that carry the flyback pulse) of the deflection circuit behind the grounded heatsink;
- keep all tracks that carry the flyback voltage short in order to lower capacity to the environment;

No magnetic field investigations were done.

11.3 Lay-out hints

11.3.1 Ground track

The common ground track should be kept as clean as possible. This means that only DC currents should be flowing through this track indicating that the AC currents are short-circuited at their source! Therefore you will find resistor capacitor filters at every stage.

For more information see the application note **AN00038** *EMC of Monitors*.

11.3.2 Vertical deflection

Keep vertical drive signals of the TDA4856 close to each other at all places to avoid magnetic coupling in the loop and to avoid differential stray signals.

Apply a separate ground track from the vertical output stage to the SMPS and don't let other circuits make use of this ground track.

11.3.3 Horizontal deflection output stage

Keep flyback capacitor and diode of the horizontal deflection stage located close together to minimise the forward recovery ringing of the flyback diode. To damp the ringing even further a bead-on-wire can be placed in series with the flyback capacitors.

Keep current loops that carry the switched horizontal deflection current as small as possible.

11.3.4 Video

Make the ground return path as short, but as wide as possible (a ground plane underneath the picture tube socket is recommended because of the low impedance).

Advantages ground plane:

- Current loops are created if only ground tracks (instead of a ground plane) are used and this can easily cause oscillations;
- Shielding against EMI.

Disadvantage ground plane:

- The ground plane creates parasitic capacitance to the large signal paths. So be aware when you apply a ground plane close to the copper tracks carrying video signals with large amplitude. Too much parasitic capacitance will reduce the video bandwidth.

12. EMBEDDED SOFTWARE

The embedded software takes care for the following:

- Automatic adaptation to a new video mode, by checking the horizontal and vertical sync frequencies and polarities;
- Storage of 10 factory predefined and 10 free programmable video modes;
- 3 key and OSD menu based user interface;
- External monitor control by means of the DDC bus interface;

12.1 Video mode adaptation

Automatic mode adaptation to a new incoming video mode:

- Horizontal sync frequencies from 30 kHz up to 70 kHz;
- Vertical sync frequencies from 50 Hz up to 160 Hz;
- Horizontal and vertical sync polarity detection;
- Automatic sync input selection between:
 - Separate H-/V-sync signals on the H-/V-sync inputs;
 - Composite H-/V-sync signals on the H-sync input;
- Full VESA DPMS switching, supporting the modes: on, standby, suspend and off;
- Storage of:
 - 10 factory predefined video modes. The frequencies must be pre-programmed into the NVM. (Horizontal, vertical frequency and polarities); The predefined video modes can however be re-adjusted by the user, but can always be recovered by pushing “recall factory mode”.
 - 10 free programmable video modes, the user list. In case a video mode is detected which is not in the list of pre-programmed video modes, it will be placed in the user list. When a new video mode is detected and the list is full, the software will overwrite the oldest entry in the list.
- The following controls are stored for each video mode:
 - Horizontal position and size;
 - Vertical position and size;
 - Horizontal and vertical moire;
 - Horizontal pincushion and pincushion-balance;
 - Horizontal top corner and bottom corner correction;
 - Brightness;
 - Contrast;

12.2 OSD status messages

The following OSD status messages are displayed:

- **“No Sync Input”**: monitor is switched on with no valid sync signals. This message is shown together with the monitor status:
 - SW compilation date and version number;
 - Monitors serial number;
- **“No VGA Cable”**: monitor is switched on with no VGA cable connected. This message is shown together with the monitors status:
 - SW compilation date and version number;
 - Monitors serial number;
- **“Sync Out Of Range”**: the current video mode is not valid, the horizontal and/or vertical frequencies are/is not valid;

While displaying a status message the monitor is set to a free running frequency of 38 kHz and 72 Hz.

12.3 User interface and OSD menu control

The user interface consists of 3 menu selection and adjust keys, see the table below.

Key:	Menu	Select / Adjust	
		Down	Up
Menu status:			
OSD menu is not active	Activate OSD menu	Contrast down	Contrast up
OSD menu is active	<ul style="list-style-type: none"> • Select next menu; • Activate current menu item, e.g. degauss; • Toggle current menu item between the select and adjust mode; 	In select mode :	
		Select previous menu item	Select next menu item
		In adjust mode :	
		Adjust selected menu item up	Adjust selected menu item down

A jumper (J 240) to select between “user preferred” and “service preferred” mode:

- User mode:
 - a limited set of controls to adjust;
 - automatic regular (every 5 seconds) update of I2C-bus registers;
 - OSD menu timeout of 10 seconds;
- Service mode:
 - an extensive set of controls to adjust;
 - regular update of I2C-bus registers is disabled (this allows the usage of an external PC with windows based software to control the I2C-bus IC’s in the monitor);

- no OSD menu timeout;

The jumper preferred selected mode can be toggled by pressing the keys “menu” and “select/adjust up” simultaneously during switching on the set. This can be useful during e.g. road-shows, by keeping the set in “user” mode, but to demonstrate a specific control, the set can be temporary set to “service”. After finishing the demonstration, the set has to be switched-off and on again to “user” mode, without having to open the cabinet.

12.3.1 OSD menu layout

The OSD menu consists of 5 lines, displaying the following information:

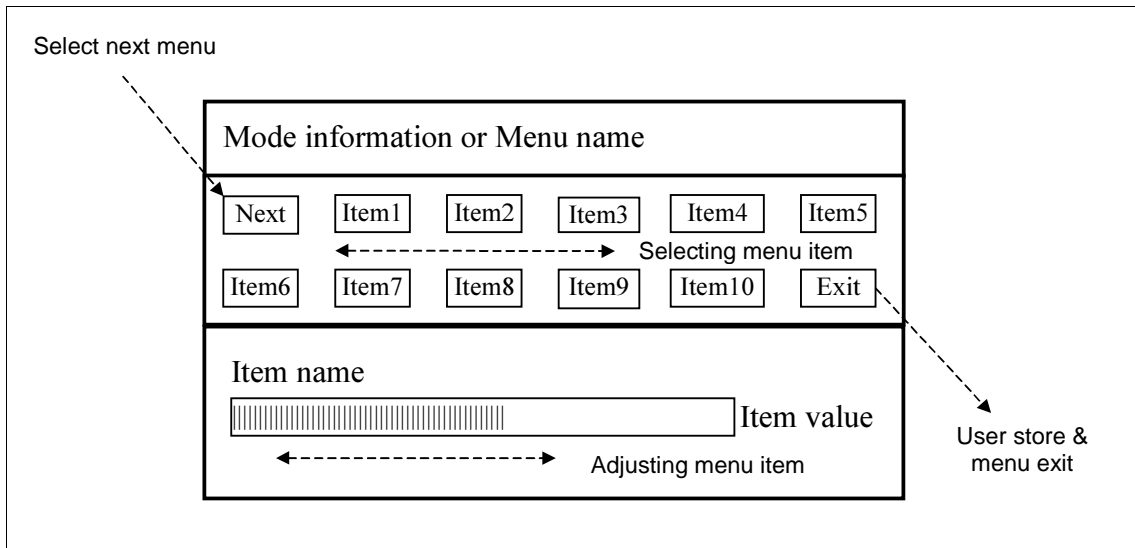

Figure 14 OSD menu structure

OSD user menu

Item nr:	Menu item:
Main menu:	
Next	Select Colour menu
1	Brightness
2	Contrast
3	H position
4	H size
5	V position
6	V size
7	H pincushion
8	H top corner
9	H bottom corner
10	H pincushion balance
Exit	User store & exit

Item nr:	Menu item:
Colour menu:	
Next	Select Miscellaneous menu
1	Colour temperature (CT)
2	Red gain (only for CT user settings)
3	Green gain (only for CT user settings)
4	Blue gain (only for CT user settings)
5..10	-
Exit	User store & exit
Miscellaneous menu:	
Next	Select Main menu
1	Degauss on
2	H moire
3	V moire
4	Tilt
5	-
6	OSD contrast (minimum value = 4)
7	OSD H position
8	OSD V position
9	User recall
10	Factory recall
Exit	User store & exit

OSD service menu

Item nr:	Menu item:
Main menu:	
Next	Select Colour menu
1	Brightness
2	Contrast
3	H position
4	H size
5	V position
6	V size
7	H pincushion
8	H top corner
9	H bottom corner
10	H pincushion balance
Exit	User store & exit
Colour menu:	
Next	Select Miscellaneous menu
1	Colour temperature (CT)

Item nr:	Menu item:
2	Red gain
3	Green gain
4	Blue gain
5	-
6	Black level for AC coupling (Note: only for the TDA4887)
7	Depth of pedestal blanking (Note: only for the TDA4887)
8	Red bias
9	Green bias
10	Blue bias
Exit	User store & exit
Miscellaneous menu:	
Next	Select Horizontal menu
1	Degauss on
2	H moire
3	V moire
4	Tilt
5	V focus
6	OSD contrast (minimal value = 4)
7	OSD H position
8	OSD V position
9	User recall
10	Factory recall
Exit	User store & exit
Horizontal menu:	
Next	Select Vertical menu
1	H position
2	H size
3	H trapezium
4	H parallelogram
5, 6	-
7	H pincushion
8	H top corner
9	H bottom corner
10	H pincushion balance
Exit	User store & exit
Vertical menu:	
Next	Select Main menu
1	V position
2	V size
3	V linearity
4	V linearity balance
5, 6	-

Item nr:	Menu item:
7	V offset
8	V gain
9, 10	-
Exit	User store & exit

12.3.2 Menu item descriptions

The sections below describe some OSD menu items in more detail.

User store and exit

The modified controls are stored into the NVM and the OSD menu is cancelled. This function will also be executed:

- automatically in user mode after the OSD menu timeout;
- when pressing the menu key on a main menu item which is intended to be adjusted, e.g. pressing the menu key while brightness is selected or adjusted;

User recall

A user recall fetches, (and updates the IC's), the previous stored user settings from the NVM.

Factory recall

A factory recall fetches, (and updates the IC's), the settings from the NVM which are stored during pre-programming the NVM. They are never changeable by the user.

Colour Temperature (CT) selection

A selection can be made out of 4 settings:

- Fixed settings: 5500K, 6500K and 9300K;
- User modifiable setting;

It is advisable to store & exit the menu in during adjusting the R-/G-/B-gain and/or R-/G-/B-bias for each CT setting. This due to the fact that only one set of these settings, (R-/G-/B-gain, R-/G-/B-bias), is stored into the micro-controller, and selection of an other CT setting will override the just modified settings.

12.4 External interface control

External monitor control is possible by means of the DDC interface.

12.4.1 DDC

- Full support of level DDC1;
- Support of level DDC2 including DDC2B and DDC2Bi;
- EDID version-1 support and prepared for EDID version-2;
(Note: EDID version-2 is disabled in the current software version)

- Controlling monitor functions according the VESA monitor command set, (see 12.5), in DDC2Bi mode only. (The ACCESS.bus commands must be used, see the table below. Note: see the ACCESS.bus specification for more information)

Supported ACCESS.bus Interface Op-Codes:		
Function:	Op-code (hex)	Description:
Identification Request	F1	Request the monitor to send a complete identification replay.
Identification Reply	E1	Monitors reply to an Identification Request
Capabilities Report	F3	Request the monitor to reply with a Capabilities Reply
Capabilities Reply	E3	Monitors reply to a Capabilities Report
Enable Application Report	F5	Instructs the monitor to start (enable) or to stop (disable) sending application reports
Application Test	B1	Request the monitor to reply with the self-test results
Application Test Reply	A1	Monitors reply to a Application Test
Supported ACCESS.bus Monitor Op-Codes:		
Request:	Op-code (hex)	Description:
GET VCP FEATURE	01	Command instructs the monitor to send information about the selected control feature back to the host in a replay message. The VCP op-code informs the monitor which feature to return
VCP FEATURE REPLY	02	Monitors reply to a GET VCP FEATURE request
SET VCP FEATURE	03	Request to change the given parameter specified by the minor op-code
DISABLE VCP FEATURE	0A	Disable specific VCP feature
ENABLE VCP FEATURE	0B	Enable specific VCP feature
GET TIMING REPORT	07	Request to return the current horizontal and vertical sync frequencies to the host
TIMING REPORT	4E	Monitors reply to a GET TIMING REPORT

(VCP = Virtual Control Panel)

12.5 List of supported VESA commands

The table below shows the supported VESA commands by the OSD menu and the external DDC interfaces.

VESA command	VESA code (hex)	R/W	OSD user menu	OSD service menu	DDC supported	Mode dependent
Brightness	10	R/W	X	X	X	X
Contrast	12	R/W	X	X	X	X
Red gain	16	R/W	X	X	X	-
Green gain	18	R/W	X	X	X	-
Blue gain	1A	R/W	X	X	X	-
H position	20	R/W	X	X	X	X
H size	22	R/W	X	X	X	X
H pincushion	24	R/W	X	X	X	X

VESA command	VESA code (hex)	R/W	OSD user menu	OSD service menu	DDC supported	Mode dependent
H pincushion balance	26	R/W	X	X	X	X
V position	30	R/W	X	X	X	X
V size	32	R/W	X	X	X	X
V linearity	3A	R/W	-	X	X	-
V linearity balance	3C	R/W	-	X	X	-
H parallelogram	40	R/W	-	X	X	-
H trapezoid	42	R/W	-	X	X	-
Tilt	44	R/W	X	X	X	-
Top corner	46	R/W	X	X	X	X
Bottom corner	4A	R/W	X	X	X	X
H moire	56	R/W	X	X	X	X
V moire	58	R/W	X	X	X	X
Red bias	6C	R/W	-	X	X	-
Green bias	6E	R/W	-	X	X	-
Blue bias	70	R/W	-	X	X	-
OSD	CA	R/W	-	-	X	-
DPMS	D6	R/W	-	-	X	-
Colour Temperature (CT)	D8	R/W	X	X	X	-
H polarity	A4	R	-	-	X	-
V polarity	A6	R	-	-	X	-
Sync type	A8	R	-	-	X	-
H frequency	AC	R	X	X	X	-
V frequency	AE	R	X	X	X	-
Degauss	01	W	X	X	X	-
Settings	B0	W	-	-	X	-
VESA test tool commands:						
Set NVM address	DC	R/W	-	-	X	-
Access NVM data	DB	R/W	-	-	X	-
Current mode number	D9	R	-	-	X	-
Factory mode	EA	R/W	-	-	X	-
User defined commands:						
OSD contrast	E7	R/W	X	X	X	-
OSD horizontal position	CB	R/W	X	X	X	-
OSD vertical position	CC	R/W	X	X	X	-
V focus	E0	R/W	-	X	X	-
V gain	E1	R/W	-	X	X	-
V offset	E2	R/W	-	X	X	-
Basedrive	EB	R/W	-	-	X	-
AC blacklevel (TDA4887 only)	EC	R/W	-	X	X	-
Pedestal blanking (TDA4887 only)	ED	R/W	-	X	X	-

Note: X means supported; - means not supported;

12.6 DPMS control

Depending upon the status of the incoming sync signals the proper power management mode will be chosen according the next table:

Vsync	Hsync	Monitor state	DPMS1 output	Remarks
Present	Present	On	Low	Monitor in operating state
Present	Not present	Stand-by	Low	Video will be blanked & deflection controller in stand-by state
Not present	Present	Suspend	Low	Video will be blanked & deflection controller in stand-by state
Not present	Not present	Off	High	Video will be blanked, deflection controller in stand-by state & the SMPS is set into burst mode

12.7 Horizontal linearity capacitors

The switching characteristics of the horizontal linearity capacitors, H_lin0, H_lin1 and H_lin2, are given in the table below. (The output level of the micro-controller pins H_lin0/1/2 is given)

Horizontal frequency	H_lin0	H_lin1	H_lin2
≤ 33 kHz (also the safe setting)	Low	Low	Low
≤ 34 kHz	Low	Low	High
≤ 37 kHz	Low	High	Low
≤ 41 kHz	Low	High	High
≤ 46 kHz	High	Low	Low
≤ 53 kHz	High	Low	High
≤ 63 kHz	High	High	Low
≤ 70 kHz (= max horizontal frequency)	High	High	High

12.8 NVM related items

12.8.1 Factory pre-programmed video modes

The pre-programmed video modes are listed in the table below:

Factory mode	VESA mode	Vertical frequency	Horizontal frequency
0	640 x 480	60 Hz	31.5 kHz
1	640 x 480	72 Hz	37.9 kHz
2	640 x 480	85 Hz	43.3 kHz

Factory mode	VESA mode	Vertical frequency	Horizontal frequency
3	800 x 600	60 Hz	37.9 kHz
4	800 x 600	75 Hz	46.9 kHz
5	800 x 600	85 Hz	53.7 kHz
6	1024 x 768	60 Hz	48.4 kHz
7	1024 x 768	75 Hz	60.0 kHz
8	1024 x 768	85 Hz	68.7 kHz
9	640 x 480	75 Hz	37.5 kHz

12.8.2 NVM memory map layout

The NVM mapping layout is given in the table below and must be used to pre-program the NVM. The size of the NVM is 1024 bytes, divided into 4 banks of 256 bytes.

Sub-address (decimal)	Contents	Remarks
0 .. 39	H- and V-sync frequencies of the factory pre-defined video modes 0 to 9	<p>The horizontal and vertical frequencies of the factory pre-defined video modes are used during the mode adaptation sequence to check if the new mode is already stored into the NVM. This data must be pre-programmed into the NVM.</p> <p>The frequencies are stored in groups of 4 bytes:</p> <ul style="list-style-type: none"> • index 0: horizontal-high; • index 1: horizontal-low; • index 2: vertical-high; • index 3: vertical-low; <p>Example of the frequency coding: 31.50 kHz: 3150 (dec) = 0C4E (hex), H-high=0C; H-low=4E 120.5 Hz: 12050 (dec) = 2F12 (hex), V-high=2F; V-low=12</p> <p>Sub-address mapping:</p> <ul style="list-style-type: none"> • sub-address 0: factory mode 0; • sub-address 4: factory mode 1; • :: • sub-address 36: factory mode 9;

Sub-address (decimal)	Contents	Remarks												
40 .. 79	H- and V-sync frequencies of the user programmable video modes 0 to 9	<p>The horizontal and vertical frequencies of the user programmable video modes are used during the mode adaptation sequence to check if the new mode is already stored into the NVM.</p> <p>For the coding see: “H- and V-sync frequencies of the factory pre-defined video modes 0 to 9”.</p> <p>Sub-address mapping:</p> <ul style="list-style-type: none"> • sub-address 40: user mode 0; • sub-address 44: user mode 1; <li style="text-align: center;">:: • sub-address 76: user mode 9; 												
80 .. 89	Sync polarity for the factory pre-defined video modes 0 to 9 and user programmable video modes 0 to 9	<p>The horizontal and vertical sync polarities of the factory pre-defined and user programmable video modes are used during the mode adaptation sequence to check if the new mode is already stored into the NVM. The data belonging to the factory pre-programmed video modes must be pre-programmed into the NVM.</p> <table border="1" data-bbox="644 1137 1460 1391"> <tr> <td data-bbox="644 1137 794 1211">Bit:</td> <td data-bbox="794 1137 847 1211">7 3</td> <td data-bbox="847 1137 900 1211">6 2</td> <td data-bbox="900 1137 952 1211">5 1</td> <td data-bbox="952 1137 1005 1211">4 0</td> <td data-bbox="1005 1137 1460 1211">Even modes (0,2,4..) Odd modes (1,3,5..)</td> </tr> <tr> <td data-bbox="644 1211 794 1391">value</td> <td data-bbox="794 1211 847 1391">0 0 0 0 0</td> <td data-bbox="847 1211 900 1391">0 0 0 0 1</td> <td data-bbox="900 1211 952 1391">0 0 1 1 x</td> <td data-bbox="952 1211 1005 1391">0 1 0 1 x</td> <td data-bbox="1005 1211 1460 1391">H & V negative polarity H negative; V positive H positive; V negative H & V positive polarity H & V polarity is don't care</td> </tr> </table> <p>Sub-address mapping:</p> <ul style="list-style-type: none"> • sub-address 80: factory mode 0 & 1; <li style="text-align: center;">:: • sub-address 84: factory mode 8 & 9; • sub-address 85: user mode 0 & 1; <li style="text-align: center;">:: • sub-address 89: user mode 8 & 9; 	Bit:	7 3	6 2	5 1	4 0	Even modes (0,2,4..) Odd modes (1,3,5..)	value	0 0 0 0 0	0 0 0 0 1	0 0 1 1 x	0 1 0 1 x	H & V negative polarity H negative; V positive H positive; V negative H & V positive polarity H & V polarity is don't care
Bit:	7 3	6 2	5 1	4 0	Even modes (0,2,4..) Odd modes (1,3,5..)									
value	0 0 0 0 0	0 0 0 0 1	0 0 1 1 x	0 1 0 1 x	H & V negative polarity H negative; V positive H positive; V negative H & V positive polarity H & V polarity is don't care									
90	spare	To be filled with 0												
91 .. 210	Mode dependent settings for the factory pre-defined video modes 0 to 9	<p>The following 12 controls are stored for each video mode:</p> <ul style="list-style-type: none"> • index 0: H position; (max value: 255) • index 1: H size; (max value: 255) • index 2: V position; (max value: 127) • index 3: V size; (max value: 127) • index 4: H moire; (max value: 63) • index 5: V moire; (max value: 63) • index 6: H pincushion (max value: 63) • index 7: H pincushion balance (max value: 63) 												

Sub-address (decimal)	Contents	Remarks
		<ul style="list-style-type: none"> index 8: H top corner (max value: 63) index 9: H bottom corner (max: value: 63) index 10: Brightness (max value: 63) index 11: Contrast (max value: 63) <p>Sub-address mapping:</p> <ul style="list-style-type: none"> sub-address 91: factory mode 0; sub-address 103: factory mode 1; :: sub-address 199: factory mode 9;
211 .. 220	spare	To be filled with 0
221 .. 340	Mode dependent settings for the user programmable video modes 0 to 9	<p>The 12 controls are stored for each video mode. For the coding see: “Mode dependent settings for the factory pre-defined video modes 0 to 9”.</p> <p>Sub-address mapping:</p> <ul style="list-style-type: none"> sub-address 221: user mode 0; sub-address 233: user mode 1; :: sub-address 329: user mode 9;
341 .. 351	spare	To be filled with 0
352 .. 362	Mode independent settings	<p>The following 11 controls are stored independent for each video mode:</p> <ul style="list-style-type: none"> index 0: H trapezium; (max value: 63) index 1: H parallelogram; (max value: 63) index 2: tilt; (max value: 255) index 3: V linearity; (max value: 15) index 4: V linearity balance; (max value: 15) index 5: V focus; (max value: 15) index 6: V gain; (max value: 63) index 7: V offset; (max value: 15) index 8: OSD contrast; (max value: 15) index 9: OSD H position; (max value: 100) index 10: OSD V position; (max value: 100)
363 .. 365	R-/G-/B-gain settings for the user CT settings	sub-address 363, 364 & 365: R-/G-/B-gain for user setting (max value for gain: 63)
366 .. 368	spare	To be filled with 0
369	Current mode number	<p>The mode number of the current video mode:</p> <ul style="list-style-type: none"> 0 to 9 for factory mode 0 to 9; 10 to 19 for user mode 0 to 9;
370	New user mode index	This index is used to store a new detected user video mode. The index wraps around from 9 to 0. This means that a new one will overwrite the oldest mode, in case the 10 user modes are used.
371	Colour temperature index	Index to select the CT setting:

Sub-address (decimal)	Contents	Remarks
		<ul style="list-style-type: none"> value 0: 9300K; value 1: 6500K; value 2: 5500K; value 3: user setting;
372	spare	To be filled with 0
373	Serial number	The monitors serial number, value from 0 to 255
374 .. 493	Mode dependent settings for the factory pre-defined video modes 0 to 9 which are used during factory recall	<p>Contains the 12 mode dependent controls which are used during a factory recall from the OSD menu. This data must be pre-programmed.</p> <p>Sub-address mapping:</p> <ul style="list-style-type: none"> sub-address 374: factory mode 0; sub-address 386: factory mode 1; :: sub-address 482: factory mode 9;
494 .. 508	spare	To be filled with 0
509 .. 519	Mode independent settings which are used during factory recall	The 11 controls which are stored independent for each video mode, see also "Mode independent settings"
520 .. 523	spare	To be filled with 0
524 .. 532	R-/G-/B-gain for pre-defined CT settings	<ul style="list-style-type: none"> sub-address 524, 525 & 526: R-/G-/B-gain for 9300K sub-address 527, 528 & 529: R-/G-/B-gain for 6500K sub-address 530, 531 & 532: R-/G-/B-gain for 5500K (max value for gain: 63)
533 .. 535	R-/G-/B-bias settings	<p>The bias settings are independent from the selected CT.</p> <ul style="list-style-type: none"> sub-address 533: R-bias sub-address 534: G-bias sub-address 535: B-bias <p>(max value for bias: 255)</p>
536 .. 547	Mode dependent settings which are used when a new user mode is detected	Contains the 12 mode dependent controls which are used when a new user mode is detected. This data must be pre-programmed.
548, 549	Spare	To be filled with 0
550	Specific settings for the TDA4887	<p>Contains the specific TDA4887 controls:</p> <ul style="list-style-type: none"> Black level for AC coupling, bits 2, 1, and 0; Depth of pedestal blanking, bits 5 and 4;
551 .. 639	spare	To be filled with 0
640 .. 767	EDID version-1 data	128 bytes of EDID, version 1, DDC data, the contents must be pre-programmed
768 .. 1023	EDID version-2 data	<p>256 bytes of EDID, version 2, DDC data, the contents must be pre-programmed.</p> <p>Note: EDIDV2 is not supported by the current software version.</p>

13. WINDOWS I²C-CONTROL SOFTWARE FOR MONITOR IC'S

Philips developed a simple bi-directional 2-wire bus for efficient inter-IC control. This bus is called the Inter IC or I²C-bus. All the IC's equipped with this feature incorporate an on-chip interface, which allows them to communicate with each other via the I²C-bus.

Here are some features of the I²C -bus:

- Only two bus lines are required; a serial data line (SDA) and a serial clock line (SCL)
- Each device connected to the bus is software addressable by a unique (Device) address
- Serial, 8-bit oriented, bi-directional data transfers can be made at up to 100 kbits/s in the standard mode or up to 400 kbits/s in the fast mode
- The number of IC's that can be connected to the same bus is limited only by a maximum bus capacitance of 400pF

In most applications the I²C-bus control is performed by a micro-controller. To be able to control all IC's, also those that are not included within a (complete) system, the I²C-control software was developed. The Monitor I²C-Control software is used to control all monitor IC's in co-operation with one of the hardware interface boards mentioned below.

13.1 Hard- and Software Requirements.

To be able to run the program you need:

1. An IBM-PC or compatible personal computer;
2. Windows-3.11, Windows-95, Windows-98 or Windows-NT operating system;
3. At least 512 Kbytes of RAM memory;
4. A CENTRONICS to I²C-bus interface board:
 - Multi-Master;
 - Hardwareless;
 - Single-Master;
 - Dual Single Master Port 1 (Windows NT only);
 - Dual Single Master Port 2 (Windows NT only).

13.2 Monitor IC's that can be controlled

The version 3.60.xx can control the following IC's:

1. Deflection Controllers TDA48xx;
2. Video Controllers TDA488x;
3. Octuple 8-bit DA controller TDA8447;
4. Autosize IC TDA4821.

13.3 I2C control modes

From version 3.60.00 on the I2C software can operate in two control modes:

- 1) Direct-I2C mode using the internal I2C-bus of the monitor,
- 2) DDC2Bi mode using the external I2C-bus of the microprocessor.

Note: In the ECO-monitor the base-drive current is modulated by the horizontal size information when you regulate Hsize via the OSD-menu or via the PC I2C-software in DDC2Bi mode. Using the PC I2C-software in Direct-I2C mode this base-drive current is not modulated, which may cause a high power dissipation in the horizontal deflection transistor. Using the PC I2C-software for controlling the Hsize we advise to use the DDC2Bi mode only.

To use Direct-I2c mode connect I2C cable to the lower connector on the mainboard (on the solder side of the PCB), to use DDC2Bi mode connect the I2C cable to the upper connector on the mainboard (on the component side of the PCB).

See **AN00032** *User Manual of the Monitor I2C-Control Software V3.50.xx* for more detailed information. This application note can be found in "c:\i2c\common\mon350xx.pdf" after installation of the software.

14. ACKNOWLEDGEMENTS & REFERENCES

14.1 Application notes

1. **AN00042** *Failure Mechanisms of the Line Output Transistor*
2. **AN00040** *Vertical booster TDA4863J/TDA4863AJ*
3. **AN00032** *User Manual of the Monitor I2C-Control Software V3.50.xx*
4. **AN00047** *75W SMPS with TEA1507*
5. **AN97072** *Bus_C Controlled Autosync Deflection Controller TDA4853/54*
6. **ETV/AN97002** *Low power and low cost horizontal drive circuits with U15 core*
7. **ETV/AN97001** *Horizontal and Vertical Dynamic Focus Circuit*
8. **AN96052** *B+Converter Topologies for Horizontal Deflection and EHT with TDA4855/58*
9. **AN00038** *EMC of Monitors*

14.2 Datasheets

1. **TDA4856** *I²C-bus autosync deflection controller for PC monitors, 1998 Oct 02*
2. **TDA4863** *Vertical deflection booster, 1998 Dec 17*
3. **TDA4887PS** *160 MHz bus controlled monitor video pre-amplifier, 1999 Nov 19*
4. **PCF8598** *I²C controlled EEPROM*

APPENDIX 1 TDA4856 HORIZONTAL FREQUENCY RANGE

The horizontal frequency range of the TDA4856 is determined by the value of two resistors and one capacitor. The value of resistors R295 and R296 is determined by the frequency limits of the application. The capacitor C288 (horizontal oscillator capacitor connected to pin 29 HCAP) must be 10nF for optimum jitter performance. The value of this capacitor should not be changed.

Given a specified frequency range (and C288 = 10nF) the values of the resistors R295 and R296 can be calculated with the following formulas:

Notes:

1. the minimum and maximum frequencies in the formulas should be inserted in 'kHz'. Tolerance taken in account is 7% for f_{max} and 9% for f_{min} when 2% tolerance on the oscillator capacitor and 1% resistors are used.
2. R'296 does not exist; this R'296 is only needed for the calculation.

$$R_{295} = \frac{78}{f_{min} + 0.0012 \times f_{min}^2} [k\Omega]$$

$$R'_{296} = \frac{78}{f_{max} + 0.0012 \times f_{max}^2} [k\Omega]$$

$$R_{296} = \frac{R_{295} \times R'_{296}}{R_{295} - R'_{296}} \times 0.8 [k\Omega]$$

Equation 1 Calculation of horizontal PLL resistors R308 and R309

For a guaranteed frequency range of 30 to 70kHz the resistor values are:

$$R_{295} = 2.74k\Omega$$

$$R_{296} = 1.17k\Omega \text{ (1.21 k}\Omega \text{ rounded to match E48 range)}$$